

ICOM

**SERVICE
MANUAL**

Clip D33, D34 (PL unit) - (top cover, Pull PA Unit)

For out of Band TX

HF ALL BAND TRANSCEIVER

IC-735

Icom Inc.

TABLE OF CONTENTS

SECTION 1	SPECIFICATIONS	1-1
1-1	GENERAL	1-1
1-2	TRANSMITTER	1-1
1-3	RECEIVER	1-1
SECTION 2	INSIDE VIEWS	2-1~3
2-1	MAIN UNIT	2-1
2-2	PL UNIT	2-2
2-3	PA UNIT (POWER AMPLIFIER AND FILTER)	2-3
SECTION 3	DISASSEMBLY AND ASSEMBLY DIAGRAMS	3-1~6
3-1	FRONT PANEL DISASSEMBLY	3-1
3-2	TOP COVER, BOTTOM COVER, PA DISASSEMBLY	3-2
3-3	FRONT SUB-CHASSIS CONNECTOR ASSEMBLY	3-3
3-4	MAIN UNIT CONNECTOR ASSEMBLY	3-4
3-5	PL UNIT CONNECTOR ASSEMBLY	3-5
3-6	PA UNIT CONNECTOR ASSEMBLY	3-6
SECTION 4	BLOCK DIAGRAM	4-1
SECTION 5	CIRCUIT DESCRIPTION	5-1~23
	MAIN UNIT	5-1
	PL UNIT	5-6
	FRONT UNIT	5-16
	PA UNIT	5-17
	THEORY OF MATRIX FUNCTION	5-19
SECTION 6	VOLTAGE/CIRCUIT DIAGRAMS	6-1~6
6-1	FRONT UNIT AND WIRING DIAGRAM	6-1
6-2	MAIN UNIT	6-2
6-3	PL UNIT	6-3
6-4	PA UNIT (POWER AMPLIFIER)	6-4
6-5	PA UNIT (FILTER)	6-5
6-6	FRONT UNIT DIMMER CIRCUIT	6-6
6-7	SENSOR UNIT	6-6
SECTION 7	MAINTENANCE AND ADJUSTMENT	7-1~12
7-1	PREPARATION BEFORE SERVICING	7-1
7-2	GENERAL ADJUSTMENT	7-2
7-3	PL UNIT ADJUSTMENT	7-3
7-4	TRANSMITTER ADJUSTMENT	7-5
7-5	RECEIVER ADJUSTMENT	7-9
7-6	ADJUSTMENT LOCATIONS	7-10
7-7	LITHIUM BATTERY REPLACEMENT	7-12
7-8	FUSE REPLACEMENT	7-12
SECTION 8	BOARD LAYOUTS	8-1~6
8-1	FRONT UNIT	8-1
8-2	MAIN UNIT	8-2
8-3	PL UNIT	8-3
8-4	PA UNIT (POWER AMPLIFIER)	8-4
8-5	PA UNIT (FILTER)	8-5
8-6	SENSOR UNIT	8-6
SECTION 9	PARTS LIST	9-1~23

SCHEMATIC DIAGRAM Attached at the end of this service manual

SECTION 1 SPECIFICATIONS

1 - 1 GENERAL

Number of semiconductors:	
Transistors	124
FETs	18
Diodes	258
ICs (Includes CPU)	42
Frequency coverage:	
Ham Bands	1.8MHz ~ 2.0MHz
	3.4MHz ~ 4.1MHz
	6.9MHz ~ 7.5MHz
	9.9MHz ~ 10.5MHz
	13.9MHz ~ 14.5MHz
	17.9MHz ~ 18.5MHz
	20.9MHz ~ 21.5MHz
	24.4MHz ~ 25.1MHz
	27.9MHz ~ 30.0MHz

General Coverage
(Receive Only) 0.1MHz ~ 30.0MHz

Usable temperature range:
-10°C ~ +60°C (+14°F ~ +140°F)

Frequency control:
CPU based 10Hz step digital PLL synthesizer.
Independent Transmit/Receive frequency available on the same band.

Frequency readout:
6 digit 100Hz illuminated LCD

Frequency stability:
Less than ±200Hz from 1 minute after switch ON to 60 minutes
Less than ±30Hz after 1 hour at 25°C
Less than ±500Hz in the range of 0°C ~ +50°C

Power supply requirements:
13.8V DC ±15% (negative ground)
Current drain 20A maximum at 200W input
AC power supply is available for AC operation.

Current drain (at 13.8V DC):

Transmitting	
At 200 watts input	Approx. 20.A
Receiving	
At maximum audio output	Approx. 1.5A
Squelched	Approx. 1.2A

Antenna impedance:
50 ohms unbalanced

Weight:
5.05kg (Includes options FL-32, IC-EX243, and UT-30)

Dimensions:
94(107)mm(H)×241(244)mm(W)×239(272)mm(D)
() Dimensions include projections

1 - 2 TRANSMITTER

RF power:

SSB (A3/J3E)	200 watts PEP input
CW (A1/A1A)	200 watts input
AM (A3/A3E)	40 watts output
FM (F3/F3E)	200 watts input

Continuously adjustable output power from 10 watts to maximum.

Emission modes:

A3J (J3E) SSB (Upper and Lower Sideband)
A1 (A1A) CW
A3 (A3E) AM
F3 (F3E) FM

Harmonic output:

More than 40dB below peak power output

Spurious output:

More than 50dB below peak power output

Carrier suppression:

More than 40dB below peak power output

Unwanted sideband:

More than 50dB down at 1000Hz AF input

Microphone:

600 ohm electret condenser microphone with Push-To-Talk switch and scanning buttons

1 - 3 RECEIVER

Receive system:

Triple conversion superheterodyne with continuous bandwidth control

Receive modes:

A3J (J3E) SSB (Upper and Lower Sideband)
A1 (A1A) CW
A3 (A3E) AM
F3 (F3E) FM

Intermediate frequencies:

1st:	SSB, AM, FM	70.4515MHz
	CW	70.4506MHz
2nd:	SSB, AM, FM	9.0115MHz
	CW	9.0106MHz
3rd:	SSB, CW, AM, FM	455kHz

Sensitivity:

SSB, CW	
0.1 ~ 1.6MHz	Less than 1.0µV for 10dB S/N
0.6 ~ 30MHz	Less than 0.15µV for 10dB S/N
AM (When selecting NARROW FILTER)	
0.1 ~ 1.6MHz	Less than 6µV for 10dB S/N
1.6 ~ 30MHz	Less than 1µV for 10dB S/N
FM	
1.6 ~ 30MHz	Less than 0.5µV for 12dB SINAD

Squelch sensitivity:

FM 0.3µV

Selectivity:

SSB, CW	2.3kHz @ -6dB, 4.0kHz @ -60dB
AM	6.0kHz @ -6dB, 18kHz @ -50dB
FM	15kHz @ -6dB, 30kHz @ -60dB

Spurious and image response rejection:

More than 80dB

Notch filter attenuation:

More than 30dB

Audio output:

More than 3 watts @ 10% distortion with 8 ohm load

Audio output impedance:

8 ohms

SECTION 2 INSIDE VIEWS

2 - 1 MAIN UNIT

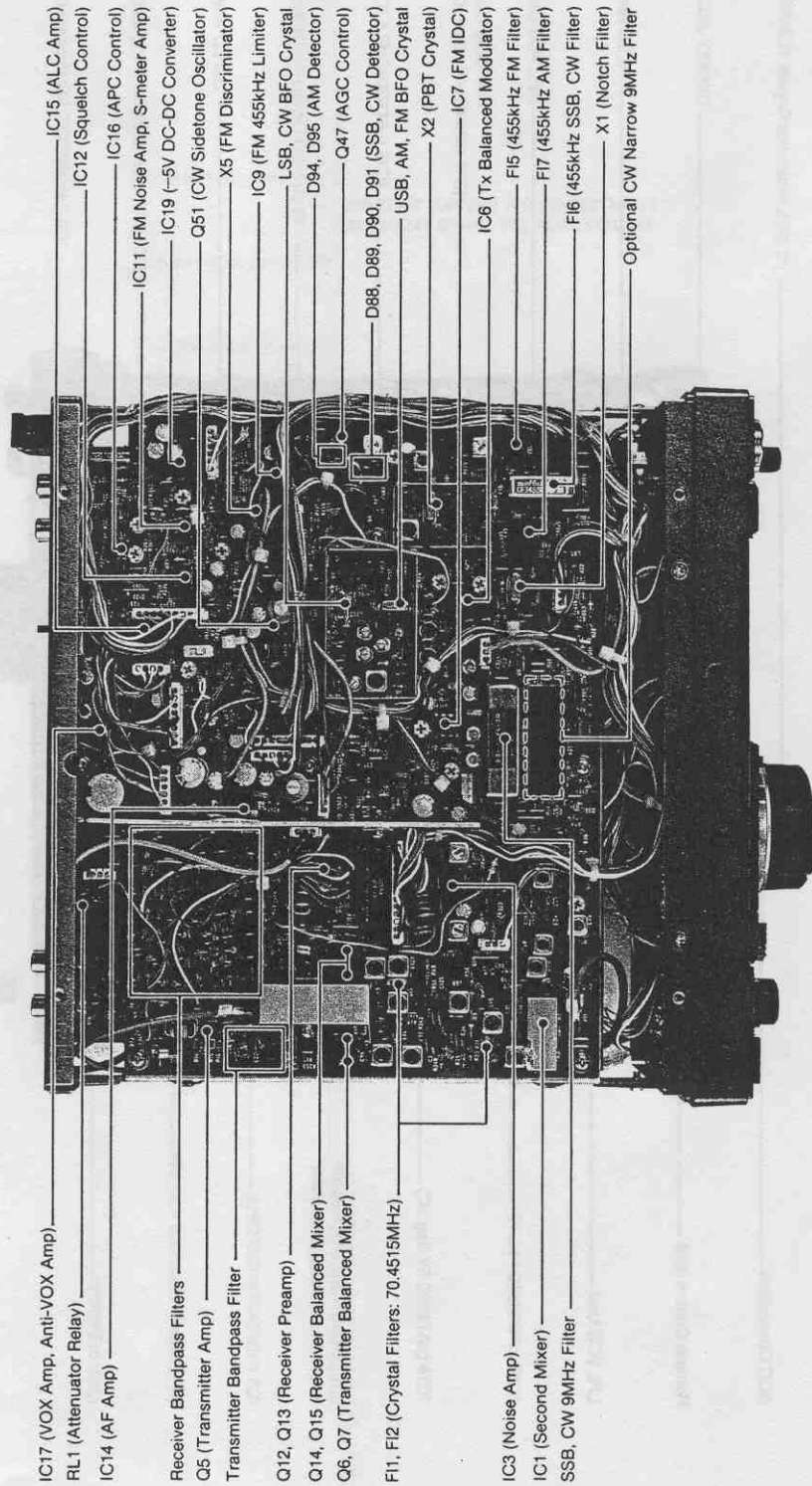

2-2 PL UNIT

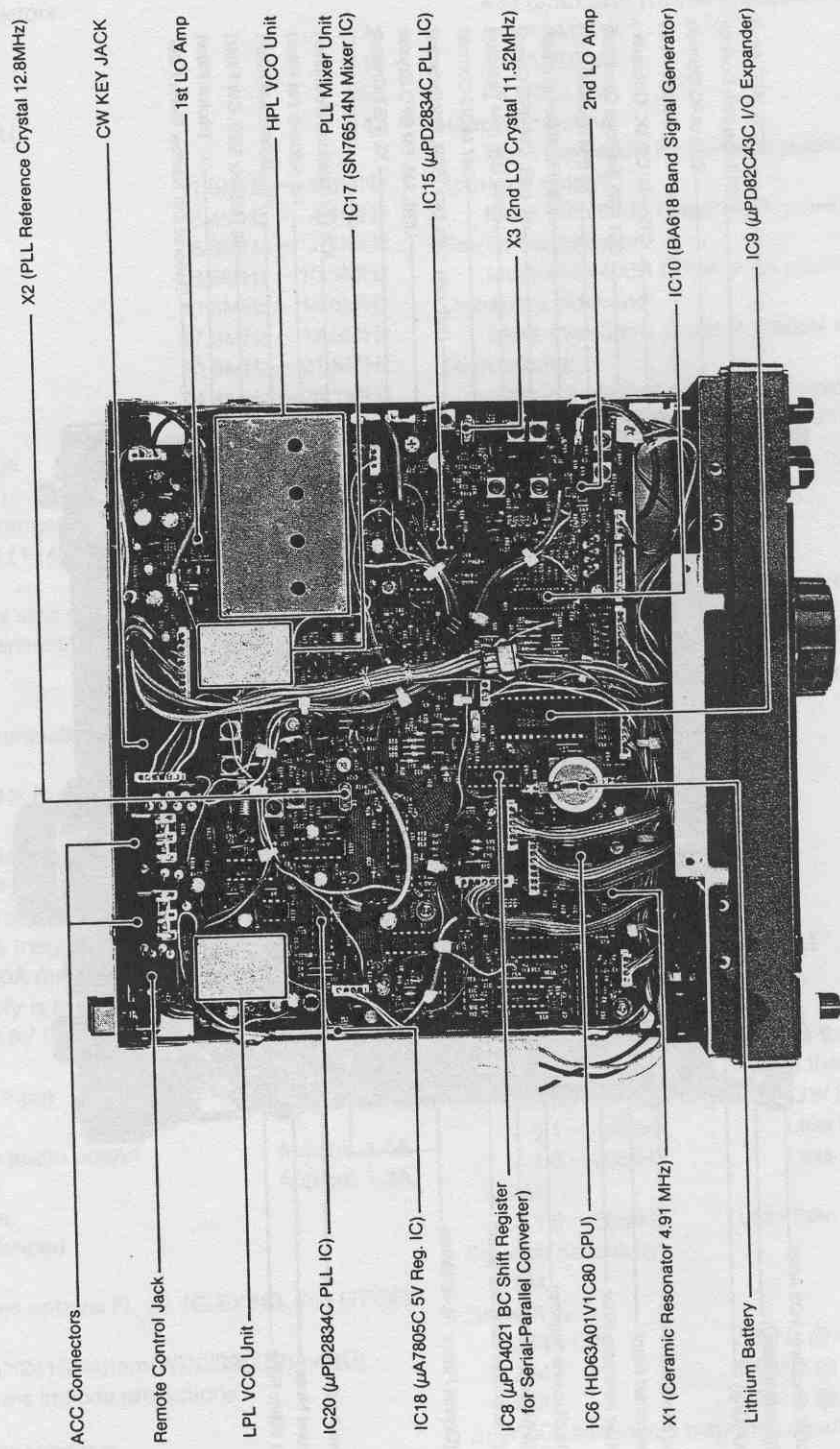

2 - 3 PA UNIT (POWER AMPLIFIER AND FILTER)

L30 (LR-53) COILS FOR L31 (LR-54) 8~15MHz RANGE

J5 (AT-700) RECEIVER ANTENNA OUTPUT JACK

J4 (FM-MDR M1) ANTENNA (ANT) CONNECTOR

P1 TO J14 MAIN UNIT

L32 (LR-157) COILS FOR L33 (LR-158)
15~22MHz RANGE

L34 (LA-196) COILS FOR L35 (LR-197)
22~30MHz RANGE

L28 (L4-141) COILS FOR L29 (L4-141)
4~8MHz RANGE

L26 (LR-138) COILS FOR L27 (LR-139)
2~4MHz RANGE

L24 (LR-136) COILS FOR L25 (LR-137)
0.1~2MHz RANGE

OPTIONAL IC-EX243 ELECTRONIC
KEYER UNIT

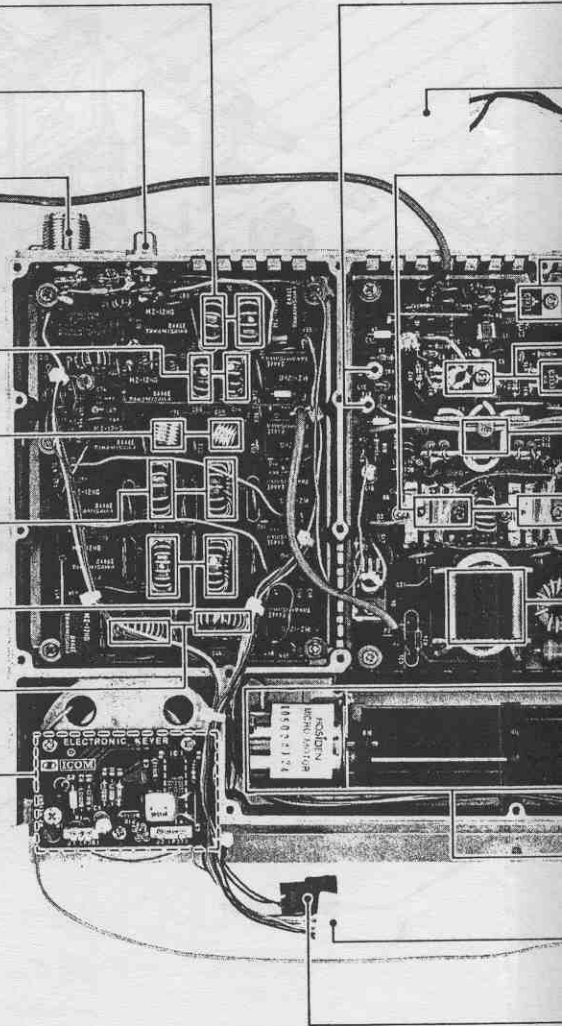

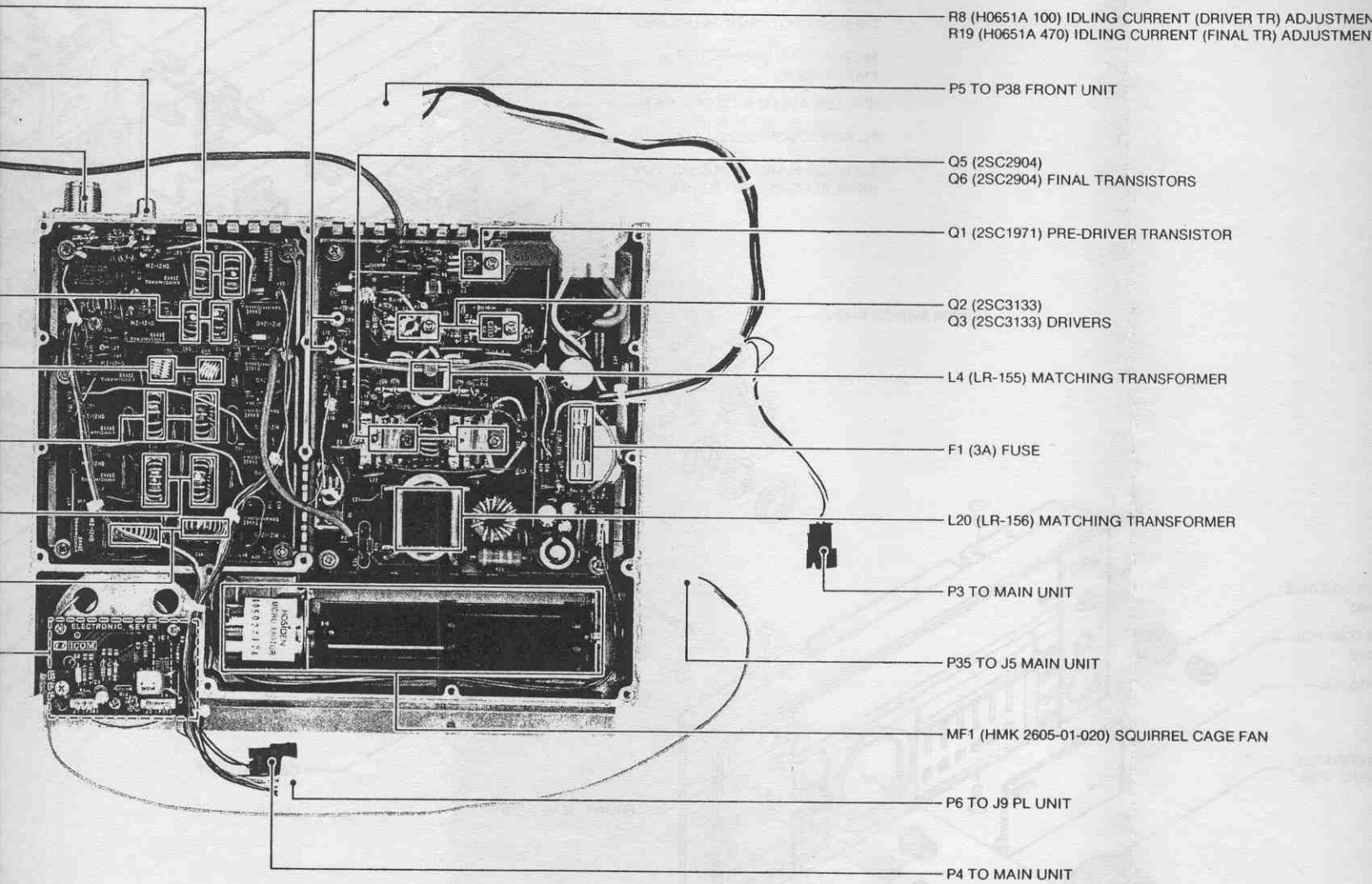

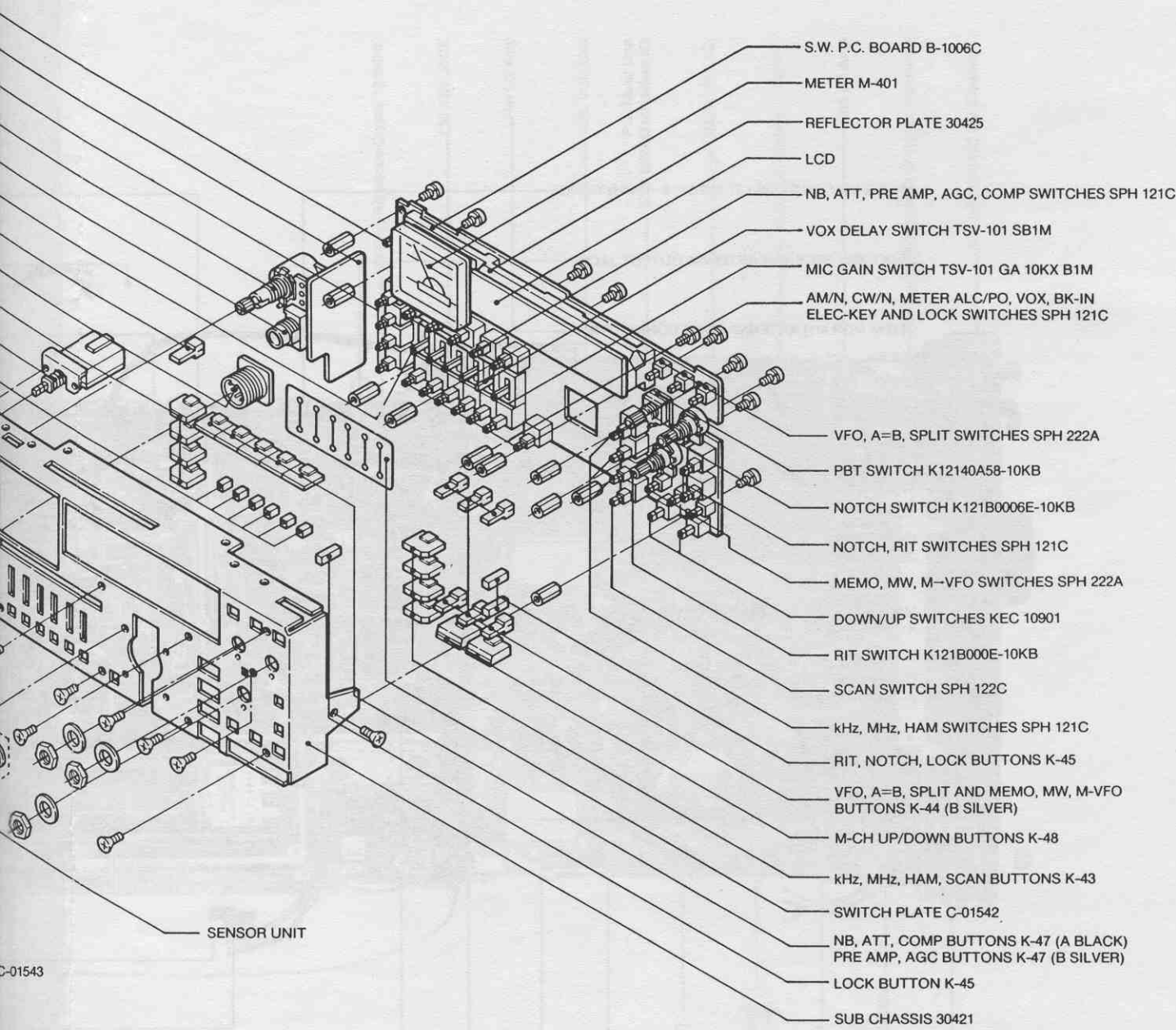

C-01543

C-01541

CONTROL KNOBS N-88

KNOB N-87

CONTROL KNOB N-86 (MP-6)

SECTION 3 DISASSEMBLY AND ASSEMBLY DIAGRAMS

3 - 1 FRONT PANEL DISASSEMBLY

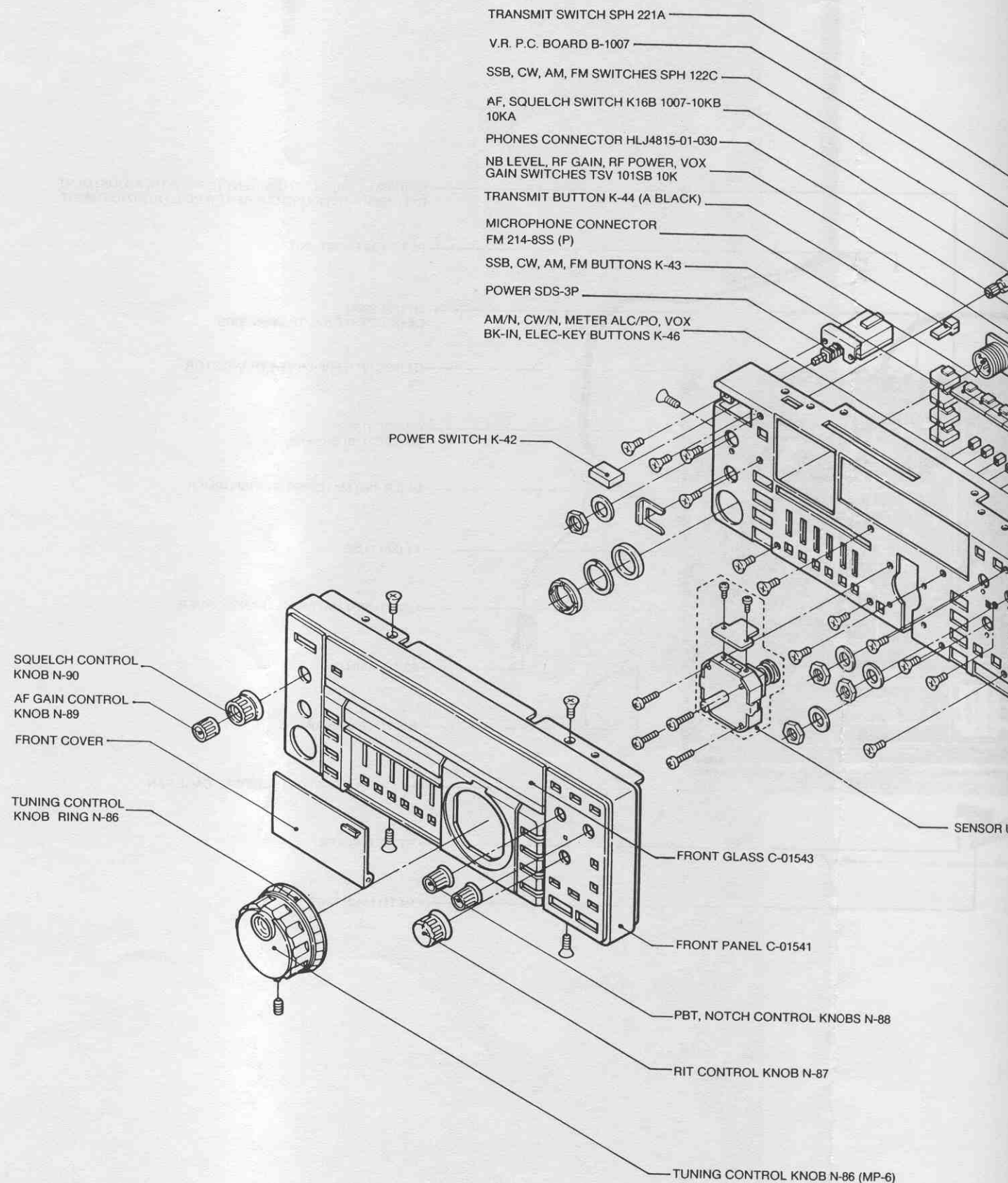

3 - 2 TOP COVER, BOTTOM COVER, PA DISASSEMBLY

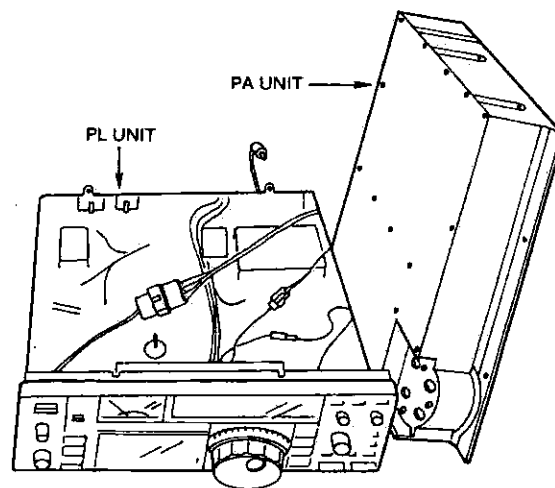
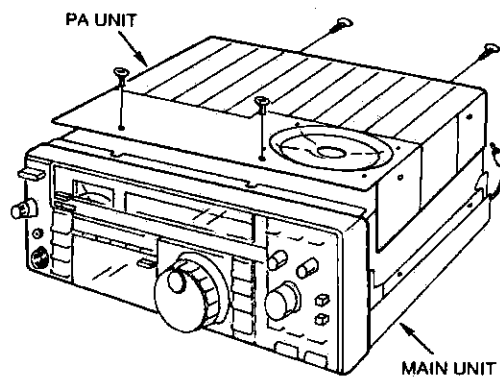
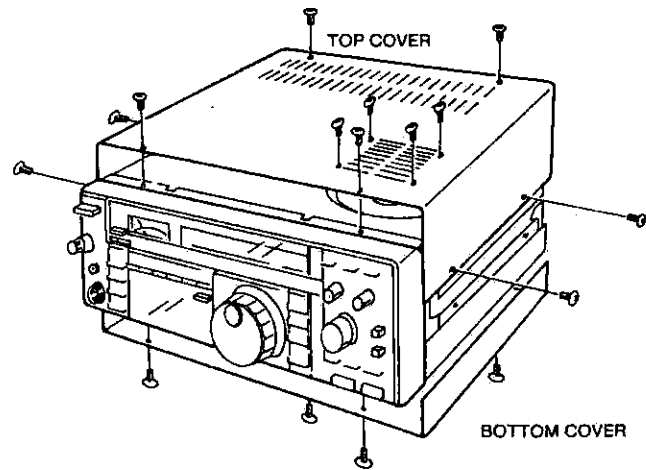

3 - 3 FRONT SUB-CHASSIS CONNECTOR ASSEMBLY

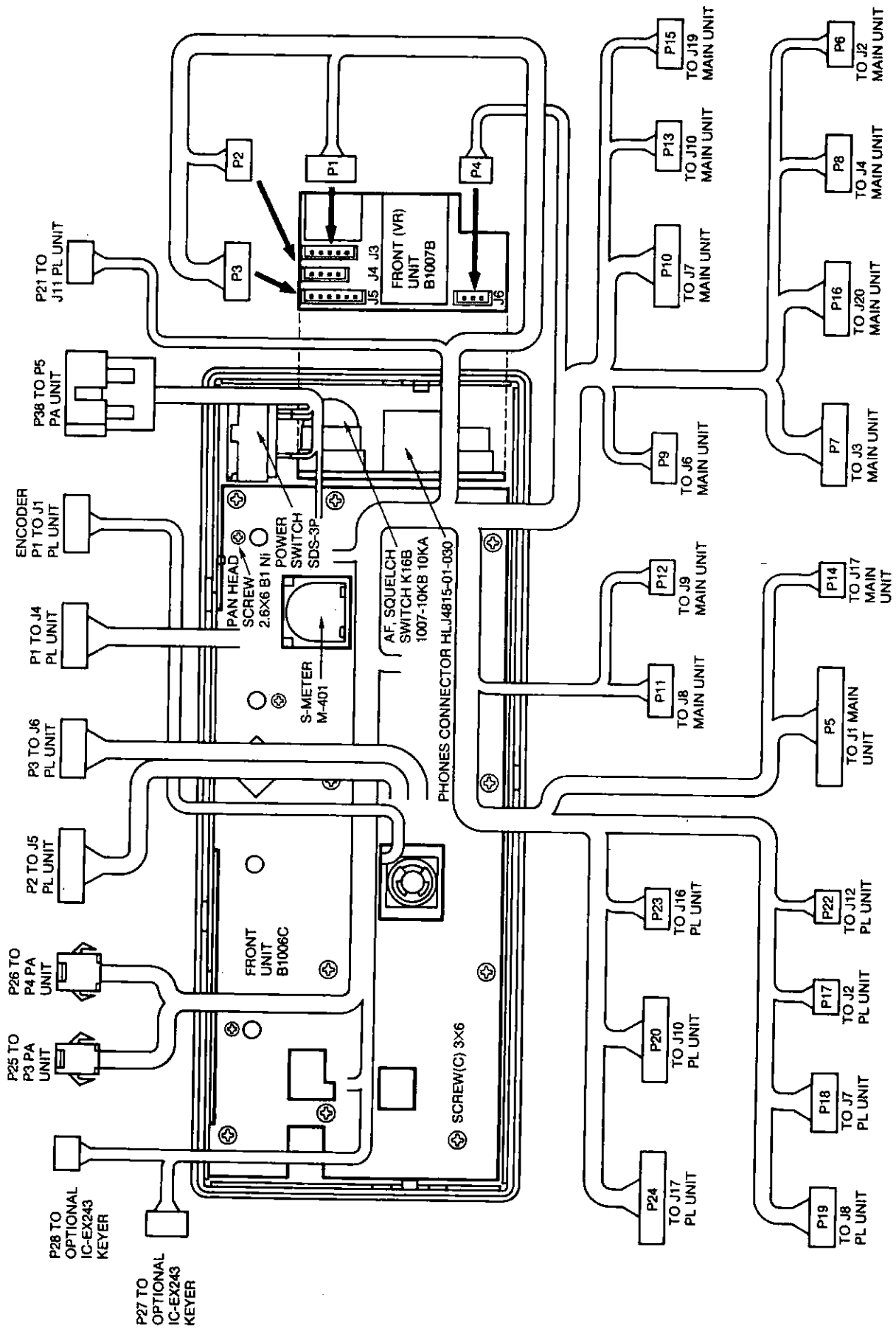

3 - 4 MAIN UNIT CONNECTOR ASSEMBLY

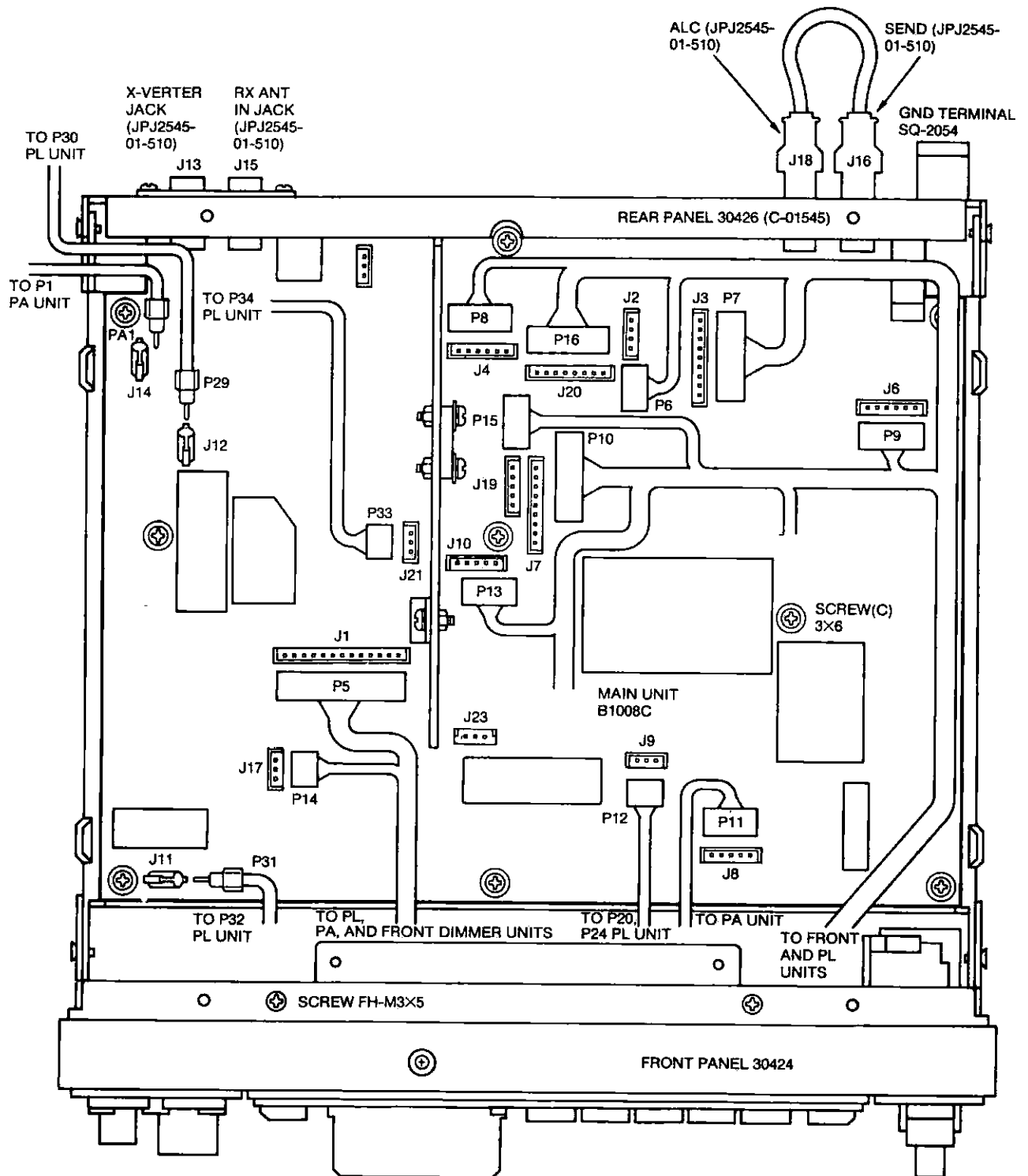

3 - 5 PL UNIT CONNECTOR ASSEMBLY

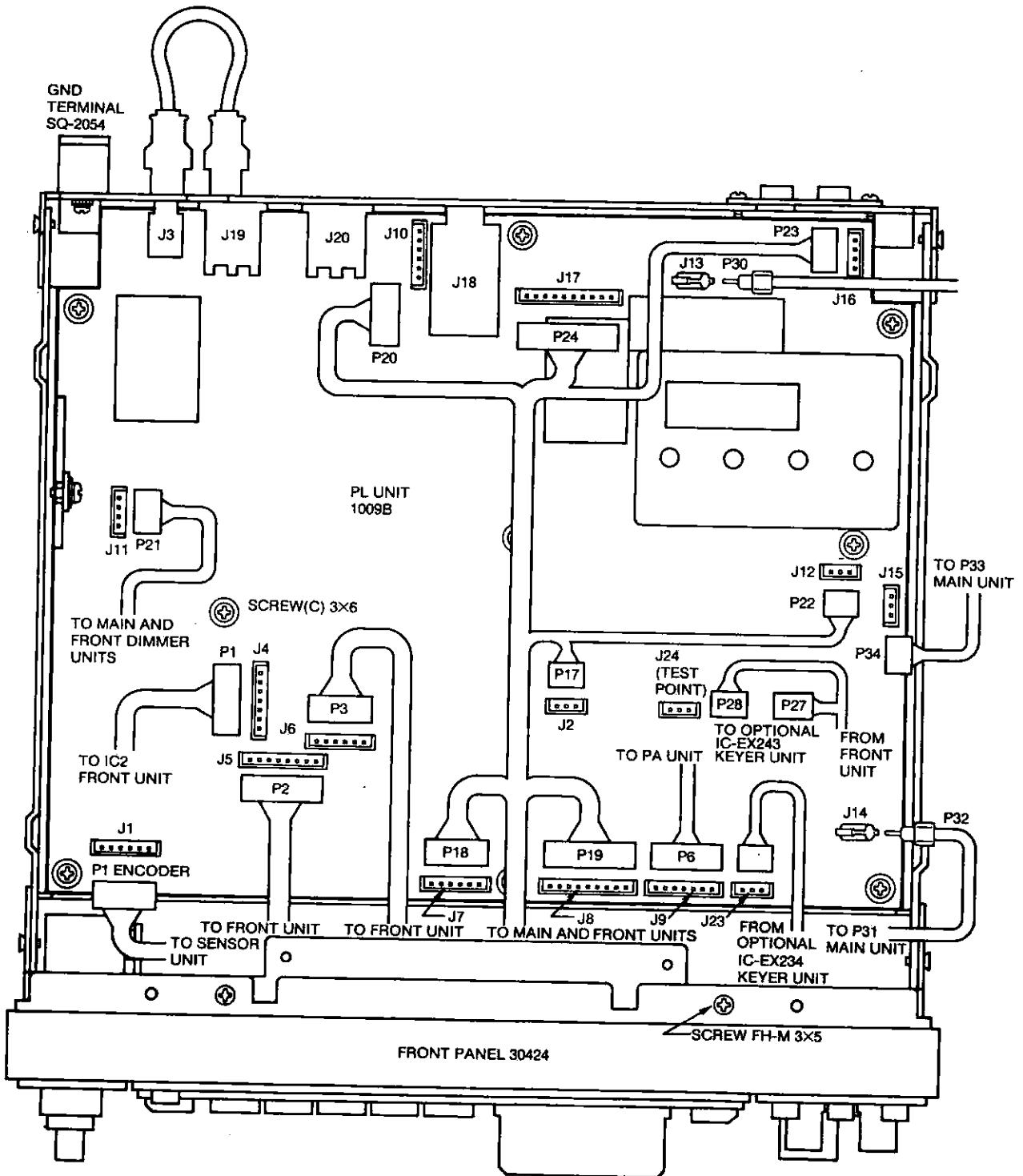

3-6 PA UNIT CONNECTOR ASSEMBLY

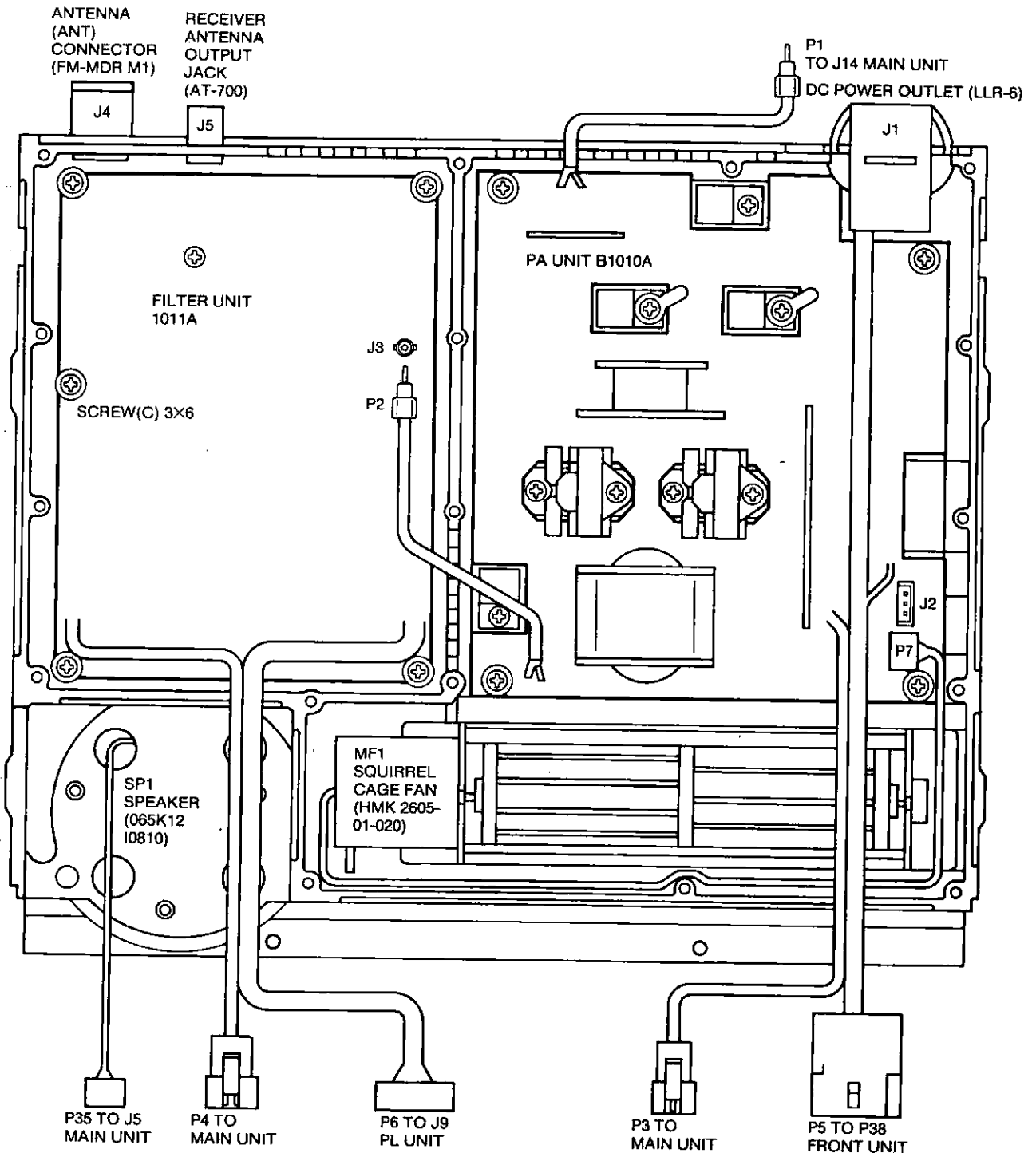

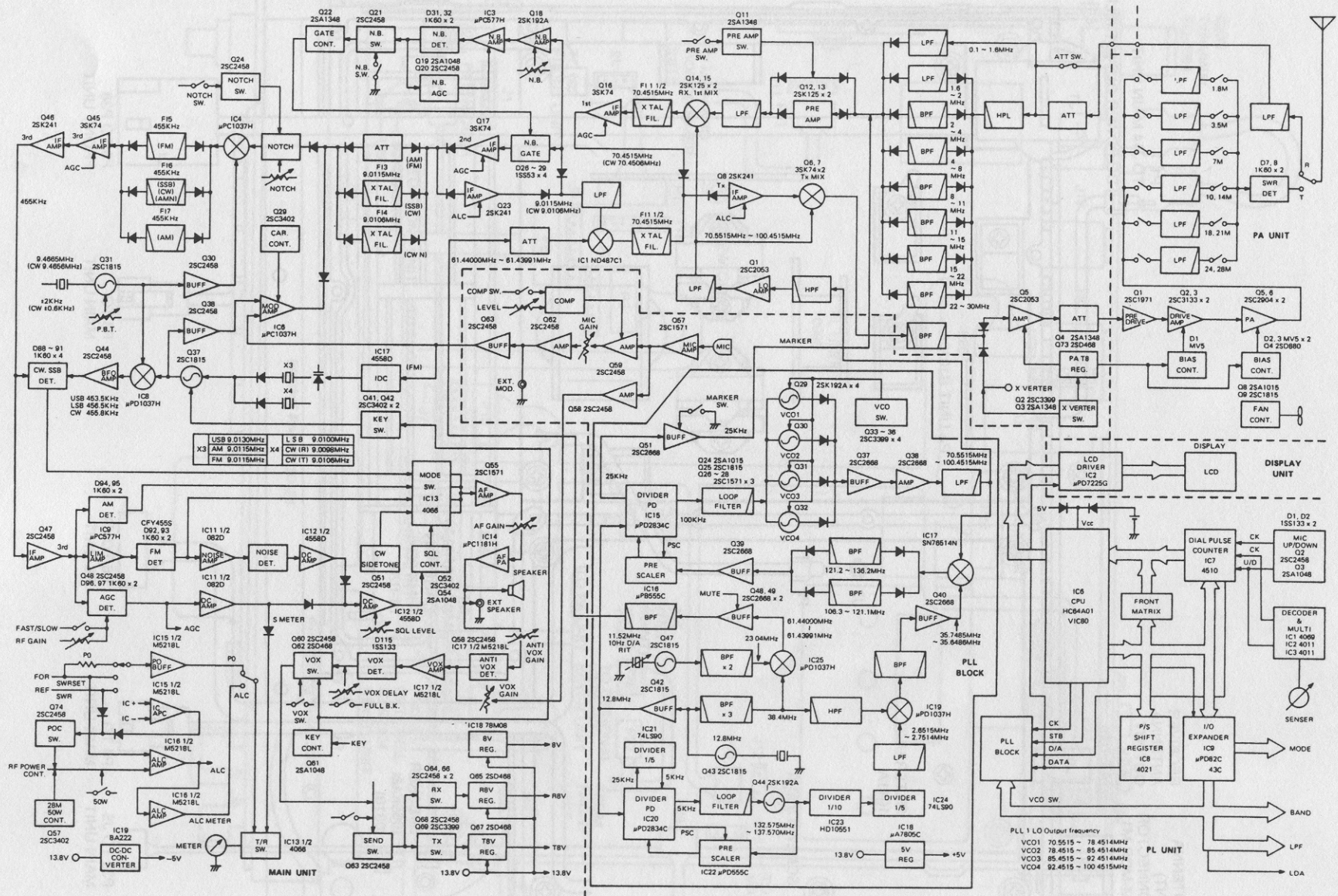

SECTION 5 CIRCUIT DESCRIPTION

■ MAIN UNIT

1. ATTENUATOR (ATT), RECEPTION BAND-PASS FILTER (BPF), AND BAND-SIGNAL DC AMPLIFIER

Receive signals enter from J15, pass through the attenuator circuit RL1 (approx. 20dB), and are fed into the various band-pass filters corresponding to the reception frequencies. As there are no non-linear components between the antenna connector and attenuator, distortion of the various components caused by strong input signal levels is effectively prevented by the attenuation circuitry.

The signals passing through the attenuator are separated into those having a frequency above 1.6MHz and those with a frequency below 1.6MHz. The signals of powerful high-frequency broadcasting stations are liable to cause diode switching distortion, but if low distortion diodes are used, signal loss in the higher bands around 28MHz will increase. This unit uses high pass filters together with low pass filters to create a diode switch-less circuit, preventing this type of distortion.

The signals between 1.6MHz and 30MHz are separated by a large series of band-pass filters located at 5MHz intervals. These band-pass filters are based upon ICOM's exclusive high frequency band-pass filters with improved band separation characteristics and a reduction in size by about 1/2. The bias voltage of the input/output diode switches of these band-pass filters is designed to be high for signal input and low for signal output. This allows for a band-pass filter which is resistant to multiple signals and strong input levels. The band signals input from the PL UNIT are DC amplified by IC2 (BA618), switching the various band-pass filters. R13.8V is used for the power supply of IC2, and there is complete isolation during transmission.

2. PRE-AMP AND MIC INPUT

Pre-amps Q12 and Q13 use the high I_{BSS} 2SK125 for amplification by approximately 10dB. They are connected parallel to one another for better matching and to reduce the impedance ratio with the output transformer. Q11 is a switch for either selecting pre-amplification or not.

The MARKER input is located between the RF band-pass filter and pre-amp, and uses a high frequency of 25kHz formed by division of the reference frequency of the PLL.

3. 1ST LO AMPLIFIER, TRANSMIT MIXER, AND RECEIVE MIXER

The 1ST LO output from the PL UNIT is connected to J12. Q4 amplifies this signal by approximately 26dBm after it passes through a high-pass filter. It is then injected to the transmit and receive mixers after its high frequency components are removed by a low-pass filter. L5 cancels the gate capacitance of the receive mixer, to create a match which will allow for the full benefits of the band-pass filters to be realized.

The receive mixer uses two of the same 2SK125 components as the RF amplifier to form a high level mixer with high

Interception Point characteristics. The cut-off frequency of the low-pass filter in the input section is in the vicinity of 35MHz to prevent 70 MHz IF signal interference and avoid 70MHz image frequency.

The transmit mixer uses two 3SK74 components to form a balanced mixer. The output load is trimmed by resistors for balanced output over a wide band.

4. 70MHz BAND IF AMPLIFIER AND CRYSTAL FILTER

The receive signals detected by the 70MHz band IF amplifier are amplified by approximately 15dB by the 1ST IF amplifier formed from F11 and Q16, and are then passed into the 2ND mixer. F11 is a double 70.4515MHz MCF with amplifier Q16 between the two components. This reduces any drop in sensitivity caused by filter insertion loss. Q16 provides a gain of approximately 18 to 20dB but this is reduced by 3 to 5dB due to filter loss.

The transmit signal passes through both F11 components, and is amplified by Q8 and input to the transmit mixer after the 61.44MHz component is removed. Q8 applies Automatic Level Control to the signal in order to prevent over-input distortion in the later stages.

5. 2ND MIXER

The diode mixer IC1 is used for conversion of the 70MHz band IF signal and 9MHz IF signal. A bi-directional mixer with low distortion is required here as the input/output signal directions for transmitting and receiving are different. This diode mixer is designed to provide especially good balance for DBM use, and local signals pass through a 3dB attenuator for 0dBm input.

6. NB CIRCUIT

The 9MHz band IF signal passes through the low pass filter consisting of C39, L19, and C40, and unnecessary signals such as 61.44MHz are removed by the double tuned filters L69 and L70. Part of the receive signal taken from between L69 and L70 is amplified by IC3, and detected by D31 and D32. The threshold level of Q20 provided AGC detection of 0.6V, and controls the gain of IC3 after being DC amplified by Q19. This operates as an averaging automatic gain control by choosing the correct time constant for R66, R70, and C142, allowing for easier detection of pulse-type noise. Q21 switches Q22 in response to the detected pulses. The threshold level of Q21 is approximately 0.3V higher than Q20, and reduces improper operation with AM signals. Noise blanking is turned ON/OFF by the emitter of Q21. When noise is detected and Q22 is turned ON, the bias of the balanced gate circuit formed from D26, 27, 28, and 29, is reversed, and the signal line is switched OFF. The signal remains OFF for the duration of the noise. The NB level is controlled by the source voltage of Q18, and has a variable range of over 20dB.

7. 9MHz BAND IF AMPLIFIER AND NOTCH FILTER

The receive signal which has passed through the noise gate is amplified by approximately 22dB after being stepped up by L71.

F13 (FL-30) is a SSB filter used in both the SSB and CW modes. If FL-32 is installed for CW, reception of a narrow bandwidth is possible with the NARROW SWITCH. If FL-32 is not installed, the SSB filter is used. The signal does not pass through this filter in the AM and FM modes, instead it goes through C155.

To ensure full isolation of this filter switch, the bias voltage is selected so that all lines are grounded except for the active one.

IC4 is connected to the output side of the filter with L76 between the two for matching.

X1 and D48 are series resonance notch filters which are switched ON/OFF by Q24. The notch frequency is adjusted by varying the bias voltage of varactor diode D48. The amount of attenuation provided by this notch filter is determined by the ratio of the contact point between X1 and L76 and series resonance impedance, and is stabilized in the range of 32 to 35dB.

IC4 is the 3rd mixer which converts the 9MHz band signals to 455kHz IF signals.

8. 455kHz IF AMPLIFIER

The reception which has been converted to 455kHz first passes through the filter corresponding to the proper mode. F15 is a 15kHz filter for FM, F16 is a 2.4kHz filter for SSB and CW, and F17 is a 6.0kHz filter for the AM mode. Ceramic filters are used for all of these. Q27 is ON in the narrow AM mode, to switch the signal through F16 (2.4kHz).

Q45 and Q46 provide approximately 50dB of amplification with R349 placed between them for temperature correction. This increases the degree of temperature stability.

9. PBT CIRCUIT

Local oscillation of Q31 and X2 is injected into IC4 and the BFO circuit, causing a relative shift in the frequency of the 455kHz ceramic filter. This functions as a PBT.

-5V is applied to the anode of D72 for biasing. Changing the voltage at the cathode between 0 and 8V provides a variable width for stable frequency adjustment at the center. The shift is approximately 900Hz in the CW mode, and an easy-to-use bandwidth of 1.5kHz/-6dB is obtained at the PBT center.

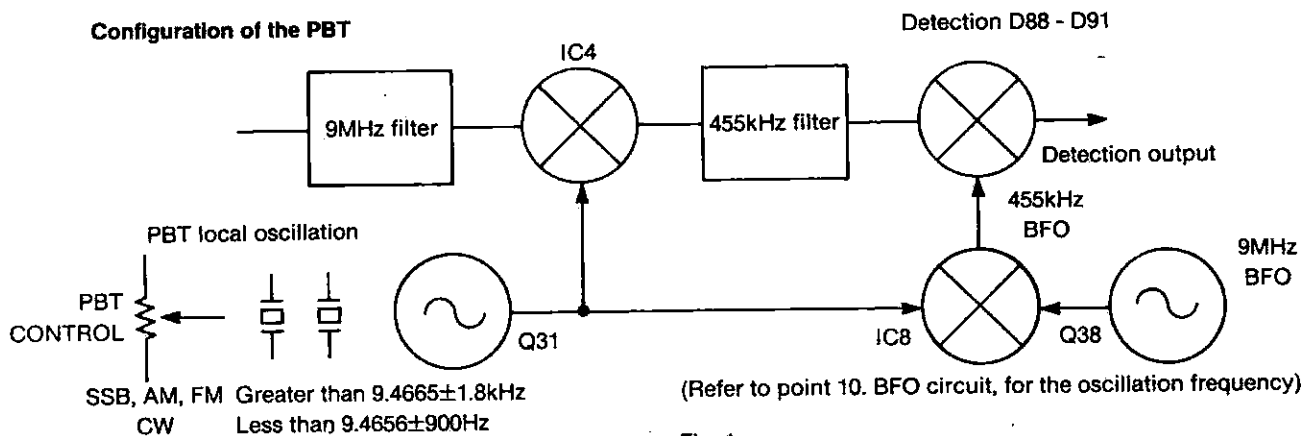
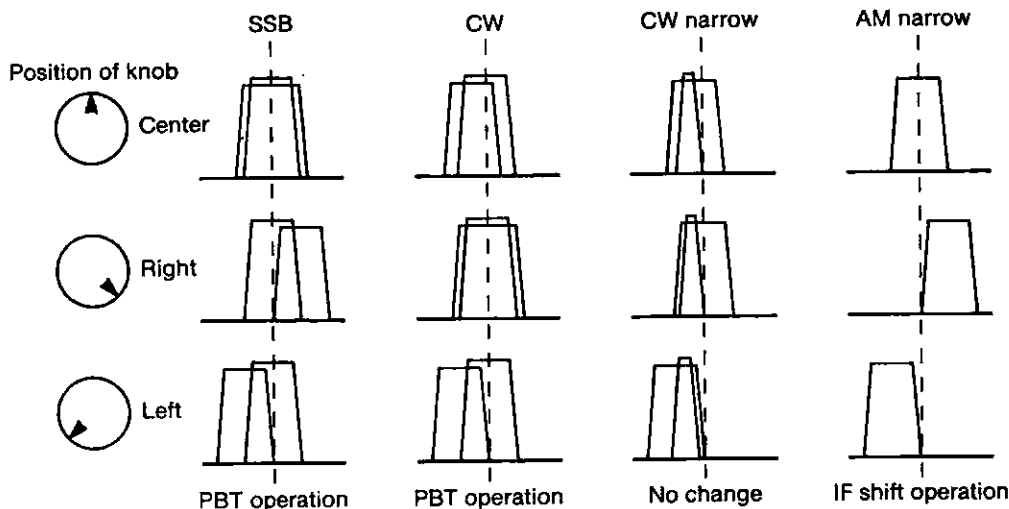

Fig. 1

PBT operation of this unit



NOTE: Passband tuning does not function when the transceiver is in the AM or FM mode since the maximum shift of the passband system is only $\pm 1.8\text{kHz}$ compared with the 6kHz AM filter and the 15kHz FM filter.

Fig. 2

10. BFO CIRCUIT

As this unit is designed for all-mode transmitting and receiving, not only SSB and CW carriers, but AM and FM transmit carriers are also generated. The CW keying circuit also provides BFO functions, and thus the space wave is negligible. The oscillation frequencies for the various modes are shown below.

Mode	Frequency	Name of crystal	Condition
USB	9.0130MHz	CR49	—
LSB	9.0100MHz	CR48	—
CW-receiving	9.0098MHz	CR48	—
CW-transmitting	9.0106MHz	CR48	Oscillation stops when key is released
AM	9.0115MHz	CR49	No oscillation during reception
FM	9.0115MHz	CR49	No oscillation during reception

With the exception of AM and FM, the various frequencies can be adjusted separately by trimmers, allowing for free adjustment of CW receiving, SSB transmitting and the receive tone.

The emitter voltage of the oscillation transistor is controlled to stop oscillation during AM and FM reception, and to perform keying for CW transmitting.

11. SSB AND CW DETECTION CIRCUIT

The BFO signal created by IC8 is amplified by Q44, and passes into the ring detection circuit formed by D88, 89, and 90. This converts CW and SSB signals to audible signals (AF). The detected analog signals are passed into the analog switch (transmitting gate), IC13.

12. FM DETECTION CIRCUIT

After the 455kHz IF signal passes through the emitter follower, it is limited by IC9 to remove AM components. X5 is a ceramic discriminator which forms an untuned FM demodulation circuit. The demodulated AF signal has its 455kHz components removed by L86 and C251, and it is fed into pin 8 of IC13 after de-emphasis by R196 and C253.

13. AM DETECTION CIRCUIT

The output of the Q47 emitter follower passes into the AM detection circuit through C260. Forward bias is applied by the diode detection circuit of D94 and D95 to eliminate distortion caused by the leading edge characteristics of diodes at low input levels. The distortion rate is typically kept at approximately 1.5% by choosing the optimum time constant for CR after detection. The AF signal feeds into pin 4 of IC13 after the extremely low band signals (less than 200Hz) are reduced by C263.

14. AGC CIRCUIT

The output of Q47 is AM and FM detected, as well as being passed into the AGC detection circuit. The AGC voltage which was constant-voltage rectified by D96 and D97 is DC amplified by Q48.

The attack of the time constant for fast AGC is determined by C267 and R207, and the delay is determined by R211. C268 and R212 are added for slow AGC. When there is RF gain control, the voltage of the AGC line is reduced by approximately -0.5V by passing it through D130. The signal passes through R213 and D131 for FM, in order to speed up the delay.

15. ALL-MODE SQUELCH CIRCUIT

The squelch circuit uses the voltage of the S-meter, but also includes operation as a noise squelch for FM.

In the SSB, CW, and AM modes, the voltage of the S-meter is passed into IC12, compared to the voltage level of the squelch variable resistor, and Q54 is controlled by Q52 which is connected to the output of pin 7. This opens and closes IC13, the analog switch IC. This analog switch switches detection output for the various modes, and sets the switching voltage of all modes to the low level for

Squelch circuit

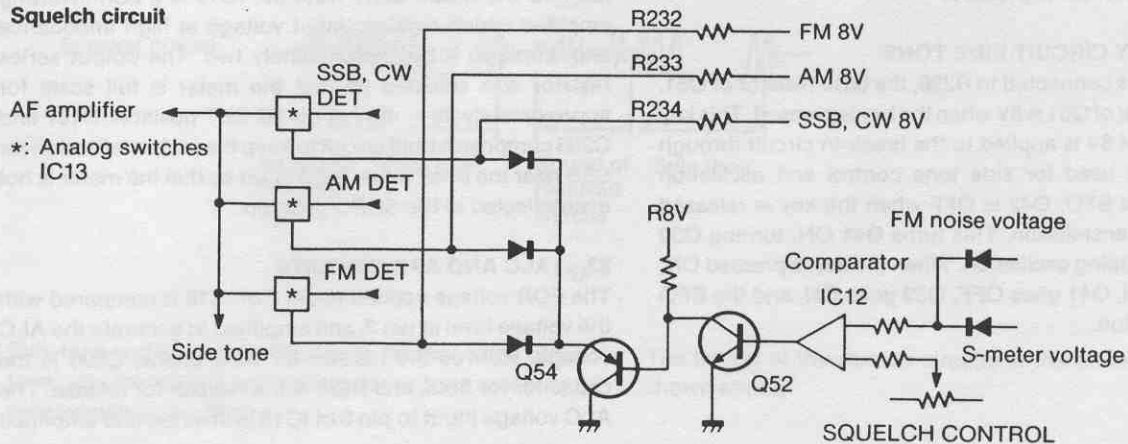

Fig. 3

squelching. Pins 2, 3, and 9 on the output side of the analog switch are all fed into the AF pre-amplifier, Q55. In the FM mode, a portion of the output signals is fed into the IC11 filter amplifier, and noise rectified by D102. The noise voltage is inverted and amplified by IC12, and the offset is adjusted by R224 so that the level is low when there is no input, and high when there is an input signal. The output of IC12 is passed into the comparator simultaneously with the S-meter output voltage at D101 for noise squelch. This is an S-meter squelch at levels causing large deflections in the S-meter, thus for multi-mode scanning the squelch level can be constantly set to the same value. The dynamic range of the S-meter for FM is the same as deflection for other modes.

16. AF AMPLIFIER

After the squelch output passes through the Q55 pre-amplifier, it is fed into the AF GAIN CONTROL (potentiometer) on the front panel. The AF GAIN CONTROL is located between IC14 and Q55. This means that lowering the variable resistor will reduce the noise down to the level of IC14, and increasing the control setting will provide for sufficient volume.

The tone control in the input section of IC14 allows for the high range of the audio frequency to be increased or attenuated. There is a hole in the bottom cover for the user to set this control to the desired tone level.

17. SSB AND AM MODULATOR

IC6 is as double balanced mixer IC. Carrier suppression of at least 70dB (in relation to the saturation output of the IC) is possible by external fine tuning of the carrier balance. SSB signals are generated by taking a single side band of the DSB output signal of IC6 at F13. AM signals are not filtered, and are generated by disrupting the balance of D6 to allow a carrier to be injected into the DSB signals.

18. FM MODULATOR

A modulation signal is applied to the anode of D75 in the BFO circuit for direct FM modulation.

After the amplitude of the modulation signal is limited by the IC7 IDC circuit, R130 regulates the signal for maximum deviation of less than 5kHz. A subaudible tone input circuit for a repeater is installed at pin 6 of IC7. Modulation of the subaudible tone is set by R131. The subaudible tone is linked to the FM MODE SWITCH, and is only modulated while the FM MODE SWITCH is pressed.

19. CW KEY CIRCUIT SIDE TONE

The CW key is connected to R296, the base resistor of Q61, and the output of Q61 is 8V when the key is pressed. This key ON voltage of 8V is applied to the break-in circuit through D117, and is used for side tone control and oscillation control of the BFO. Q42 is OFF when the key is released during CW transmission. This turns Q41 ON, turning Q39 OFF, and stopping oscillation. When the key is pressed ON, Q42 goes ON, Q41 goes OFF, Q39 goes ON, and the BFO starts oscillation.

Side tone oscillation of approximately 800Hz occurs only while the key is pressed ON. The leading and trailing edges of the waveforms are sloped to eliminate clicking of the monitor sounds. The gate level of IC13 is switched so that the monitor sounds for received signals are louder than during transmission or when the squelch is closed. This side tone passes into the AF pre-amplifier, allowing for the volume to be adjusted with the AF GAIN CONTROL on the front panel. R230 can be used for presetting the volume to its normal level, allowing this volume to be adjusted in the same manner as the AF tone.

20. VOX BREAK-IN CIRCUIT

A portion of the microphone input passes through the pre-amplifier in the PL UNIT, and is passed into the IC17 VOX comparator after the level is controlled by the VOX CONTROL in the switch panel. When there is audio input, there is output from pin 1, Q59 is switched, and C308 is charged. Q62 is switched OFF and the receive mode is selected when the discharge voltage from R292 and the delay variable resistor is less than approximately 4V. The transmit mode is selected when the discharge voltage is less than approximately 4V.

Speaker output passes into pin 5 of IC17 which functions as an anti-VOX amplifier. The anti-VOX output from D115 turns ON Q58, preventing VOX operation.

The 8V key ON voltage output of Q61 passes through D117 before being applied to the base of Q60. Q62 is turned ON to activate the break-in function. The current flows to C309 in the semi-break-in mode to retain the transmit state temporarily. C309 is cut off in the break-in mode and Q62 drives the SEND line with the same timing as the key operation (Refer to the timing diagram on page 5-5).

21. TRANSMISSION IF AMPLIFIER (9MHz BAND)

Q23 is the transmit amplifier, and R361 is a variable resistor for adjusting the total gain for transmitting. ALC with a slow time constant is applied to Q23 to increase the dynamic range for ALC. The thermistor between the Q23 output coil (L75) and the mixer to the 70MHz band provides temperature correction to limit fluctuations in the transmit gain caused by changes in the surrounding temperature.

22. RF AND SWR CIRCUIT

The FOR and REF voltage detected on the FILTER UNIT are fed into the MAIN UNIT from J3. IC15 is a non-inverting amplifier which receives input voltage at high impedance and amplifies it by approximately two. The output series resistor was selected so that the meter is full scale for approximately 35 ~ 40W at the S2 SET position. D107 and C293 comprise a hold circuit to keep the meter deflection for SSB near the peak value. R250 is set so that the meter is not overdeflected at the S2 PO position.

23. ALC AND APC CIRCUITS

The FOR voltage applied to pin 2 of IC16 is compared with the voltage level at pin 3, and amplified to generate the ALC voltage. R274 is the resistor for ALC attack, C300 is the capacitor for hold, and R275 is the resistor for release. The ALC voltage input to pin 6 of IC16 is inverted and amplified

for deflection of the ALC meter. Q56 is a buffer amplifier for external control of this unit's ALC. It prevents fluctuations in the attack time due to varying ALC line impedances.

The protection circuit uses the collector current of the final transmit stage and operates in the following manner.

After the I_c- and I_c+ voltages fed into J2 are split with resistors, the voltage is DC-amplified by IC15. The variable resistor (R262) at the cathode of D110 is adjusted so that Q74 comes ON when the I_c is approximately 20A. If the adjustment value is exceeded, the transmit output is quickly limited to prevent an increase in the current and to protect the final stage.

When the REF voltage rises, it passes through D106 and turns on Q74 in the same manner as I_c APC in order to prevent the REF voltage from exceeding a certain level.

24. POWER SUPPLY CIRCUIT

Signals T8 and R8 are fed out at the proper timing in order to allow the power section of this unit to operate with full break-in. Q63 removes chattering from the SEND line. The relay for external unit standby is switched ON and OFF with the same timing as antenna switching. The timing of each voltage line is shown below.

25. OTHERS

When transverter voltage is applied from ACC, PAT8 is stopped by Q2, Q3, Q4 and Q73 for low level input and output at J13.

Timing diagram of CW operation

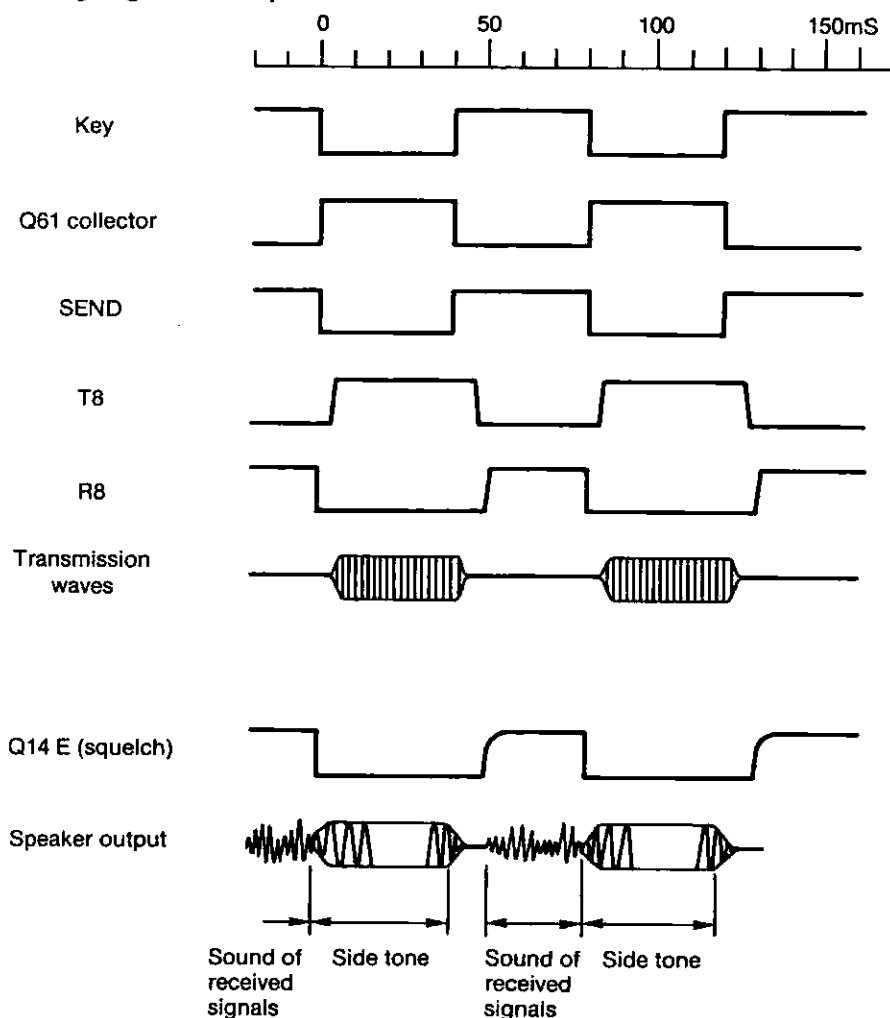

Fig. 4

* Side tone and key are synchronous (leading edge of side tone) and the leading and trailing edges have a sloping of approximately 3 ~ 5ms.

The timing of the various circuits in the break-in mode is shown above.

■ PL UNIT

1. PLL SECTION

This section generates the 1st mixer frequency (1st LO) of 70.5515 to 100.4515MHz (100Hz steps), 2nd mixer frequency (2nd LO) for RIT and D/A conversion (0 ~ 90Hz), and the marker frequency (25kHz). These are all supplied to the MAIN UNIT.

Frequencies of the PLL Section
AM MODE

VCO	Displayed frequency	VCO oscillation frequency
V ₁	0.1000 ~ 7.9999MHz	70.5515 ~ 78.4514MHz
V ₂	8.0000 ~ 14.9999MHz	78.4515 ~ 85.4514MHz
V ₃	15.0000 ~ 21.9999MHz	85.4515 ~ 92.4514MHz
V ₄	22.0000 ~ 30.0000MHz	92.4515 ~ 100.4514MHz

PLL block diagram

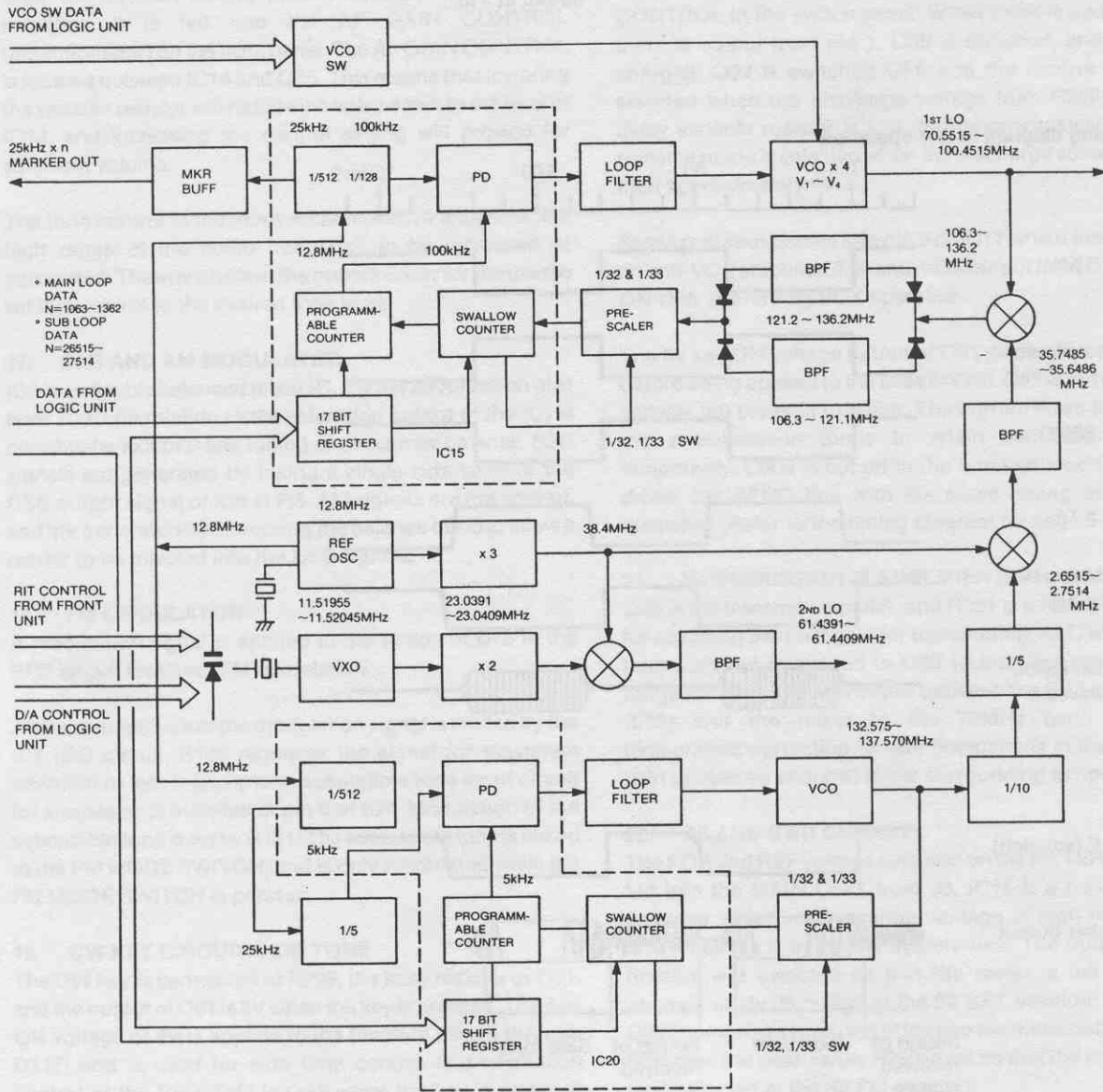

(1) Reference oscillation circuit

The reference frequency is 12.8MHz. The signals from Q43 of the oscillation circuit formed from X2 and Q43 pass through the Q42 buffer amplifier before being passed into IC15 (main loop) and IC20 (sub loop) as the reference. The third harmonic (38.4MHz) is generated and used as the LO within the loop. This is also used as the 2ND LO mixer frequency.

(2) Main loop

The PLL loop which generates the 1ST LO output uses a combination mixer and divider method (Fig. 6).

Main loop

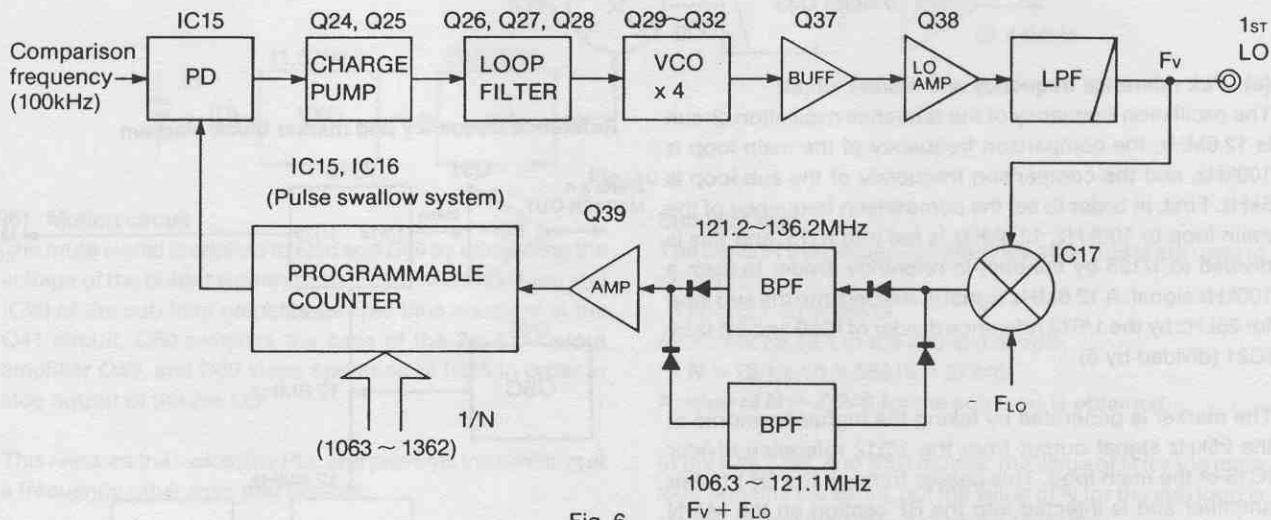

Fig. 6

(a) ICs for the PLL

IC15 (μ PD2834C) is a multi-function IC device which contains a phase comparator, reference divider (1/128, 1/512, and 1/1024), programmable counter, swallow counter, and a control counter for the swallow counter. Pulse swallow division is possible through combining this device with IC16 (μ PB555C prescaler). This allows for a large division ratio and operation as programmable counter up to a high frequency.

(b) VCO

The VCO capabilities are crucial to the PLL. High C/N characteristics cannot be obtained if a PLL has a configuration using a VCO with high noise properties. In order to provide high C/N characteristics and stable oscillation output for this unit, there are four VCOs and the necessary bandwidth is split into four to provide a configuration in which the range of frequency change is appropriate to each VCO. An air-core coil is used for the oscillation coil to provide a high Q factor and to prevent external induction.

Excellent C/N characteristics are provided through circuit design in such areas as ground points, layout of parts, and shielded cases (Photo 1).

Another loop (sub loop, page 5-8) is used to generate the locally oscillated signals (LO within the loop) which are injected into the mixer (IC17) of the main loop.

As the VCO output frequency, F_v , is given by the formula $F_v = N \cdot F_{ref} - F_{Lo}$, the frequency is altered by changing F_{Lo} and N . The comparison frequency, F_{ref} , is 100kHz, and the frequency of the VCO can be controlled in 100kHz steps by altering the division, N , of the programmable counter. Changes in smaller increments (less than 100kHz) are possible by changing F_{Lo} to control the VCO. F_{Lo} can be altered over a range of 99.9kHz in 100Hz steps. This allows for the frequency to be altered up to 29.9MHz in 100Hz steps.

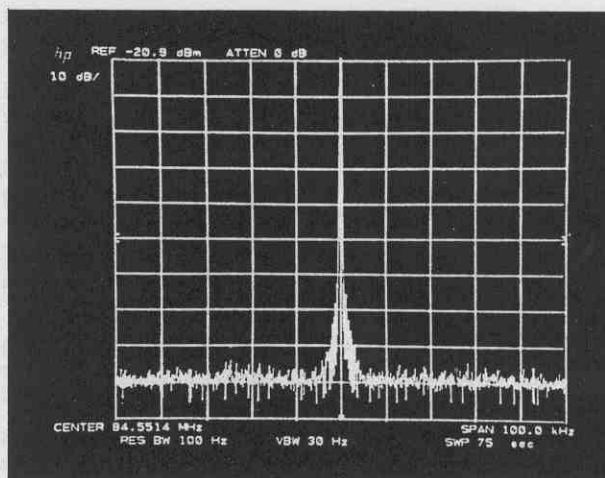

Photo 1 C/N Characteristics

(c) Loops (Refer to Fig. 6)

The output of the VCO passes through the Q37 buffer amplifier, is amplified by Q38, and passes through a low pass filter to be fed out to the MAIN UNIT as the 1ST LO. The output level is approximately 3dBm/50 ohms. The output is also mixed with the sub loop output (LPL) at IC17. The mixed signal passes through the band-pass filters (two types: 121.1 ~ 136.2MHz and 106.3 ~ 121.1MHz). This process removes any spurious signals. The signal is amplified and passes into IC16 to form a lock loop.

(d) LO in the loop

This LO signal is the heterodyne for the VCO signal and allows control of the main loop in 100Hz steps.

As the output frequency of the sub loop is too low (2.6515 ~ 2.7514MHz), the reference oscillation output is multiplied by

three (38.4MHz) and is mixed at IC19 for heterodyne production of the proper frequency and to form the LO signal for the loop. The spurious components of the heterodyne output are removed by the band-pass filter. The signal is then amplified by Q40 and injected into IC17.

LO in the loop

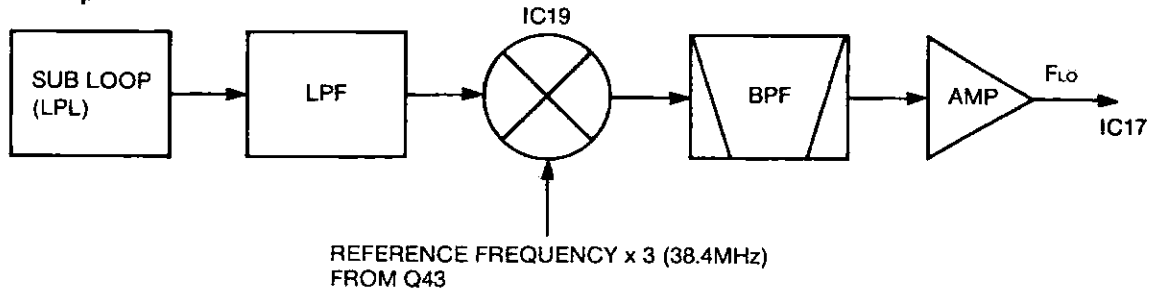

Fig. 7

(e) PLL reference frequency and marker circuit

The oscillation frequency of the reference oscillation circuit is 12.8MHz, the comparison frequency of the main loop is 100kHz, and the comparison frequency of the sub loop is 5kHz. First, in order to set the comparison frequency of the main loop to 100kHz, 12.8MHz is fed into IC15, and this is divided to 1/128 by the built-in reference divider to form a 100kHz signal. A 12.8MHz signal is also fed into the sub loop for 25kHz by the 1/512 reference divider of IC20 and 5kHz by IC21 (divided by 5).

The marker is generated by taking the higher harmonic of the 25kHz signal output from the 1/512 reference divider IC15 of the main loop. This passes through the Q51 buffer amplifier and is injected into the RF section on the MAIN UNIT.

Reference frequency and marker block diagram

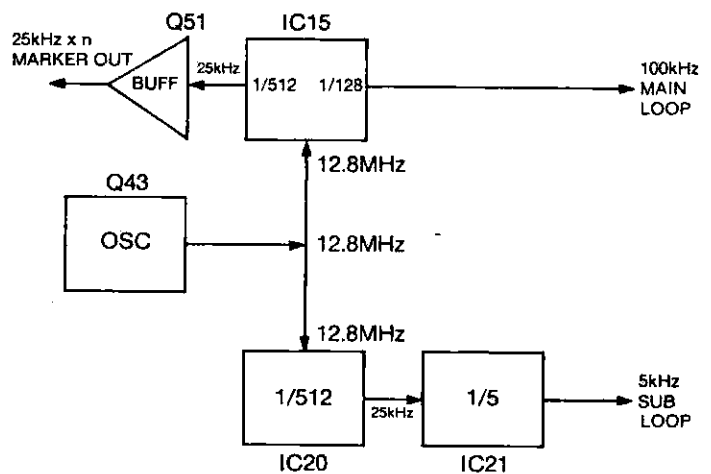

Fig. 8

(3) Sub loop (LPL)

This is a lock loop using the dividing method, which generates the LO signal for the main loop (Fig. 6). The comparison frequency is 5kHz, and the VCO applies a frequency lock between 132.575 and 137.570MHz.

This signal with a variable range of 4.995MHz in 5kHz steps is divided to 1/50 by IC22 and IC23 to generate a signal for the main loop having a variable range of 2.6515 ~ 2.7514MHz in 100Hz steps.

The VCO output is fed into IC22 as well as IC23 and passes through IC20 and the loop filter to form a PLL for control of the VCO. In the same manner as the main loop, this loop uses IC20 and IC21 for pulse swallowing, allowing the frequency to be changed by altering the dividing ratio of the programmable counter.

Sub loop (LPL)

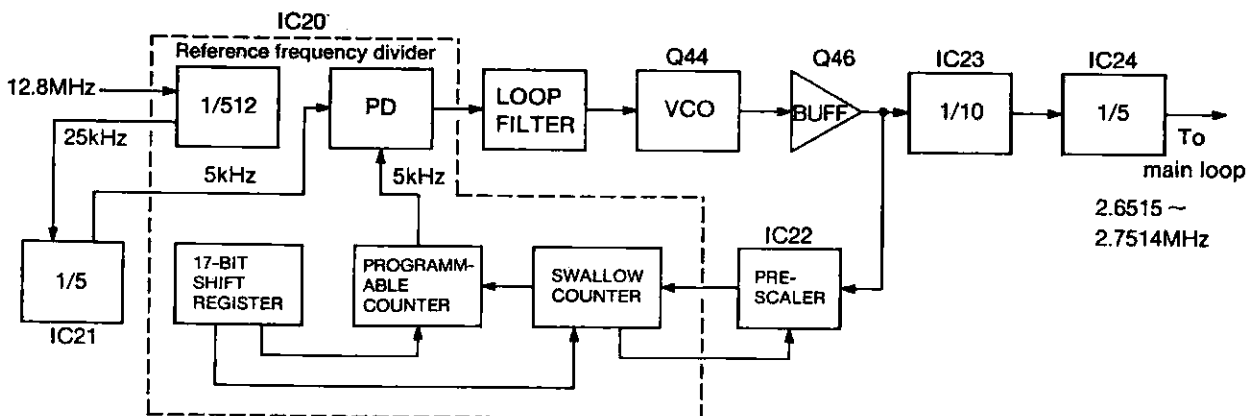

Fig. 9

(4) 2ND LO output

2ND LO is the reference oscillation frequency multiplied by three by X2 and Q43 (38.4MHz), and injected into IC25. X3 and Q47 form a crystal oscillation circuit for the VXO (variable crystal oscillator) used for RIT and D/A conversion. This injects the second harmonic (23.04MHz) of the reference signal to IC25. The output mixed at IC25 has its spurious components removed by the bandpass filter

2ND LO

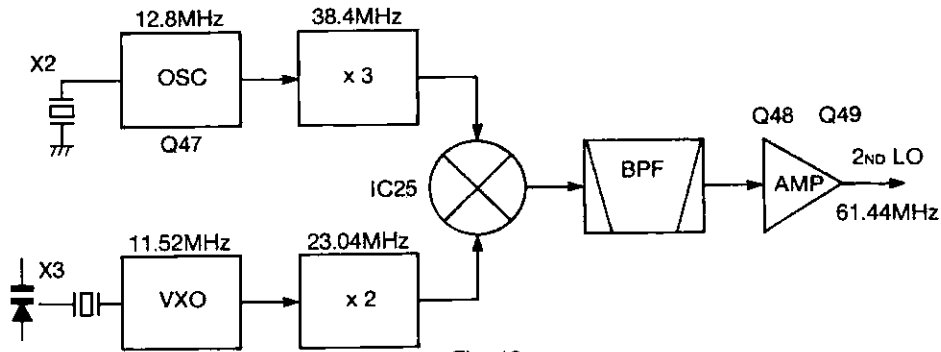

Fig. 10

(5) Muting circuit

The mute signal is applied to Q50 and D89 by converting the voltage of the output signals from IC15 of the main loop and IC20 of the sub loop using the proper time constant in the Q41 circuit. Q50 switches the base of the 2ND LO output amplifier Q49, and D89 stops operation of IC25 in order to stop output of the 2ND LO.

This releases the lock of the PLL and prevents transmitting at a frequency other than that desired.

(6) PLL data

The PLL circuit needs data in order to set the dividing ratio "N" for the programmable counter.

This data is sent from the LOGIC SECTION. The switching signal for VCO is also received from the LOGIC SECTION. N-data is sent as a pure binary code and the LCO switching signal is sent as static data. (Refer to the description of the logic data for the manner in which data is sent.) The frequency shift for the various modes also changes the N-data.

(7) Determining the N-data

As there are two lock loops, there are two types of N-data. Although the frequency displayed in the various modes is the same, the actual frequency of the output signal varies according to the mode. The frequency is the same as displayed for the AM and FM modes, is 900Hz lower for CW, 1.5kHz lower for LSB, and 1.5kHz higher for USB. The N-data for the AM and FM modes is obtained in the following manner.

Displayed frequency AM
14.073.1

Main loop side

The digits of the displayed frequency after 10kHz are discarded to obtain F1.

$$N = F1 \times 10 + 1062$$

As F1 will be 14.0 in the above example,

$$N = 14.0 \times 10 + 1062 = 1202$$

A value of N = 1202 for the main loop is obtained.

formed from L57, C191, C192, C193, and L58, and it is amplified to the required level by Q48 and Q49. The output level is approximately 3dBm/50 ohms.

The D/A converter with the LOGIC UNIT has a range of DC to 90Hz, controlling the 2ND output frequency with the LOGIC UNIT. The RIT can be altered by approximately ± 900 Hz using the RIT variable resistor on the front panel.

Sub loop side

The digits of the displayed frequency after 10kHz are used to obtain F2.

$$N = F2 \times 10 + 26515$$

As F2 will be 73.1 in the above example,

$$N = 73.1 \times 10 + 26515 = 27246$$

A value of N = 27246 for the sub loop is obtained.

In the CW, LSB, and SSB modes, the value of N for the main loop remains the same, but the value of N for the sub loop is altered according to the following formulas.

CW:

$$N = (F2 - 0.9) \times 10 + 26515$$

LSB:

$$N = (F2 - 1.5) \times 10 + 26515$$

USB:

$$N = (F2 + 1.5) \times 10 + 26515$$

The programmable counter performs division of 1/N when the N-data obtained above is given.

(8) MIC amplifier circuit

This circuit amplifies the audio signals from the microphone. The audio signal from the microphone is amplified by Q57 and Q59, the signal adjusted by the MIC GAIN CONTROL is then amplified by Q62 and Q63 before being fed into the MAIN UNIT. Disconnecting W26 allows for use with models such as SM-5 which has a built-in microphone preamplifier. Disconnecting W26 results in a sound having a lower audio low range than the transmit audio tone control. Q58 amplifies the audio signals for the VOX on the MAIN UNIT.

2. LOGIC SECTION

The LOGIC SECTION of the IC-735 uses a high-speed 8-bit CPU providing allocation of the most appropriate I/O ports and software processing. This provides the scanning and 12-channel memory processing functions equal to a much larger unit, using a minimum of peripheral parts. This is a compact transceiver with less-than-compact features.

In addition, battery back-up of the memory channels (including VFO A/B) and other data is provided by a lithium battery. The serial interface in the CPU is to allow an external control device (such as a personal computer) to control the

CPU port allocations

frequency, mode, and VFO/memory channels. The IC-735 includes the new ICOM CI-V COMMUNICATION INTERFACE SYSTEM for use with personal computers. Operation of this section is described below.

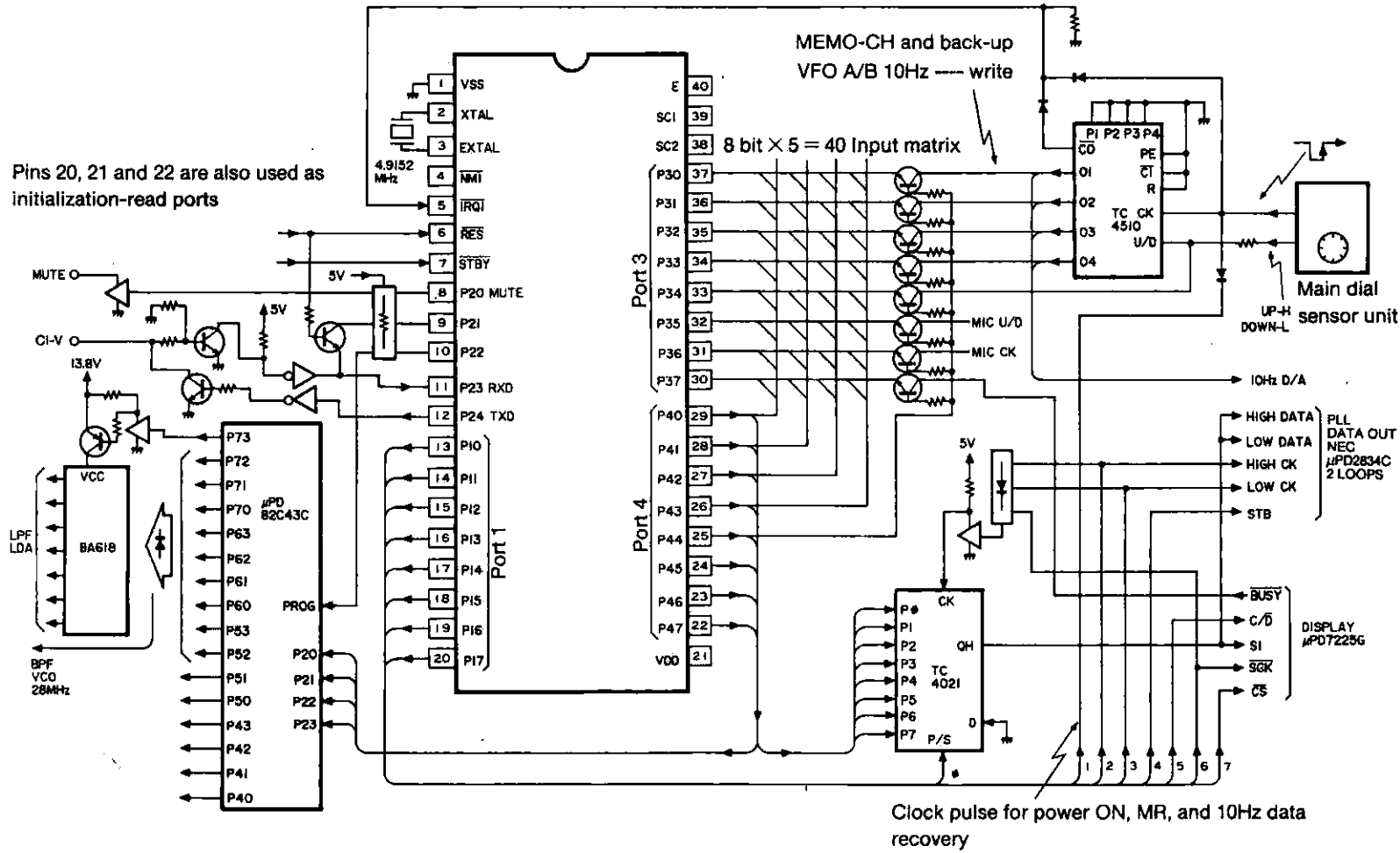

Fig. 11

Reset circuit

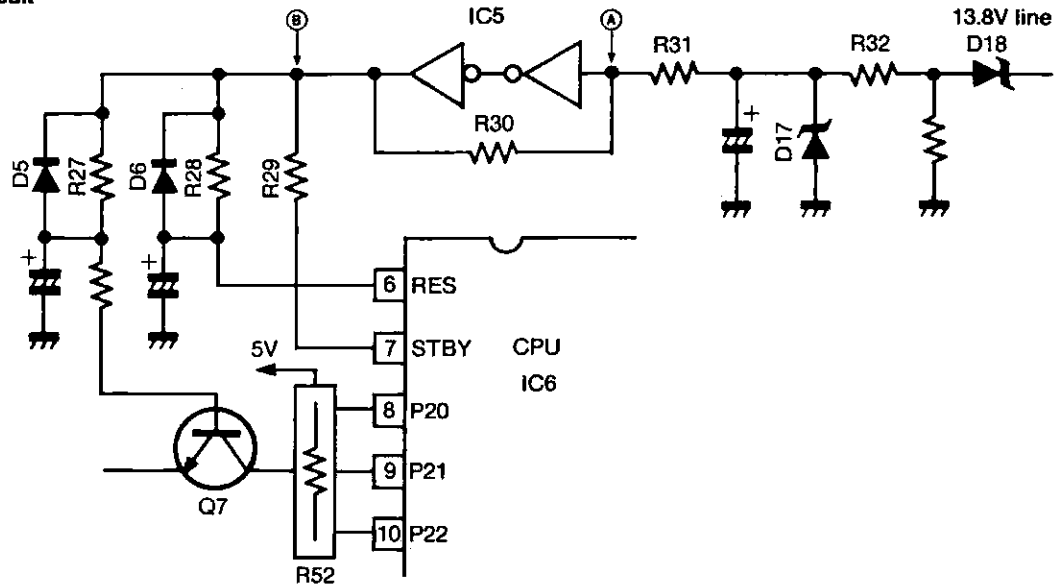

Fig. 12

(1) CPU reset circuit

The CPU reset circuit is connected as shown above, and supplies power from the power supply to reset the CPU. The voltage at point A changes as shown on the graph below as the voltage from the power supply changes.

The Schmidt trigger circuit formed from IC5 is set by R30 and R31 to obtain the following:

High level threshold voltage	2.62V
Low level threshold voltage	2.38V

When the voltage at point A exceeds the threshold voltage, point B is driven to the high level, the CPU is reset, and the operation state is selected.

The CPU operates when the voltage supplied from the power supply reaches 10V. When the voltage drops below approx. 8.2V, the CPU remains in the reset mode and does not operate until the voltage supplied from the power supply reaches 10V again.

A reset time of at least 20ms is required, and pins 20 through 22 must be driven high for initialization while the CPU is being reset.

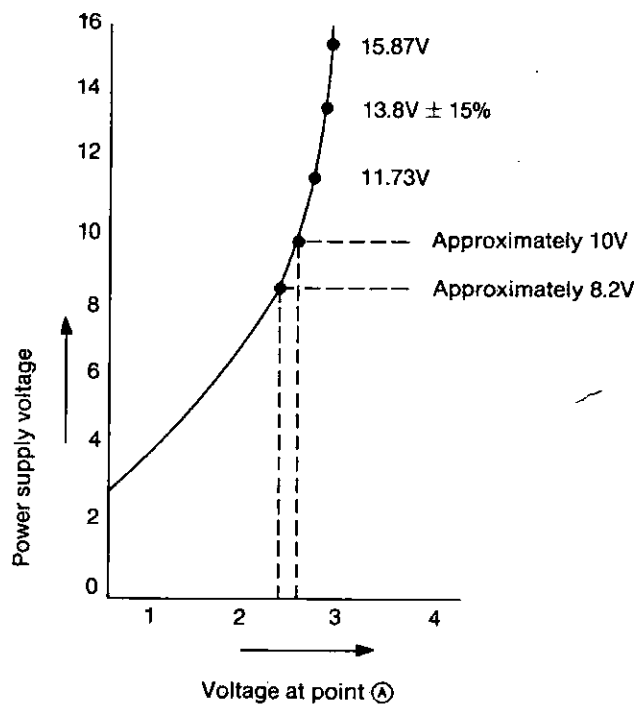

Fig. 13

Sensor and MIC UP/DOWN circuit

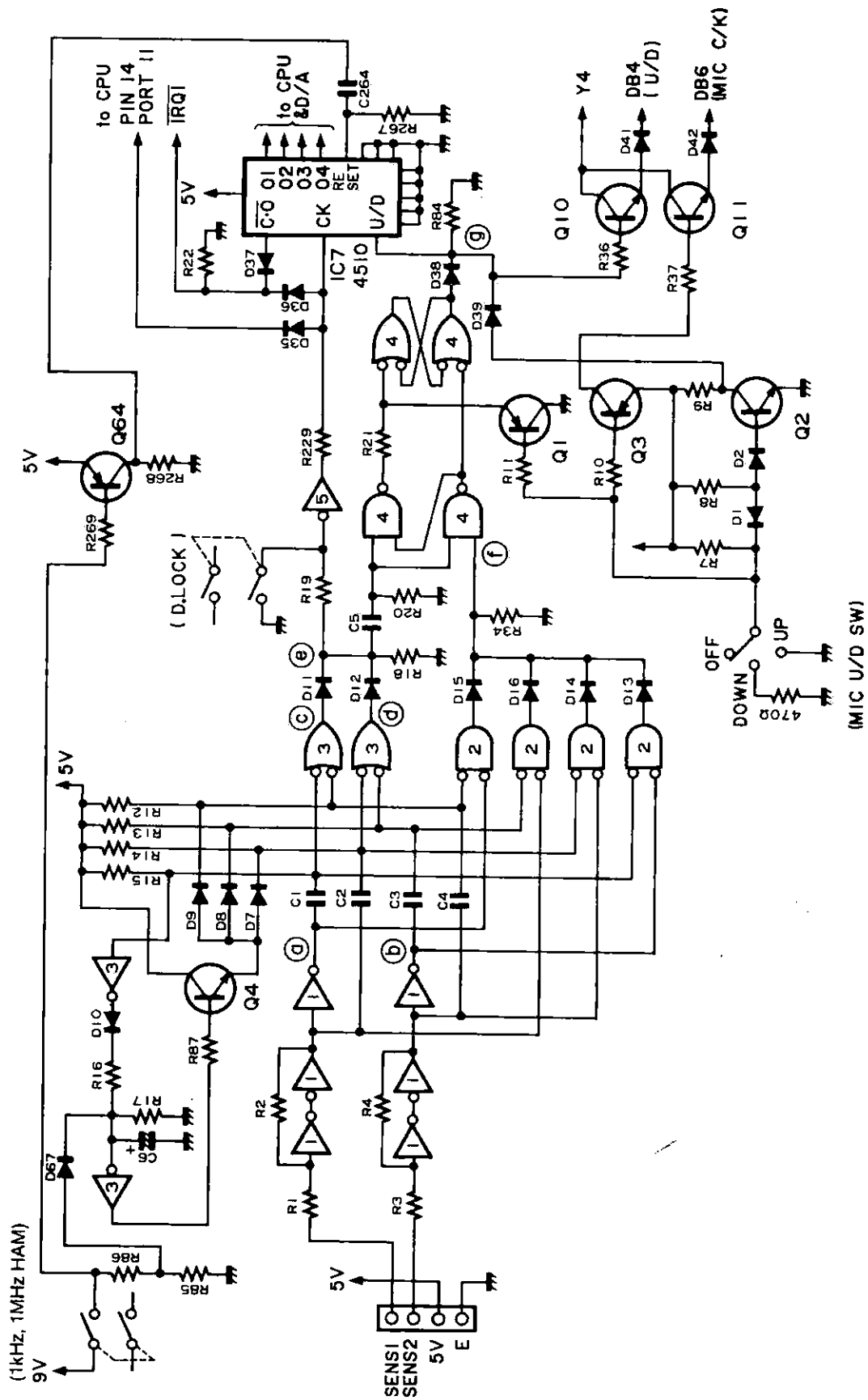

Fig. 14

(2) Sensor circuit

The sensor circuit performs waveform shaping of the dial pulse from the newly developed 250 pulses/revolution sensor unit at the IC1 Schmitt circuit. The pulse-edge detection circuit formed from IC3 automatically switches between normal speed and 4 times speed according to the number of generated pulses (varies according to whether the MAIN DIAL is rotated quickly or slowly).

When the MAIN DIAL is rotated slowly, Q4 is switched ON, pulse output C2 ~ C4 is cancelled by D7 ~ D9, resulting in

Normal speed

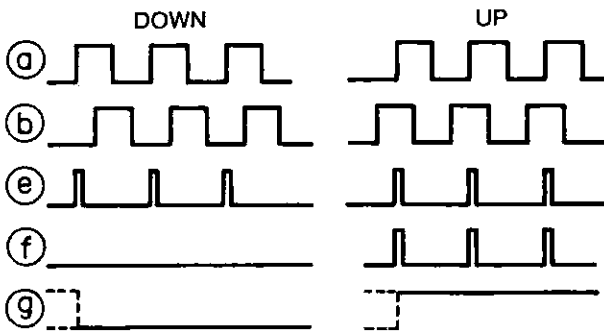

Fig. 15

The detected dial pulses and UP/DOWN signals are counted by the IC7 BCD UP/DOWN counter. The output from this counter is D/A converted from 0 ~ 90Hz for control of the VXO. This data is also written into the frequency data area of the CPU. The output of the counter which has been divided by ten is written via the \overline{IRQ}_1 line into the CPU, for data processing from 100Hz using interrupts.

When the [kHz], [MHz], or [HAM] switch is ON, the 4 times speed mode is automatically selected as the signal flows through D67, C6 is charged, and Q4 is OFF. The D/A section is cleared to zero and held. When [kHz] is ON, the rate is 100 pulses/revolution, and when [MHz] or [HAM] is ON, software in the CPU divides this by ten for 10 pulses/revolution. When the MIC UP/DOWN SWITCH is pressed, Q1 is switched ON and the U/D data of IC4 is cleared. In addition, Q3 is also ON and the MIC UP/DOWN signal is read from Q11. When the MIC UP/DOWN SWITCH is turned ON at the resistor of 470 ohms, Q2 remains ON and DOWN is read into the CPU from Q10. When ON at 0 ohms, Q2 is switched OFF, and UP is read into the CPU.

When [kHz] is OFF, a dummy pulse (111111) is fed out from Port 11 of the CPU and the clock is fed out to IC7. When [kHz] is ON, the frequency is altered by internal CPU processing. As indicated, MIC UP/DOWN is controlled almost totally by CPU software processing. This processing has no effect when either the [MHz] or [HAM] switch is ON. The speed at which the frequency is altered by MIC UP/DOWN can be switched in two stages by digit 0 → DB7 (P4 of J21).

normal speed output of 250 pulses/revolution (shown in ㉔, Fig. 15). When the MAIN DIAL is rotated quickly, current flows through C6 and R17, Q4 is switched OFF, and pulse output C1 ~ C4 is effective for 4 times the speed output of 1000 pulses/revolution (shown in ㉕ in Fig. 16 below).

(3) MIC UP/DOWN circuit

Detection of main movement in the upward and downward directions is made from ㉖ output and ㉗ by the UP/DOWN detection circuit formed from IC4. The detailed truth tables for this operation are shown in Fig. 17 below.

4 times speed

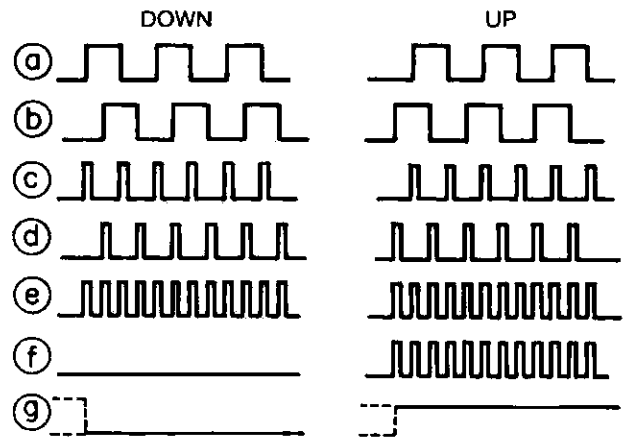
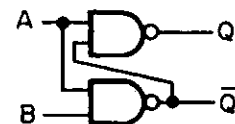
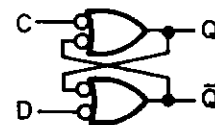

Fig. 16

Truth tables



A	B	Q	\bar{Q}
0	0	1	1
0	1	1	1
1	0	0	0
1	1	0	0



C	D	Q	\bar{Q}
0	0	1	1
0	1	1	0
1	0	0	1
1	1	Latch	Latch

Fig. 17

(4) PLL and display data

(a) PLL (μ PD2834C) data

Although the PLL and display data must be sent serially to the various ICs, the CPU processes it in bit units in parallel form. The data which has been internally processed in the CPU is fed out from port 4 into IC8 which is a TC4021BP shift register from parallel to serial converter.

Both data and clock pulses must be sent to the various PLL and display ICs. Data is fed out from P₁₂, P₁₃ and P₁₆ of Port 1 of the CPU. The clock pulses are then sent to the ICs, and the same clock is used simultaneously by the IC8 shift register for conversion of parallel data to serial data.

Fig. 18 shows an actual measurement of PLL data. The PLL has both a HPL and LPL system.

PLL (μ PD2834C) data

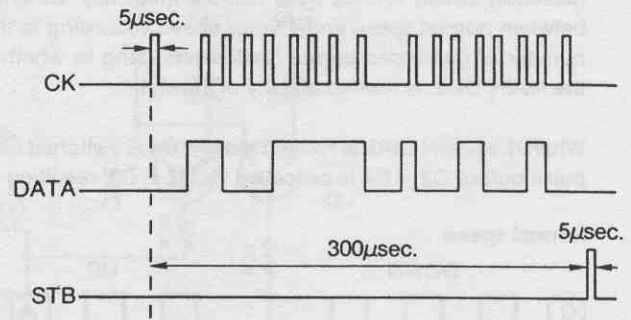

Fig. 18

(b) Display (μ PD7225G) data

Fig. 19 is a timing diagram that shows an actual measurement of display data. A total of 11 bytes of display data are sent in single byte units. The CPU checks for a BUSY signal (column 4 → D7) each time it sends a byte of data.

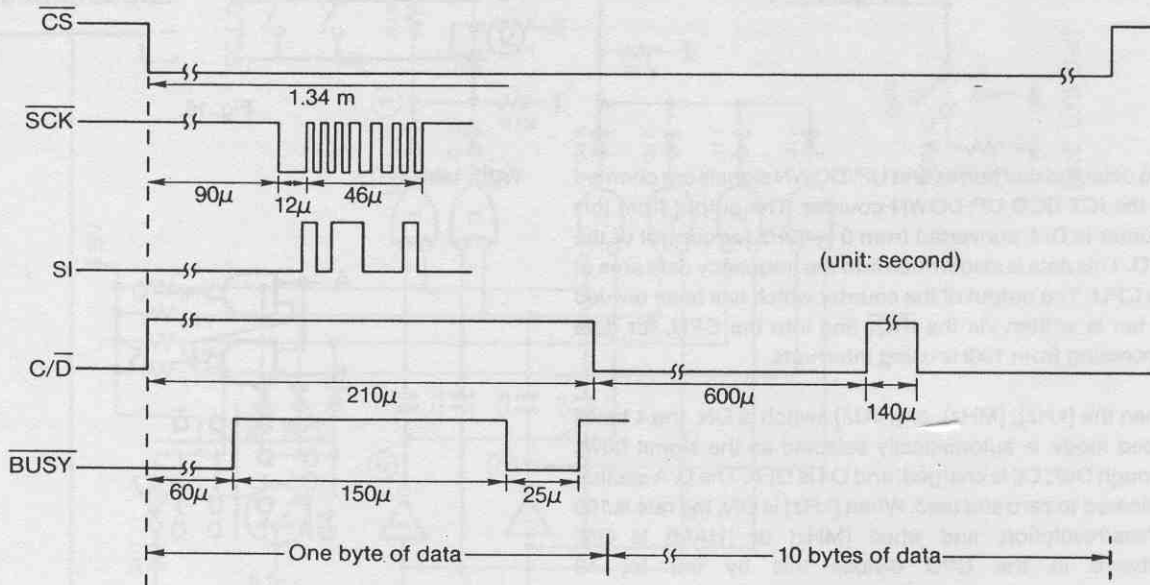

Fig. 19

Frequency ranges

RX/TX	Frequency range [MHz]	Remarks
RX	0.1 ~ 30	RX: Frequency range allowing reception
TX	1.8 ~ 1.999.9	TX: When attempting to transmit outside the transmit frequency range, the PLL lock will be unlocked as the N-data from the CPU will not be proper.
	3.4 ~ 4.099.9	
	6.9 ~ 7.499.9	
	9.9 ~ 10.499.9	
	13.9 ~ 14.499.9	
	17.9 ~ 18.499.9	
	20.9 ~ 21.499.9	
24.4 ~ 25.099.9		
27.9 ~ 30.0		

BPF, LPF, VCO, and LDA classifications

Frequency range [MHz]	BPF	LPF	VCO	LDA	Remarks
0.1 ~ 1.599	1	1	1	1.9M	μPD82C43 is used as an I/O EXPANDER
1.6 ~ 1.999	2			3.5M	
2.0 ~ 3.999	3			7M	
4.0 ~ 7.999	4			10M	
8.0 ~ 10.999	5	4	2	14M	
11.0 ~ 14.999	6			21M	
15.0 ~ 21.999	7	5	3	24.28M	
22.0 ~ 27.999	8	6	4	24.28M	
28.0 ~ 30.0					

(c) Shift in PLL data according to mode

The IC-735 differs from previous transceivers in the fact that the displayed frequency remains the same and is not shifted when the mode is changed.

The N data for the PLL is shifted in relation to the displayed frequency to maintain the carrier frequency at the same value.

Displayed frequency: constant

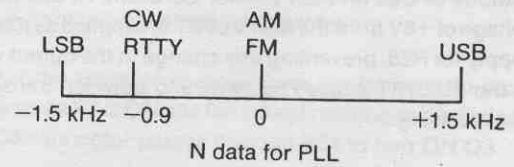
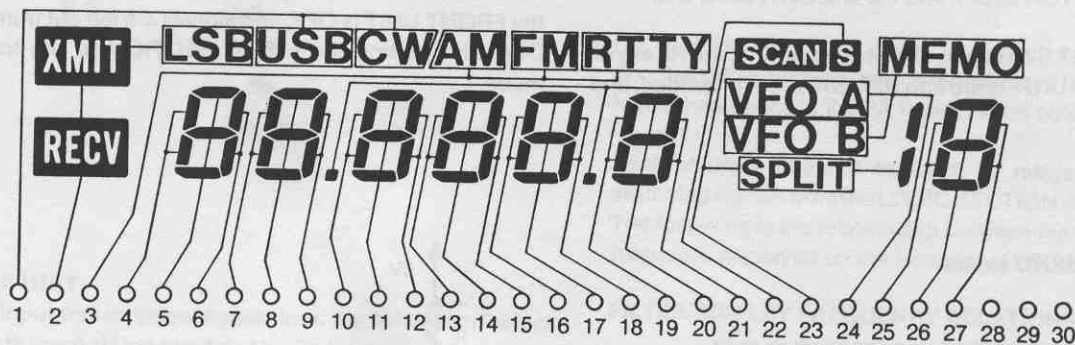

Fig. 20

(d) LCD display

The display uses a large LCD for high visibility, and a μPD7225 is used as the driver with a cycle of 1/3 duty and 1/3 bias.



Refer to table below

COM	Segment	7-segment digit
0	LSB, USB, RTTY, MEMO ×10 for memory (1) and decimal point (.)	
1	XMIT, CW, AM, SCAN, S, VFO A	
2	RECV, FM, VFO B, SPLIT	

■ FRONT UNIT

This unit consists of a switchboard and variable resistor board. The switchboard contains display related components, the METER circuit, controls for analog control, switches for LOGIC control, MATRIX circuit, RIT circuit, DIMMER circuit, and SEND circuit. The variable resistor board contains the microphone connector, headphone jack, controls for volume and squelch levels, and the control for the dimmer.

The display related components and MATRIX circuit comprise the LOGIC SECTION. As these switches and controls have already been described above (see page 5-10), this section will deal with the remaining circuits.

(1) RIT circuit

When the RIT is OFF, the base of Q2 will be grounded preventing operation of Q2 in both the transmit and receive modes. The voltage determined by R28, R18, and D3 is passed into the cathode of D4 on the PL UNIT constant. At this time, the voltage of +8V from the MAIN UNIT is supplied as the power supply for R28, preventing any change in the output voltage to the PL UNIT caused by switching between transmitting and receiving.

Adjustment is performed by first turning ON the RIT SWITCH, setting the RIT CONTROL to its mechanical center, turning ON the kHz SWITCH on the front panel and then by adjusting L53 of the PL UNIT so that the 2ND LO output is 61.44MHz at Q46 (PL UNIT) when the D/A signal of the LOGIC SECTION is not applied to the anode of D88.

Next, adjust R18 so that the 2ND LO output is 61.44MHz when the RIT SWITCH is OFF and the kHz SWITCH is ON.

When the RIT SWITCH is ON while receiving, the R8 signal of the MAIN UNIT is fed into R27. S10 is not grounded, and

thus the voltage determined by R27, R17, R19, and D4 is passed into the cathode of D4 to alter the 2ND LO frequency, changing the receive frequency. Q2 remains OFF even when the RIT SWITCH is ON while transmitting. 2ND LO is controlled by the voltage output from D3, and the output frequency of 2ND LO is equivalent to when RIT is OFF.

RIT circuit

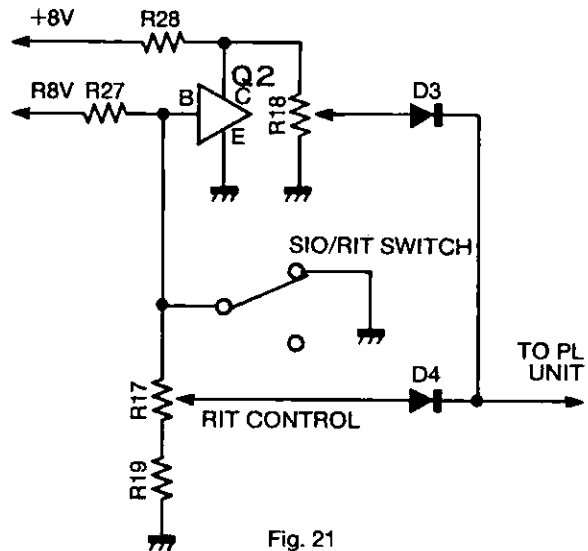

Fig. 21

(2) SEND circuit

This circuit keeps the TX and RX timing of the MAIN UNIT and LOGIC SECTION equivalent to each other.

Q6 is ON when the XMIT SWITCH is OFF, and as no voltage is supplied to the collector of Q5, signals are not fed out from Y0 to DB4, and both the MAIN UNIT and LOGIC SECTION are in a received state. When the XMIT SWITCH is ON, T8 REG of the MAIN UNIT operates and at the same time, Q6 of the FRONT UNIT is OFF, and signals are fed out from Y0 to DB4, also setting the LOGIC SECTION to the transmit mode.

SEND circuit

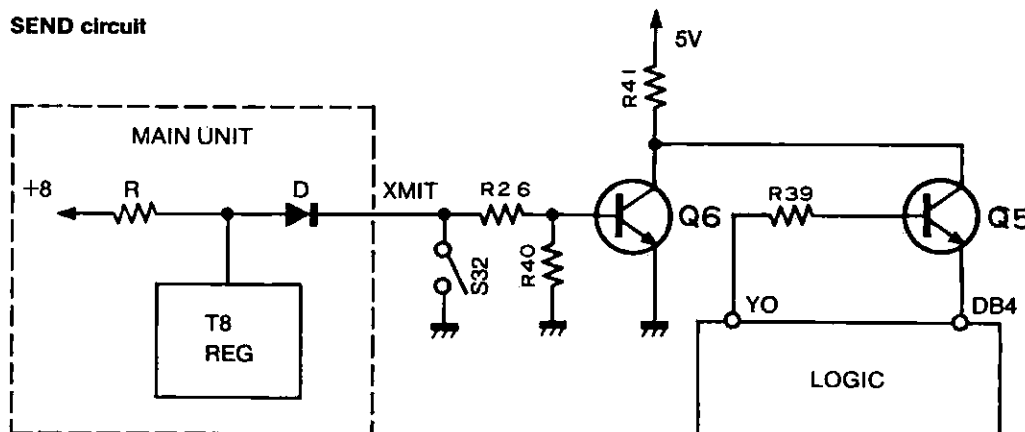

Fig. 22

(3) METER switching circuit

IC1 is used for switching between transmit and receive. The R8 signal is fed into pin 5, current flows through pins 3 and 4, and the selected meter is the signal meter. When the T8 signal is fed into pin 13, current passes through pins 1 and 2, and the PO meter, SWR meter, and ALC meter are selected.

(4) DIMMER circuit

This circuit allows the illumination level of the meters and display to be externally controlled.

The output voltage is split at controls R33, R35, and R34, applied to the base of Q4, and the final output voltage is determined by this voltage, the junction voltage of Q4, and the Zener voltage (approximately 8.2V) of D27. The variable range of the voltage is from less than 9V to 12V.

DIMMER circuit

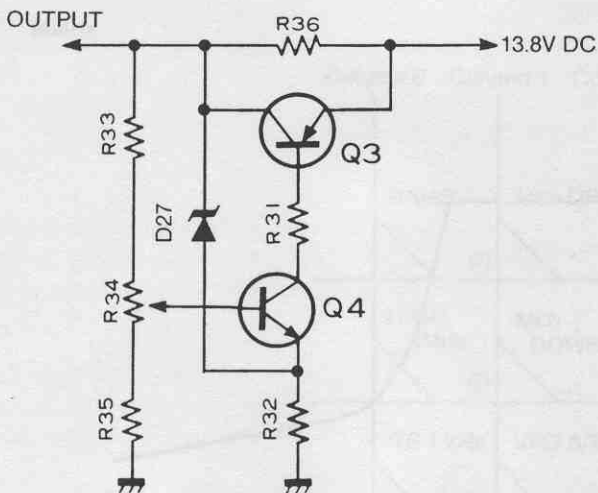

Fig. 23

■ PA UNIT

The input transmission signals from the MAIN UNIT which pass through P1 are amplified by Q1 (class A). The resultant signal is equivalent converted by L1, and amplified by the class AB push-pull circuit comprised by Q2 and Q3. The idling current of Q2 and Q3 is controlled by the junction voltage of D1, and is set by R8 to be approximately 100mA. D1 is thermocoupled to Q3, and performs temperature compensation for Q2 and Q3. C7, C8, R11, and R12 apply negative feedback to Q2 and Q3 to keep the gain constant in relation to changes in frequency.

Next, the impedance is converted by L4 and passes through the final amplifier (Q5 and Q6) for output of 100W. A portion of the output of Q5 and Q6 is fed back by the feedback transformer L19 to prevent variations in gain at different locations within the band. The idling current of Q5 and Q6 uses the junction voltage of the thermocoupled D2 and D3 for control. The current is set at approximately 600mA by R19.

The output impedance of the final amplifier is converted by L20 and the signal is applied to the FILTER UNIT.

(1) PROTECTION circuit

Temperature switches S1 and S2 are designed to operate at 90°C and 50°C respectively, and fan rotation is controlled by these switches in the transmit/receive state.

Voltage of 8V is applied to D6 during transmission, turning on Q9 and Q8, and supplying voltage to fan MF1 through R31. When S2 is activated, R31 and R44 are connected in parallel and the voltage drop between the Q8 connector and MF1 is reduced, speeding up fan rotation.

Even if the transceiver goes from the transmit to receive mode while S2 is ON, the fan is kept rotating as the voltage at the Q8 connector passes through R34 to turn ON Q9.

When the surrounding temperature rises, due to use within a vehicle, etc., no voltage is supplied to the fan until the transceiver is set to transmit, even when S2 is activated. Activation of S1 causes fan rotation to increase in speed. R26 is a resistor for current detection. It detects the potential at both sides and is amplified by IC15b on the MAIN UNIT. The amplified voltage is applied to Q74, and controls output power as an Ic APC function.

(2) FILTER unit

Six Chebishev-type low pass filters are used to suppress the higher harmonics in the PA transmission output.

Each of these filters is operated by relays activated by switching signals from the LOGIC SECTION of the PL UNIT. The following is the relationship between the filters and the frequency displayed on the front panel LCD:

FILTER/DISPLAY FREQUENCY RELATIONSHIP

Filter	Frequency
L1	0.1 to less than 2MHz
L2	2 to less than 4MHz
L3	4 to less than 8MHz
L4	8 to less than 15MHz
L5	15 to less than 22MHz
L6	22 to 30MHz

The transmit output from the low-pass filter passes through the SWR detection circuit and reed-relay RL13 before being fed out to the J4 antenna connector. If the SWR value rises,

Q74 in the MAIN UNIT is controlled by the REF voltage (P4-2) of the SWR detection circuit and applies SWR APC.

The receive signals from J4 pass through low-pass filter L50 before being fed out to the MAIN UNIT.

(3) Die-cast heat sink

The IC-735 is equipped with die-cast heat sinks on the PA UNIT and FILTER UNIT. They are larger than those of conventional HF transceivers, and there are many fins on the reverse side of the PA and FILTER UNITS for effective heat radiation.

The graph below sketches the heat radiation characteristics of these die-cast heat sinks.

The input transmit signals from J14 of the MAIN UNIT which pass through P1 are amplified by Q1 (class A). The resultant signal is impedance and balance converted by L1 and fed into Q2 and Q3. The circuit of Q2 and Q3 is an AB class push-pull circuit which has a feedback circuit comprised of L10, L11, R11, R12, C7, and C8. The idling current for this circuit is controlled through use of the junction voltage of D1, which is thermocoupled to Q3 and set by R8 at approximately 100mA.

Next, the impedance is converted by L4 to 50 ohms output from the PA UNIT, and the signal passes into the FILTER UNIT.

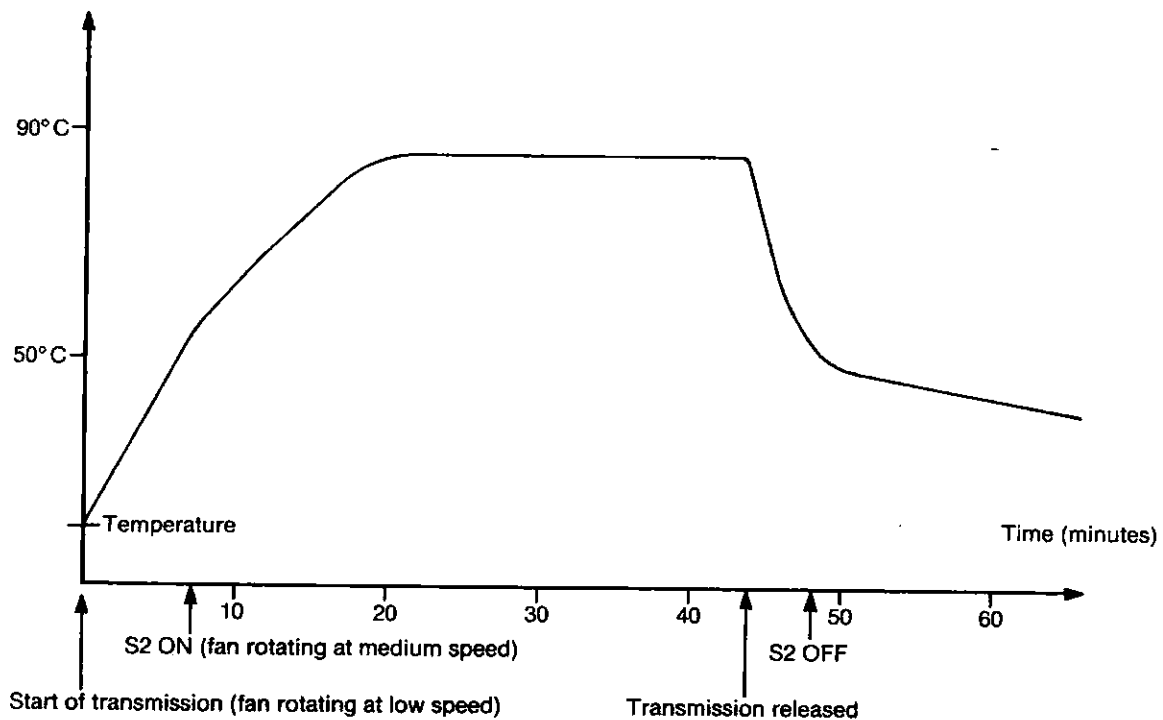
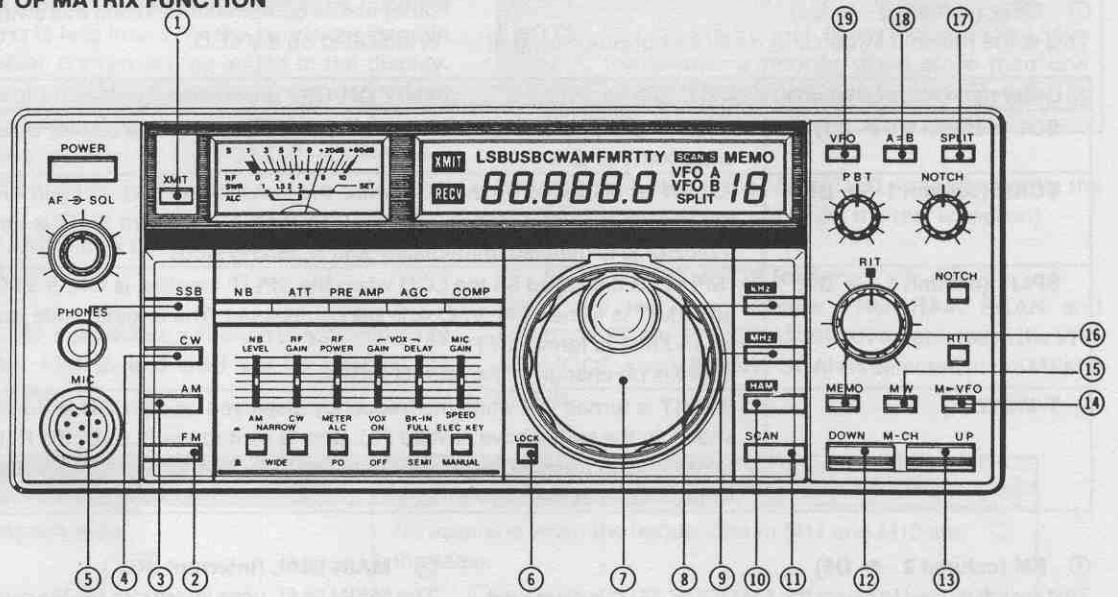

Fig. 24

THEORY OF MATRIX FUNCTION



Matrix

Column 0 Column 1 Column 2 Column 3 Column 4

	Column 0	Column 1	Column 2	Column 3	Column 4	
	BAND	Mch UP	LSB	Remote control address 0	10Hz D/A input 1	D ₀
	HAM/1MHz	Mch DOWN	USB	1	2	D ₁
	TS 1 kHz	VFO A/B	CW	2	4	D ₂
	SQL	MEMORY READ	AM	Remote transceiver control	8	D ₃
	SEND	A=B M → VFO	RTTY	0	DIAL U/D	D ₄
	TIMER SCAN	MW	FM	1		D ₅
	P, M SCAN SPEED	SCAN START/STOP	SSB		MIC CK	D ₆
	MIC UP/DOWN SPEED	SPLIT	MODE-S		DISPLAY μPD7225G BUSY	D ₇

Ⓛ: LOCK SWITCH

Fig. 21

1. FRONT PANEL OPERATION (MATRIX INPUT)

① XMIT (column 0 → D4)

This is the transmit switch and it carries out processing of

other matrix combinations. When this switch is ON, "XMIT" is indicated on the LCD.

Other matrix combinations	XMIT ON/OFF processing
SQL (column 0 → D3)	"RECV" is indicated on the LCD when SQL is OFF, but this display does not appear while XMIT is ON.
SCAN (column 1 → D6)	"SCAN" is displayed on the LCD while the transceiver is scanning in PROGRAM SCAN (VFO) and MEMORY SCAN (MEMO) MODES. When XMIT is turned ON, this indicator is eliminated immediately and scanning stops.
SPLIT (column 1 → D7)	"SPLIT" is displayed on the LCD when the SPLIT function is ON. If VFO is selected and XMIT is turned ON, VFO A/B will be reversed. The original state is returned to when XMIT is turned OFF. There is no change in the MEMO MODE.
T-MUTE	If XMIT is turned ON while the frequency displayed on the LCD is outside the range shown in the table above, invalid PLL data is sent to the PLL IC, the PLL lock is released, and transmitting is no longer possible. Normal PLL data is then sent again when XMIT is turned OFF.

② FM (column 2 → D5)

This switch is used to select the FM MODE. "FM" is displayed on the LCD when this switch is pressed.

③ AM (column 2 → D3)

This switch is used to select the AM MODE. "AM" is displayed on the LCD when this switch is pressed.

④ CW (column 2 → D2)

This switch is used to select the CW MODE. "CW" is displayed on the LCD when this switch is pressed.

⑤ SSB (column 2 → D6)

USB is selected when the frequency displayed on the LCD exceeds 10MHz, and LSB is selected when it is less than 10MHz. USB and LSB are reversed when the SSB MODE SWITCH is pressed while the transceiver is in either of the single side-band modes (USB or LSB).

The mode switches can be used to switch modes while the unit is in any state. Increasing or decreasing MEMO-CH numbers while MODE-S (shares same switch as DIAL LOCK) is ON will result in selection of only those MEMO channels which have the same mode as that displayed on the LCD. Memory channels having different modes will be skipped. In the same manner, MODE-S SCAN will result in scanning only those channels having the same mode as indicated on the LCD.

Unlike previous models, even if the mode is changed in the IC-735, the indicated frequency will remain the same and only the N data for the PLL will be shifted. (See Fig. 20, p.5-15)

⑥ DIAL LOCK/MODE-S (column 2 → D7)

Pulses from the MAIN DIAL SENSOR UNIT are stopped by hardware circuitry and the DIAL LOCK FUNCTION is deactivated.

MODE-S is also activated when the DIAL LOCK function is turned ON, allowing for the MODE SELECTION functions described above in SSB ⑤.

⑦ MAIN DIAL (Interrupt \overline{IRQ}_1)

The MAIN DIAL uses interrupts for processing which is the fastest and has the highest priority. Frequency tuning with high operability is made possible through the use of ICOM's newly-developed encoder which generates 250/1000 pulses for each revolution of the dial.

Quick QSX is possible using switches ⑧ through ⑩.

⑧-⑩ OFF

Slowly rotating the dial will change the frequency effectively in 10Hz steps at the rate of 250 pulses/revolution, 2.5kHz for each complete revolution of the dial.

Rotating the dial quickly allows for quick scanning within the band with steps of 10Hz at the rate of 1000 pulses/revolution, 10kHz for each complete revolution.

⑧ TS 1kHz (column 0 → D2) ON

Frequency changes are in 1kHz steps with each complete revolution of the dial equivalent to 100kHz. This is effective for use in FM MODE and for large changes in the frequency.

x10Hz and x100Hz are both automatically cleared to 0.

⑨ MHz (column 0 → D0) ON

The change in frequency is in 1MHz steps with each complete revolution of the dial equivalent to 10MHz. This allows the frequency to be altered in 1MHz units.

The values between x100kHz and x100Hz do not change; only those greater than x100kHz do.

⑩ HAM (column 0 → D0/D1) ON

The ham bands are switched in the following manner, 10 bands for each complete revolution (see page 15-21):

The values for x100kHz to x100Hz do not change, but if the value of x100kHz is less than 5 for the bands enclosed in parenthesis above, 500kHz will be added to the display. When the value of x100kHz is 5 or greater for the following bands not enclosed in parenthesis, 500kHz will be subtracted from the display: (1.8M)—(3.5M)—7M—10M—14M—18M—21M—(24.5M)—28/29M

For 28/29 MHz, 500kHz is not added or subtracted from the x100kHz value.

If the mode is SSB, LSB will be switched to automatically for bands below 10MHz, and USB will be selected for bands above 10MHz.

NOTE: Switches ① through ⑩ are lock-type and have the following priority when more than one switch is pressed simultaneously: ① < ⑨ < ⑩

Scanning will stop if the MAIN DIAL is rotated while the IC-735 is scanning (except when the dial is locked).

⑩ SCAN START/STOP (column 1 → D6)

There are two scan modes: PROGRAM SCAN and MEMORY SCAN. PROGRAM SCAN is selected in the VFO A/B MODE, and MEMORY SCAN is selected in the MEMO MODE.

Scan	Scan function
Program scan	<p>No scanning when the frequencies in M11 and M12 are the same.</p> <p>Frequencies between M11 and M12 are scanned. (No scanning when M11=M12.)</p> <p>The modes for M11 and M12 have no relation to the scan modes. Scanning is performed in the current mode in the VFO.</p> <p>Scanning is performed in the UP (increasing) direction from the lower frequency to the higher frequency, regardless of which MEMO-CH (M11 or M12) contains the higher frequency and which contains the lower frequency.</p> <p>If the displayed frequency is between M11 and M12, scanning continues upward from the displayed frequency. Scanning begins from the lower of the two frequencies if the displayed frequency is not between M11 and M12.</p> <p>Scanning is in 1kHz steps when TS 1kHz is ON, and in 100Hz steps when OFF.</p>
Memory scan	<p>Scans in the upward direction from M1 to M12.</p> <p>Scanning starts from the displayed MEMO-CH, and when MODE-S (column 2 → D7) is ON, only those MEMO-CH having the same mode as displayed are scanned.</p>

Scanning stops if the SCAN SWITCH is pressed again during scanning. Scanning also stops when any of the following operations are performed:

- MEMO-CH UP/DOWN.
- MIC UP/DOWN (operation of UP/DOWN SWITCH on the microphone).
- MAIN DIAL is rotated (except when dial is locked).
- XMIT (or PTT) is turned ON for transmitting.

"SCAN" is displayed on the LCD during scanning, and the indicator is extinguished when scanning is stopped.

Scanning will not start when the transceiver is transmitting, even if the SCAN SWITCH is pressed.

The following matrix combinations are also available to make scanning even more convenient (see page 5-22):

Matrix	Function
Timer scan (column 0 → D5)	When this matrix combination is ON, the squelch is activated during scanning when a signal is detected. Scanning stops on this frequency but the "SCAN" indicator does not disappear. After stopping for approximately 10 seconds on this frequency, scanning automatically starts again.
PM scan speed (column 0 → D6)	This allows for the scan speed to be switched between fast and slow speed. The scan speed is slow when this matrix combination is ON.

⑫ **MEMO-CH DOWN** (column 1 → D1)

⑬ **MEMO-CH UP** (column 1 → D0)

The MEMO-CH UP/DOWN SWITCHES are used to switch MEMO channels.

In the VFO mode only the MEMO-CH number on the right side of the LCD display is switched.

In the MEMO-CH mode not only is the MEMO-CH number on the right side of the LCD display switched, but the contents of the selected MEMO-CH are displayed.

When the MEMO-CH UP/DOWN SWITCHES are pressed once, the MEMO-CH will be increased or decreased by a single channel. Pressing the MEMO-CH UP/DOWN SWITCHES continuously will cause the MEMO-CH to change continuously. If the MODE-S (column 2 → D7) function is ON, only those MEMO channels having the same mode as that displayed will be selected, and channels having other modes will be skipped.

Pressing the MEMO-CH UP/DOWN SWITCHES during scanning will stop the scanning function.

⑭ **M → VFO** (column 1 → D4/D5)

The contents of the MEMO-CH number displayed on the right side of the LCD are shifted to the VFO.

Pressing this switch in the VFO MODE will shift the MEMO-CH contents to that VFO (contents of the MEMO-CH remain the same).

In the MEMO-CH MODE, the contents of the MEMO-CH currently being displayed are to the VFO (A or B) which was in use immediately prior to switching to the MEMO-CH mode (contents of the MEMO-CH remain the same).

⑮ **MW** (column 1 → D5)

MW stands for "memory write". The frequency and mode (regardless of VFO or MEMO-CH MODE) currently being displayed are written into the MEMO-CH having the number indicated on the right.

⑯ **MEMORY READ** (column → D3)

This switch is used to switch from the VFO mode to the MEMO-CH MODE. When the switch is pressed, the "VFO-A" or "VFO-B" indicators are eliminated and "MEMO" is displayed to indicate the MEMO-CH MODE.

In the same manner as the VFO state, the frequency and mode can be changed for each MEMO-CH, but the contents of the MEMO-CH remain the same until MW (column 1 → D5) is pressed.

(Even when the frequency and mode are changed, switching to another MEMO-CH and then back to the original MEMO-CH will result in the stored contents being displayed.)

⑰ **SPLIT** (column 1 → D7)

Pressing this switch will display "SPLIT" on the LCD and switch to VFO A/B for split operation.

VFO A/B returns to its original setting when the transceiver goes back to transmit mode.

In the MEMO-CH MODE, nothing changes when transmit is selected.

Pressing the switch again while (SPLIT) is being displayed will eliminate the indicator and release the function.

⑱ **A = B** (column 1 → D4)

Pressing this switch in the VFO MODE will shift the contents of the VFO currently being displayed to the VFO not being displayed, making the contents of both the same.

This switch has no effect in the MEMO-CH MODE.

⑲ **VFO A/B** (column 1 → D2)

Pressing this switch in the VFO MODE will switch the transceiver between VFO A and VFO B. (The LCD display changes to "VFO A" or "VFO B").

If this switch is pressed in the MEMO-CH MODE, the "MEMO" indicator is eliminated and the IC-735 returns to the VFO used immediately before MEMO-CH was switched to.

2. DESCRIPTION OF ADDITIONAL MATRIX INPUT

(1) SQL (column 0 → D3)

This is related to the position of the SQL CONTROL on the front panel. The squelch is activated (matrix combination OFF) when a signal is detected and "RECV" is displayed on the LCD. Scanning stops if a signal is detected during scanning.

The "RECV" indicator is eliminated when the SQL is closed (matrix combination ON) or transmitting begins (SEND column 0 → D4 is ON). (Refer to ① XMIT and ② SCAN.)

(2) MIC UP/DOWN SPEED (column 0 → D7)

The frequency can be increased or decreased by pressing the switch on the microphone. This function switches the speed at which the frequency changes. The speed is SLOW when the matrix is ON and FAST when OFF.

(3) DIAL UP/DOWN DATA (column 4 → D4)

When a MAIN DIAL (interrupt) or MIC UP/DOWN clock signal is input, UP processing is performed if the U/D data is ON, and DOWN processing is performed when the U/D is OFF.

(4) MIC UP/DOWN CLOCK (column 4 → D6)

When a MIC U/D clock signal is generated (by pressing the MIC SWITCH), the frequency is changed in 10Hz steps from Port 11 (pin 14) of the CPU when TS (column 0 → D2) is OFF, and in 1kHz steps when TS is ON. (Refer to Fig. 14, page 5-12).

Continuous generation of MIC U/D clock signals will cause the frequency to continuously change. This change can be controlled at two speeds (FAST/SLOW) by jumper selection. The control signal is the MIC U/D SPEED (column 0 → D7).

(5) DISPLAY BUSY (column 4 → D7)

BUSY signals are sent to the CPU in order to inhibit/permit the input of serial data. This makes sure that the serial data from the LCD driver (uPD7225G) for the display is properly sent from the CPU. Input is inhibited when the BUSY signal is low, and permitted when the level is high.

(The CPU remains in the output standby mode when there is no BUSY signal. The LOGIC UNIT will not operate if there is a malfunction in this line.)

(6) 10Hz DATA input (column 4 → D0, D1, D2, D3)

The pulses of the MAIN DIAL are counted by the TC4510BP (or equivalent) BCD UP/DOWN counter and the output of 01 through 04 is D/A converted between a frequency of 0 and 90Hz (not displayed on the LCD) for control of the L0 crystal oscillator. (Refer to Fig. 11, page 5-10).

The output (01 through 04) of the TC4510BP is used as the frequency data for the VFO and MEMORY, and is written into the internal frequency data area of the CPU.

When the unit is switched to VFO or MEMO-CH, a dummy dial pulse is passed into the TC-4510BP from port 11 (pin 14) of the CPU, to restore 01 through 04 to its original D/A data.

SECTION 6 VOLTAGE/CIRCUIT DIAGRAMS

6 - 1 FRONT UNIT AND WIRING DIAGRAM

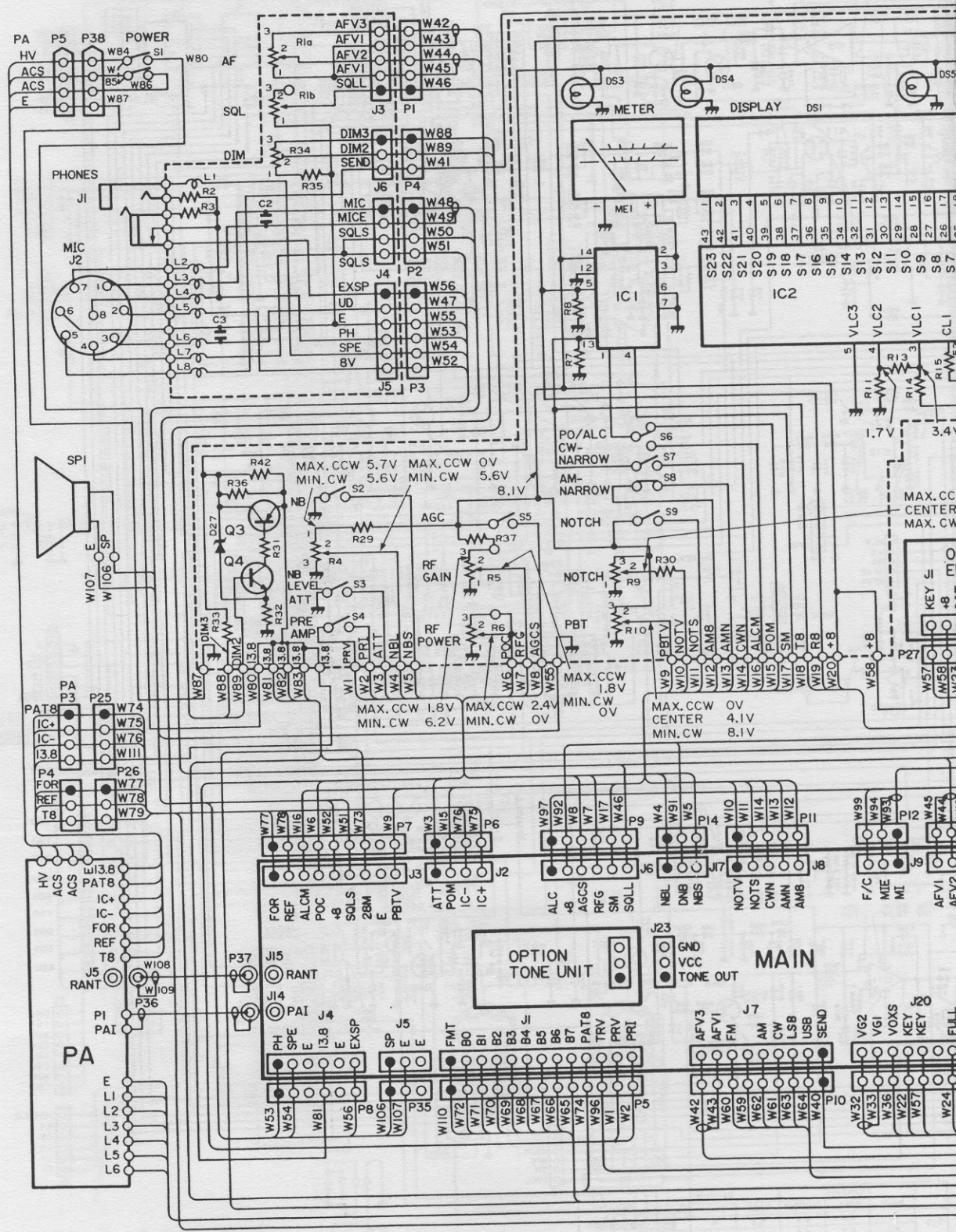

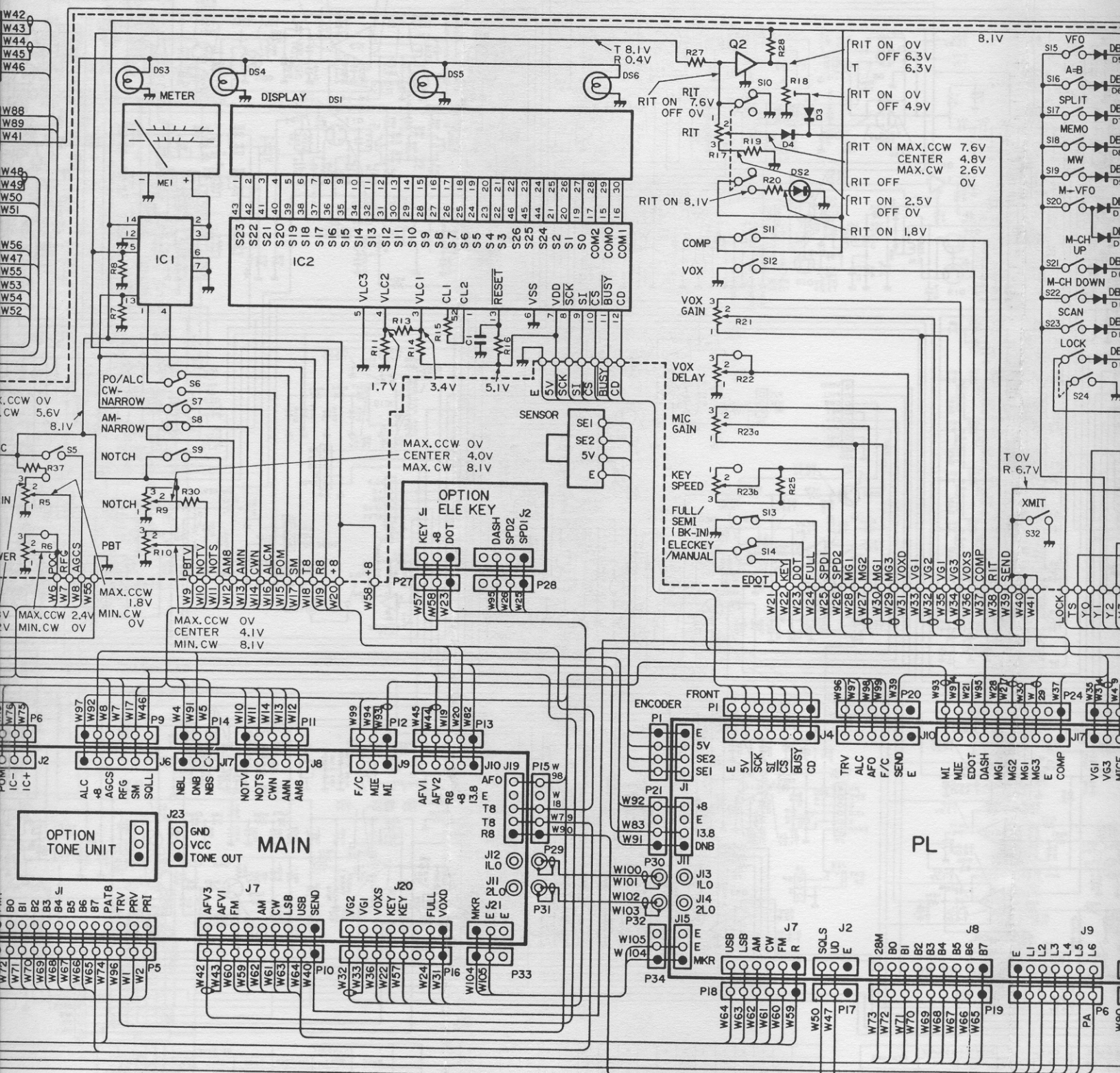

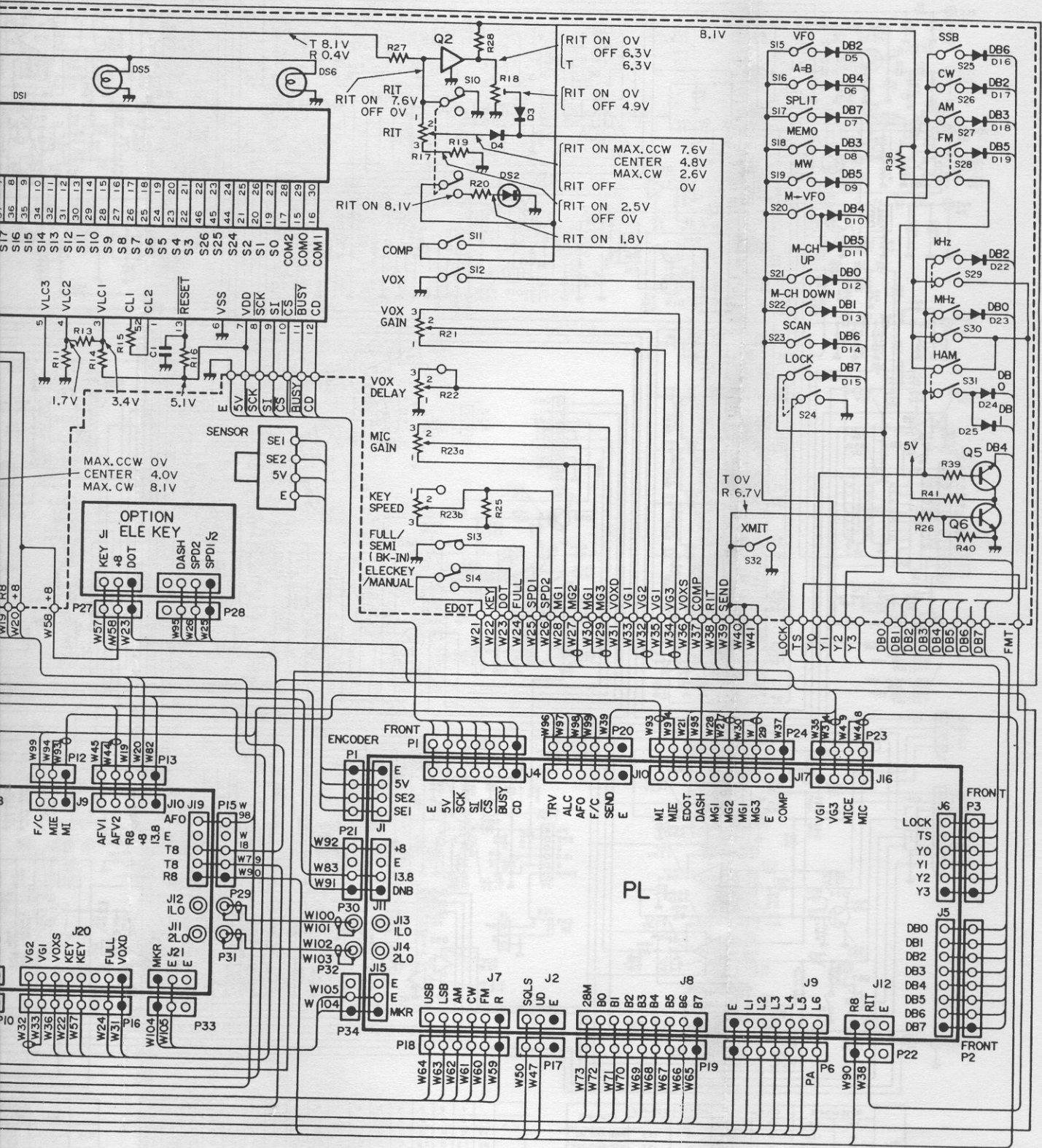

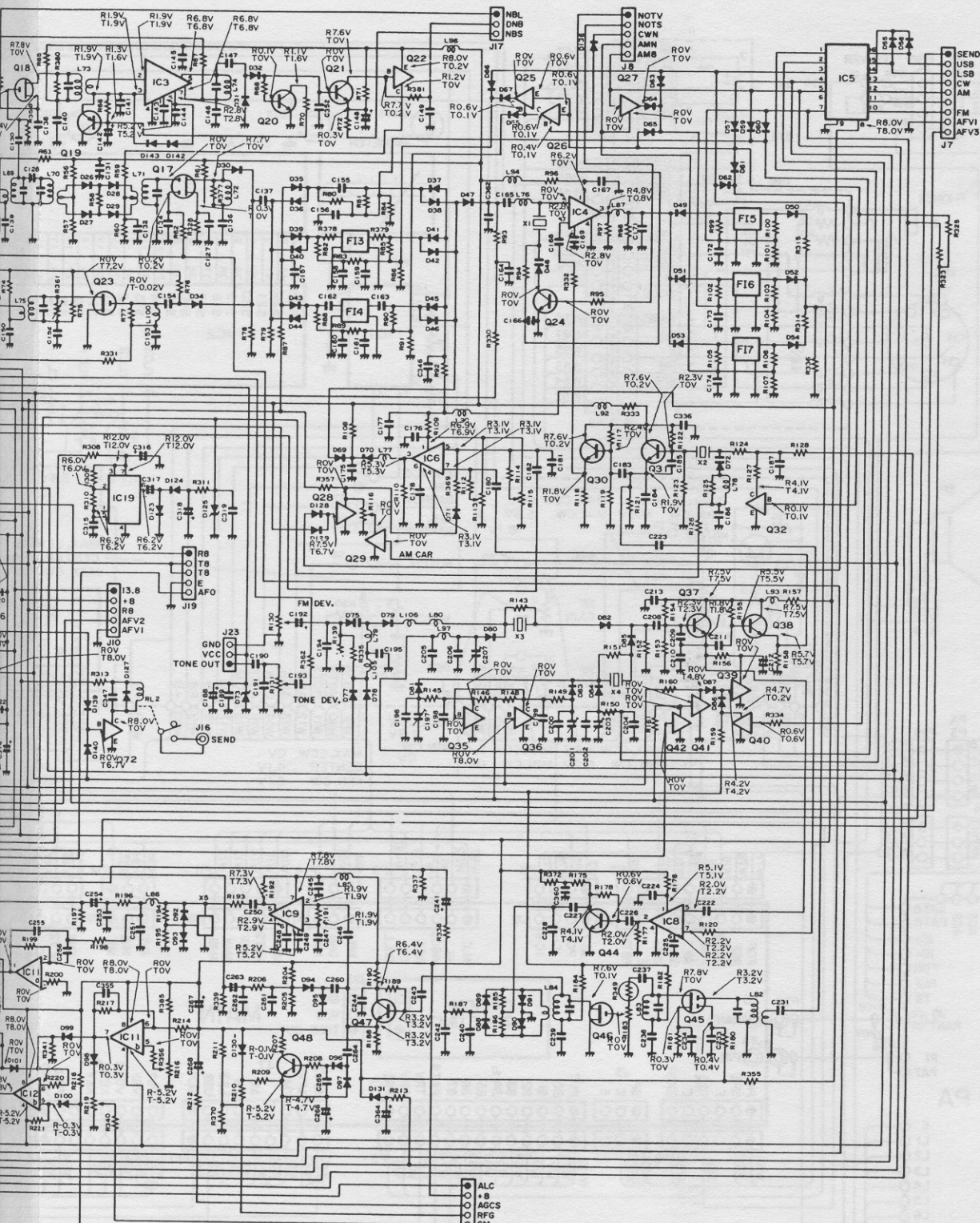

- NBL
- DNB
- NBS

- NOTV
- NOTS
- CWN
- AMN
- AMB

- SEND
- USB
- LSB
- CW
- AM
- FM
- AFV1
- AFV3

- ALC
- +B
- AGCS
- RFG
- SM
- SGL

	TRANSMIT			RECEIVE			REMARKS
	BASE	COLL	EMITTER	BASE	COLL	EMITTER	
Q25	2.1	6.4	6.5	6.4	0	6.5	CW NAR ON
	2.1	6.5	6.5	2.1	6.5	6.5	CW NAR OFF
Q26	6.2	2.1	6.5	0.6	6.5	6.5	CW NAR ON
	6.2	2.1	6.5	6.2	2.1	6.5	CW NAR OFF
Q27	1.0	7.2	7.2	1.0	7.2	7.2	AM NAR ON
	7.2	0	7.2	7.2	0	7.2	AM NAR OFF



	BASE OF GATE		COLL. OF DRAIN		EMITTER OF SOURCE		REMARKS
	TX	RX	TX	RX	TX	RX	
D11	0	13.0	0	0	13.5	0	PRE AMP ON
	0	0	0	0	13.5	0	PRE AMP OFF
	0	0	0	0	1.3	0	PRE AMP ON
D12	0	0	0	0	0	0	PRE AMP OFF
	0	0	0	0	1.3	0	PRE AMP ON
D13	0	0	0	0	0	0	PRE AMP OFF

		TUNING INDICATOR															
		1	2	3	4	5	6	7	8	9	10	11	12	13	14	15	16
IC-2	RX	0	0	0	0	13.0	0	0	0	13.8	GND	0	0	4.3	0	0	0
	TX	0	0	0	0	0	0	0	0	0	0	0	0	4.3	0	0	4.2
IC-5	RX	7.3	0	7.2	0	0	0	0	0	8.0	GND	0	0	0	0	3.7	0
	TX	7.2	0	7.2	0	0	0	0	0	8.0	GND	0	0	0	0	3.7	0
IC-13	RX	0	0	0	0	0	0	0	0	GND	0	0	0	6.7	6.7	8.0	0
	TX	0	0	0	0	0	0	0	0	GND	0	0	0	1.2	1.2	8.0	0

	TRANSMIT			RECEIVE			REMARKS
	BASE	COLL.	EMITTER	BASE	COLL.	EMITTER	
Q25	2.1	6.4	6.5	6.4	0	6.5	CW NAR ON
	2.1	6.5	6.5	2.1	6.5	6.5	CW NAR OFF
	6.2	2.1	6.5	6.2	2.1	6.5	CW NAR OFF
Q26	6.2	2.1	6.5	6.0	7.2	7.2	AM NAR ON
	1.0	7.2	7.2	1.0	7.2	7.2	AM NAR OFF
Q27	7.2	0	7.2	7.2	0	7.2	

ALC
+8
AGCS
RFG
SM
SOLL

6-2 MAIN UNIT

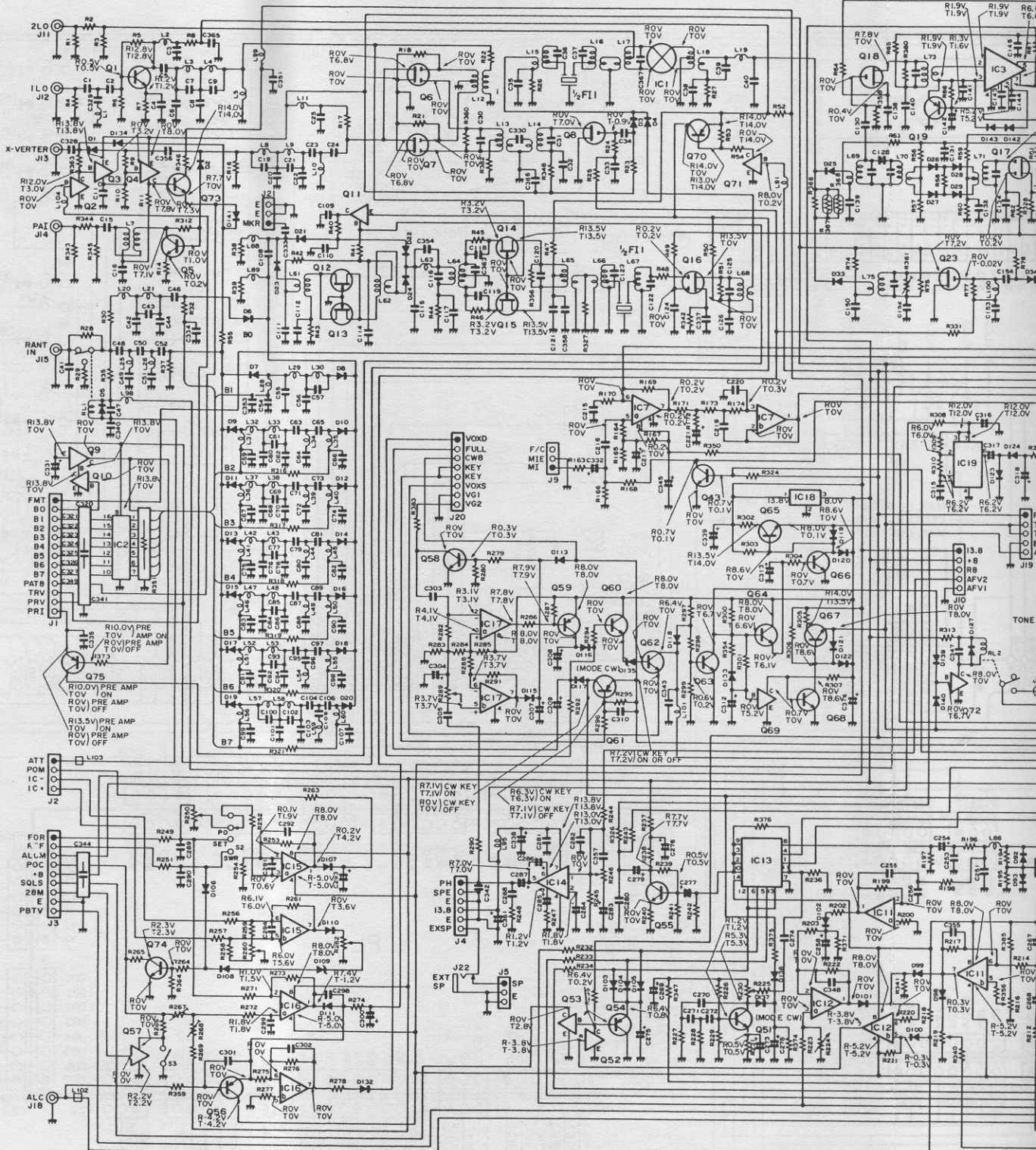

	BASE or GATE		COLL or DRAIN		EMITTER or SOURCE		REMARKS
	TX	RX	TX	RX	TX	RX	
Q11	0	13.0	0	0	13.5	0	PRE AMP ON
	0	0	0	0	13.5	0	PRE AMP OFF
Q12	0	0	0	12.5	0	1.3	PRE AMP ON
	0	0	0	0	0	0	PRE AMP OFF
Q13	0	0	0	12.5	0	1.3	PRE AMP ON
	0	0	0	0	0	0	PRE AMP OFF

	1	2	3	4	5	6	7	8	9	10	11	12	13	14	15	16
IC-2	RX	0	0	0	13.0	0	0	13.8	GND	0	0	4.3	0	0	0	0
	TX	0	0	0	0	0	0	0	GND	0	0	4.3	0	0	0	0
IC-5	RX	7.3	0	7.2	0	0	0	8.0	GND	0	0	0	3.7	0	4.2	
	TX	7.2	0	7.2	0	0	0	8.0	GND	0	0	0	3.7	0	4.2	
IC-13	RX	0	0	0	0	0	0	GND	0	0	6.7	6.7	8.0			
	TX	0	0	0	0	0	0	GND	0	0	1.2	1.2	8.0			

	BASE	COLL
Q25	2.1	6.4
	2.1	6.5
Q26	6.2	2.1
	6.2	2.1
Q27	1.0	7.2
	7.2	0

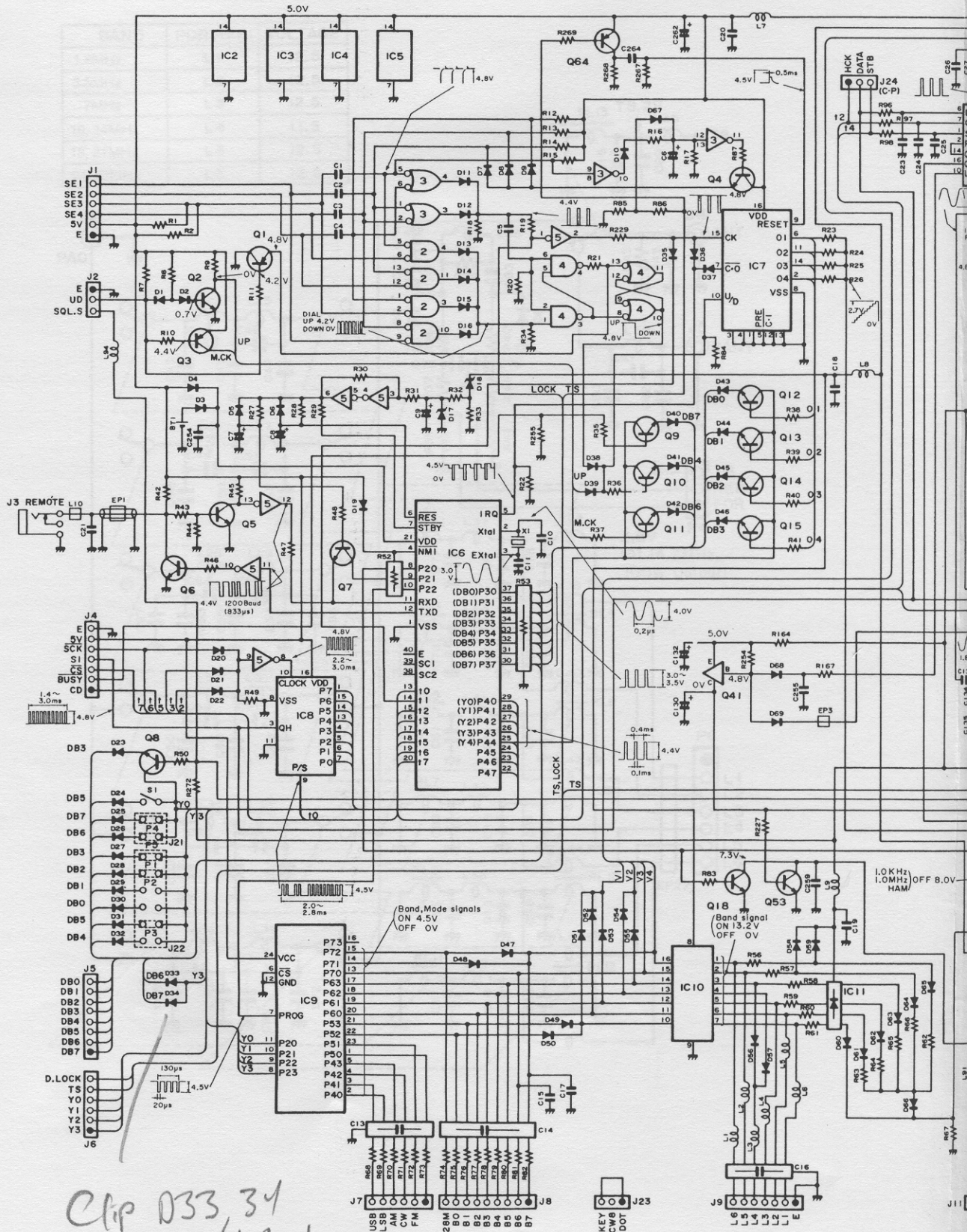

*Chip D33, 34
for out of Band
TX*

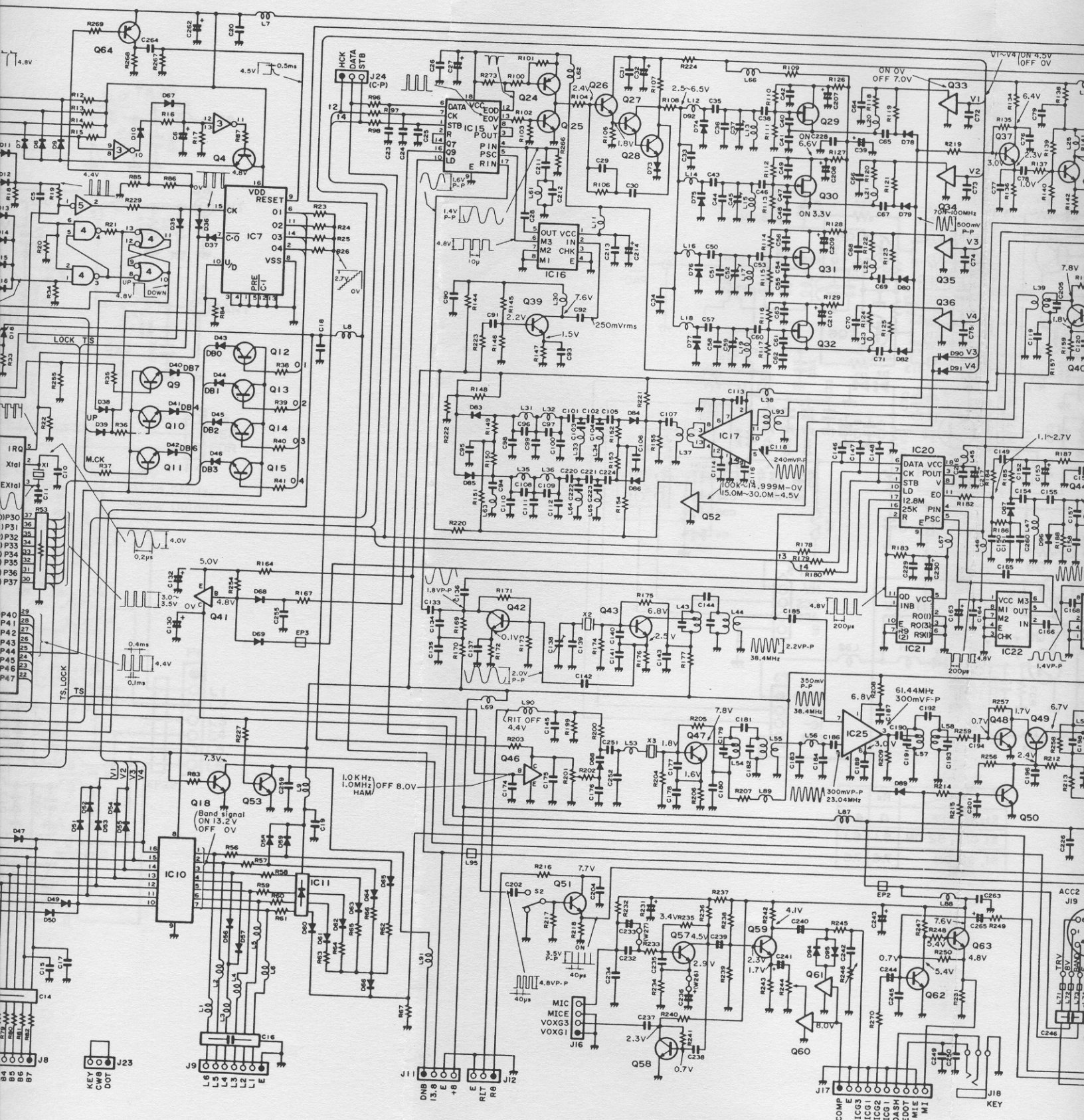

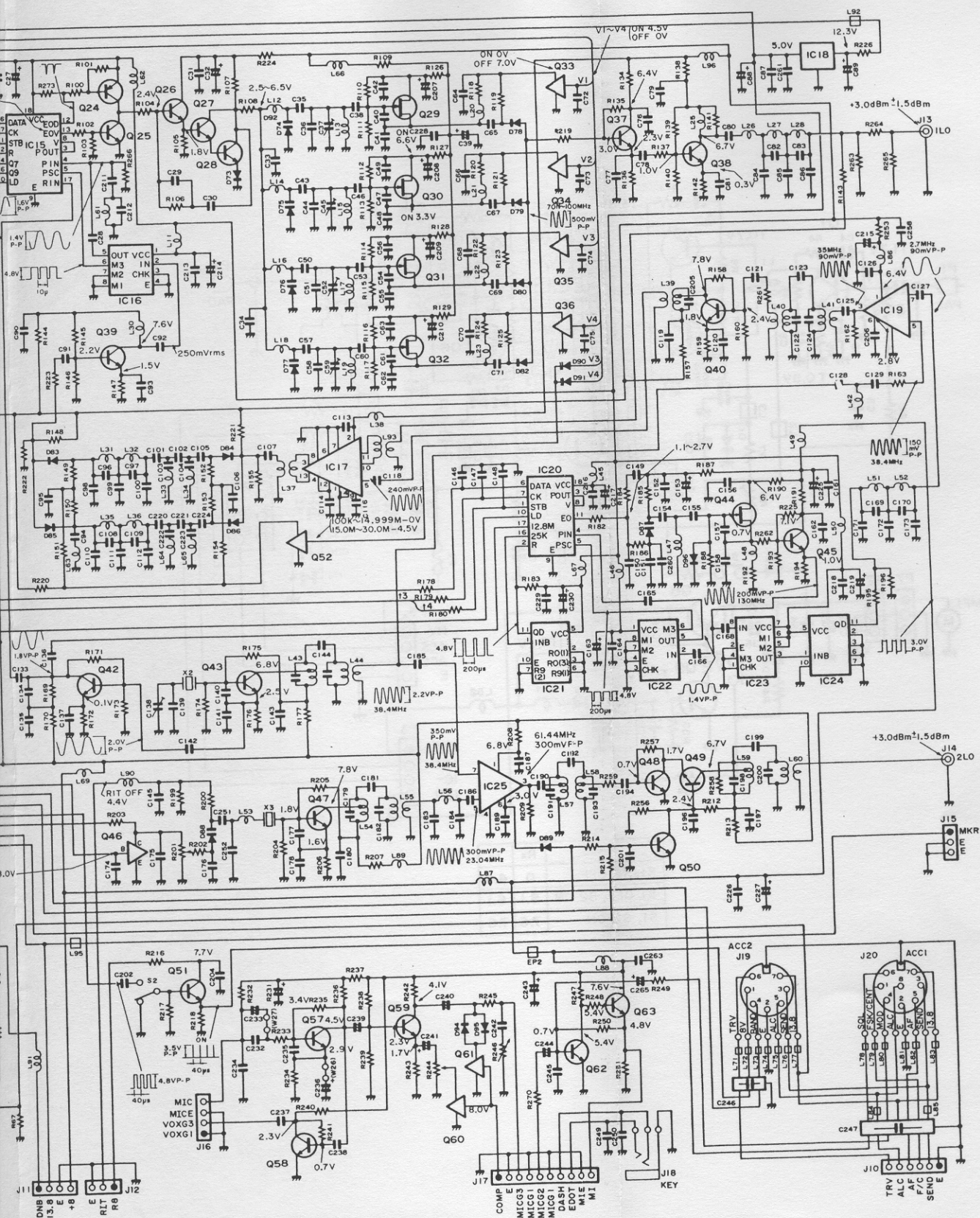

6 - 4 PA UNIT (POWER AMPLIFIER)

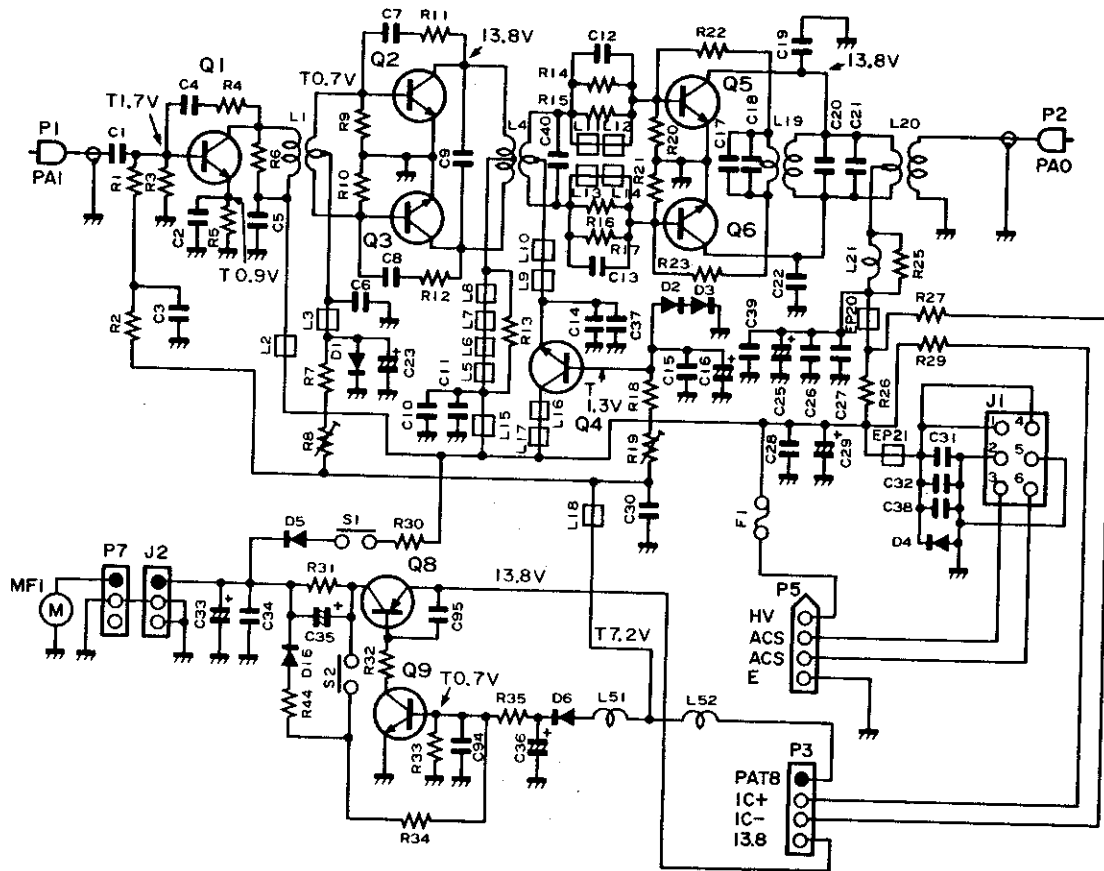

	Rx	Tx
S1, S2 OFF	0	4.4
S1 OFF, S2 ON	6.1	6.1
S1, S2 ON	7.6	7.6

6 - 5 PA UNIT (FILTER)

BAND	PORT(P6)	VOLTAGE
1.8MHz	L 1	12.5
3.5MHz	L 2	12.5
7MHz	L 3	12.5
10, 14MHz	L 4	11.5
18, 21MHz	L 5	12.5
24, 28MHz	L 6	12.5

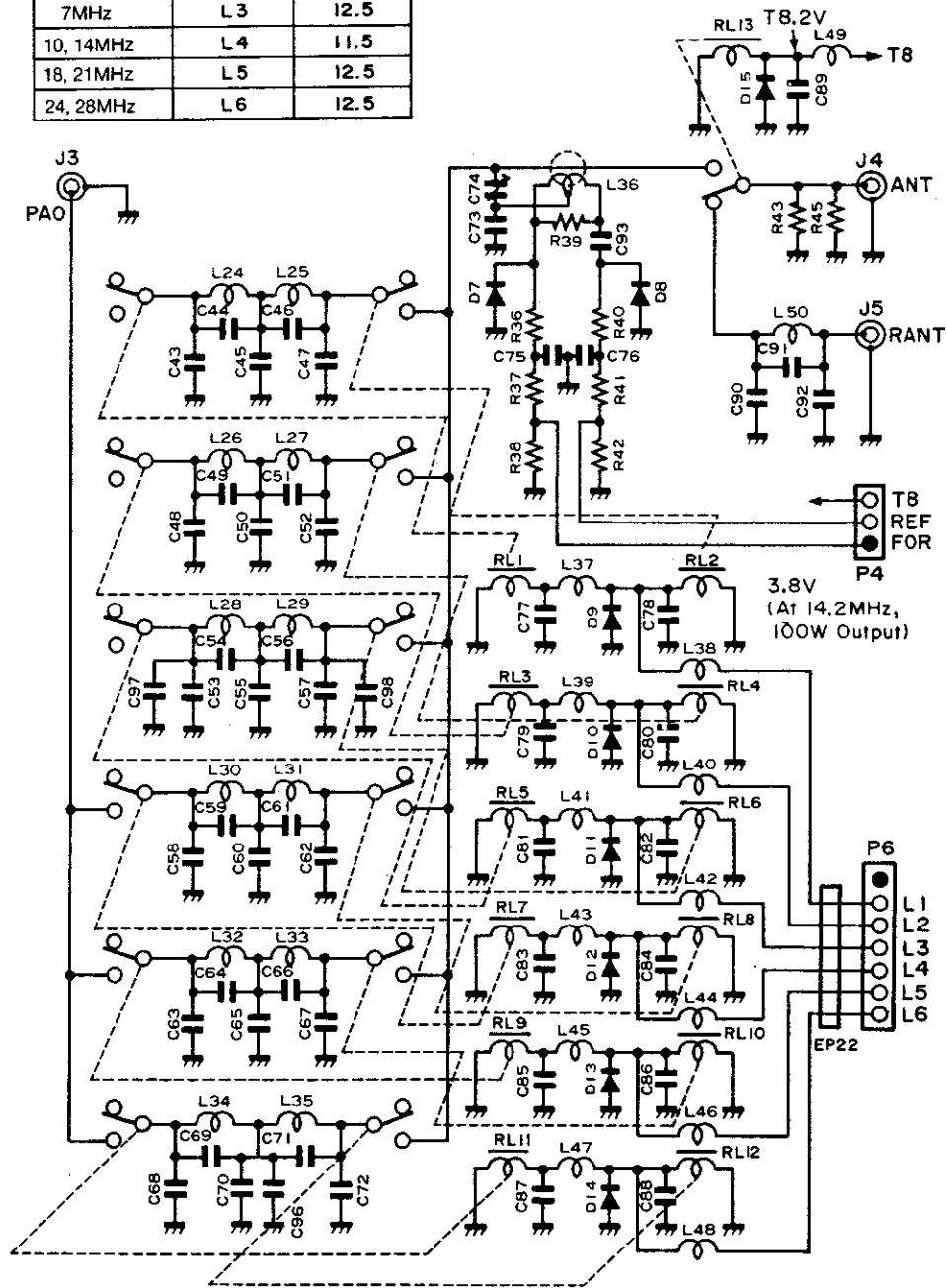

6 - 6 FRONT UNIT DIMMER CIRCUIT

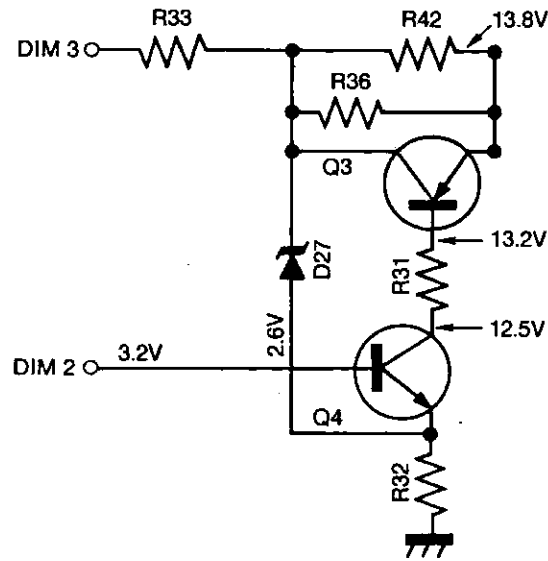

6 - 7 SENSOR UNIT

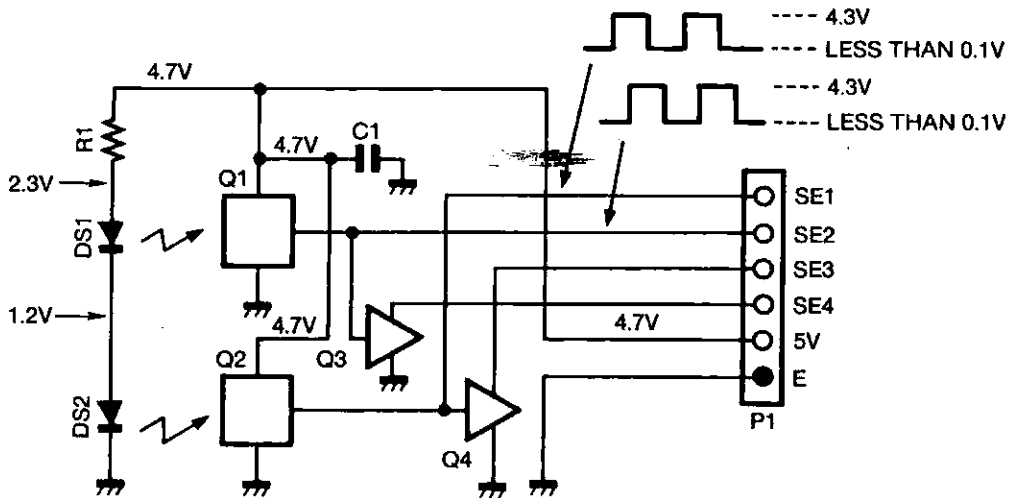

SECTION 7 MAINTENANCE AND ADJUSTMENT

7 - 1 PREPARATION BEFORE SERVICING

1. Detach the power cord and turn off the power switch before performing any work on the transceiver.
2. Do not short circuit components while making adjustments.
3. Use an insulated tuning tool for all adjustments.
4. Do not force any of the variable components. Tune them slowly and smoothly.
5. Follow the instructions exactly. If an indicated result is not obtained, repeat the instruction until the correct result is obtained.
6. Check the condition of connectors, solder joints and screws when adjustments are complete. Confirm that components do not touch each other.
7. Confirm defective operation of the radio first when checking an out-of-service unit. Verify that external sources do not cause the problem.
8. Use the correct tools and test equipment.
9. Remove the transceiver case as shown in SECTION 10-2.
10. Attach a 13.8 volt DC external power source to the power supply connector. Be sure to check the polarity.
11. For transmission problems, attach a dummy load to the antenna connector. For reception problems, attach an antenna or signal generator to the antenna connector. Do not transmit into the signal generator.
12. Recheck for the suspected malfunction with the power switch on.
13. Check the defective circuit. Measure the DC voltages of the collector, base and emitter of each transistor.

7 - 2 GENERAL ADJUSTMENT

TEST INSTRUMENTS REQUIRED	MEASUREMENT CONNECTION LOCATION
<p>(1) VOLTAGE REGULATED POWER SUPPLY</p> <ul style="list-style-type: none"> • Output voltage : 13.8V DC \pm15% • Current capacity : 3A or more <p>(2) FREQUENCY COUNTER</p> <ul style="list-style-type: none"> • Frequency minimum : 150MHz • Frequency accuracy : 1ppm or better • Sensitivity : 100mV or better 	

ADJUSTMENT	ADJUSTMENT CONDITIONS	MEASUREMENT		VALUE	ADJUSTMENT POINT		
		UNIT	LOCATION		UNIT	ADJUST	
BFO FREQUENCY	<ul style="list-style-type: none"> • Display freq.: 14.1000MHz • Plug the CW keyer to [KEY JACK]. • Set the [ELEC KEY] SWITCH to MANUAL position. 	MAIN	Connect frequency counter to R158.	Note: [VOX] SWITCH must be in OFF position.	9.01300MHz	MAIN	C207
	<ul style="list-style-type: none"> • Mode: USB • Receive mode 				9.01000MHz		C203
	<ul style="list-style-type: none"> • Mode: LSB • Receive mode 				9.00980MHz		C201
	<ul style="list-style-type: none"> • Mode: CW • Receive mode 				9.01060MHz		C197
	<ul style="list-style-type: none"> • Mode: CW • Transmit and key down. • Output power must be at minimum. 				9.01150MHz		L79
	<ul style="list-style-type: none"> • Mode: AM or FM • Transmit mode 						
PBT	<ul style="list-style-type: none"> • Mode: LSB or USB • Receive mode • [PBT] CONTROL: Center 	MAIN	Connect frequency counter to R332.	9.46650MHz	MAIN	L78	
	<ul style="list-style-type: none"> • Mode: CW • Receive mode • [PBT] CONTROL: Center 			Within 9.46560MHz \pm 500Hz		Verify	

MAIN UNIT

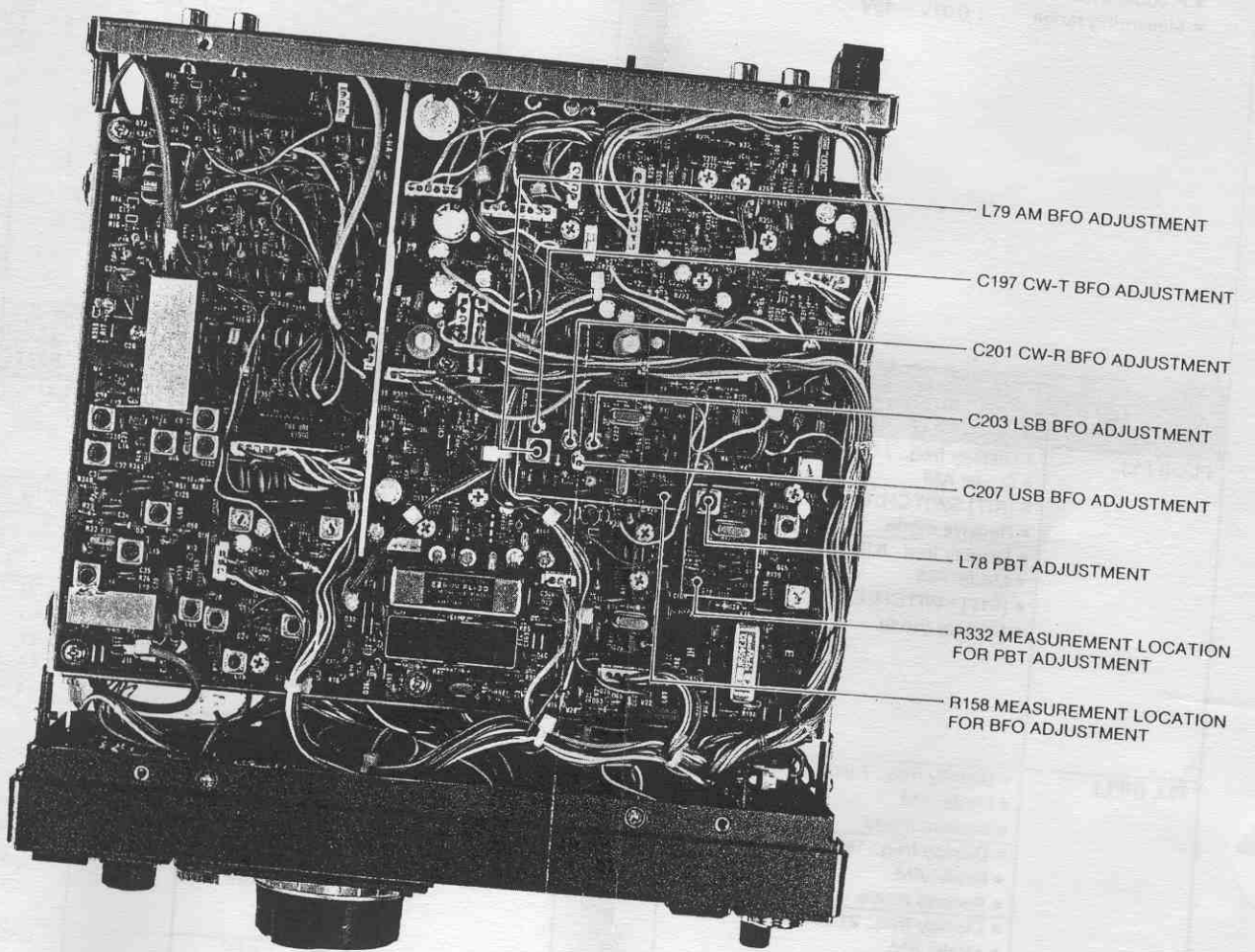

L79 AM BFO ADJUSTMENT

C197 CW-T BFO ADJUSTMENT

C201 CW-R BFO ADJUSTMENT

C203 LSB BFO ADJUSTMENT

C207 USB BFO ADJUSTMENT

L78 PBT ADJUSTMENT

R332 MEASUREMENT LOCATION
FOR PBT ADJUSTMENT

R158 MEASUREMENT LOCATION
FOR BFO ADJUSTMENT

7-3 PL ADJUSTMENT

TEST INSTRUMENTS REQUIRED		MEASUREMENT CONNECTION LOCATION				
(1) VOLTAGE REGULATED POWER SUPPLY • Output voltage : 13.8V DC \pm 15% • Current capacity : 3A or more (2) FREQUENCY COUNTER • Frequency minimum : 150MHz • Frequency accuracy : 1ppm or better • Sensitivity : 100mV or better (3) VOLTMETER • Input impedance : 50k Ω /V DC or better (4) RF VOLTMETER • Frequency minimum : 80MHz • Measuring range : 0.01V ~ 10V						
ADJUSTMENT	ADJUSTMENT CONDITIONS	MEASUREMENT		VALUE	ADJUSTMENT POINT	
		UNIT	LOCATION		UNIT	ADJUST
PLL (LPL)	<ul style="list-style-type: none"> • Display freq.: 7.9999MHz • Mode: AM • [RIT] SWITCH: OFF • Receive mode 	PL	Connect voltmeter to R182.	1.2V	PL	L47
				2.5V		Verify
	<ul style="list-style-type: none"> • Display freq.: 8.0000MHz • Mode: AM • [RIT] SWITCH: OFF • Receive mode 	Connect RF voltmeter to pin 5 of IC17.	Maximum (Should be at least 40mV rms)	L39 L40 L41 L43 L44		
PLL (HPL)	<ul style="list-style-type: none"> • Display freq.: 7.9999MHz • Mode: AM • Receive mode • Display freq.: 14.9999MHz • Mode: AM • Receive mode • Display freq.: 21.9999MHz • Mode: AM • Receive mode • Display freq.: 30.0000MHz • Mode: AM • Receive mode 	PL	Connect voltmeter to R108.	6.5V	PL	C37
				6.5V		C45
				6.5V		C52
				6.5V		C59
PLL (1st LO)	<ul style="list-style-type: none"> • Display freq.: 30.0000MHz • Mode: AM • Receive mode 	PL	Connect frequency counter to J13.	100.45150 MHz	PL	C138
				70.55150 MHz		Verify
	<ul style="list-style-type: none"> • Display freq.: 0.1000MHz • Mode: AM • Receive mode 	Connect RF voltmeter to J13.	More than 400mV rms	Verify		

PL UNIT

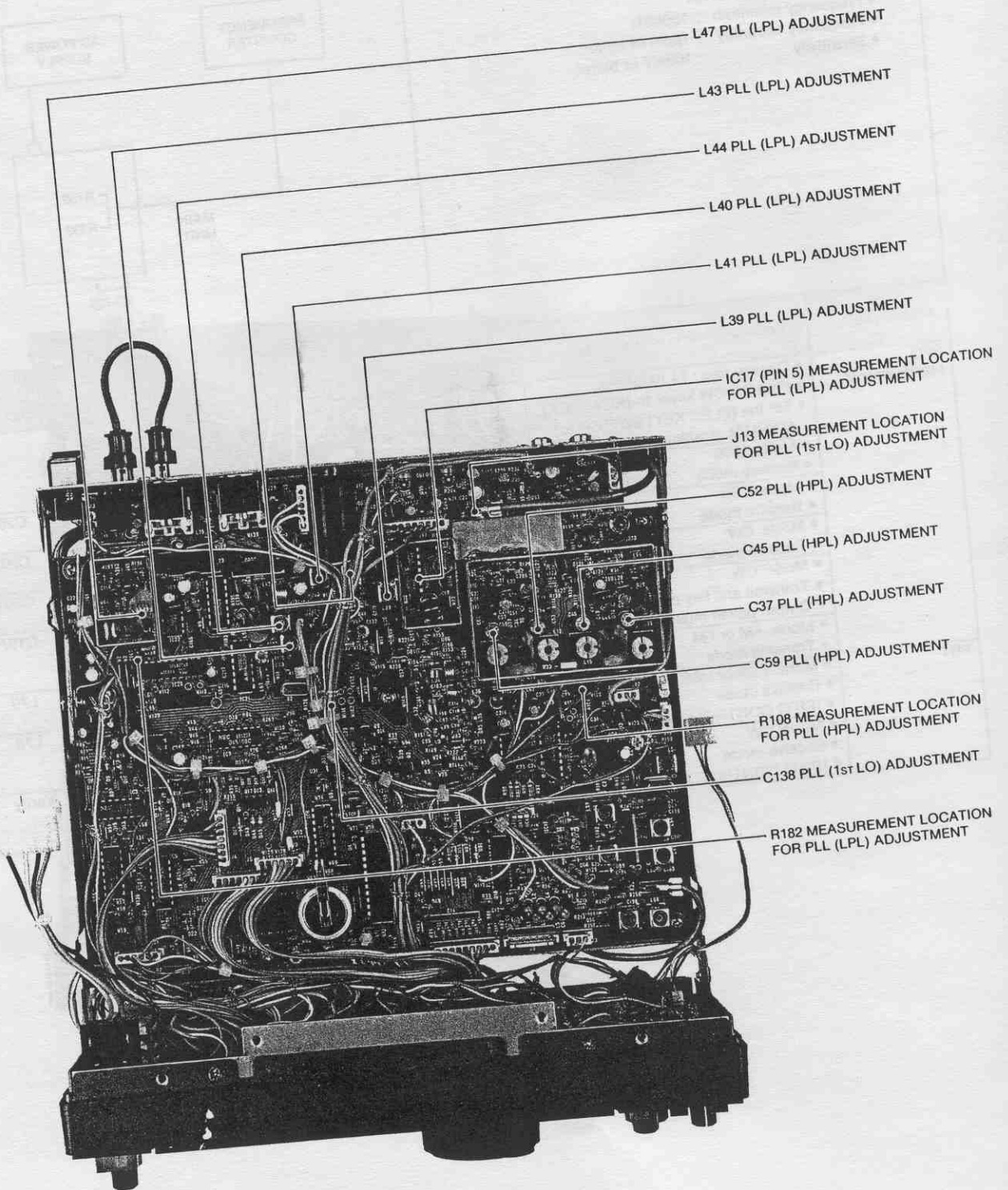

PL ADJUSTMENT

ADJUSTMENT	ADJUSTMENT CONDITIONS	MEASUREMENT		VALUE	ADJUSTMENT POINT	
		UNIT	LOCATION		UNIT	ADJUST
PLL (2ND LO)	<ul style="list-style-type: none"> • Display freq.: 14.1000MHz • Mode: AM • Receive mode 	PL	Connect RF voltmeter to J14.	Maximum (Shou'd be at least 700mV rms)	PL	L54
	<ul style="list-style-type: none"> • Display freq.: 14.1000MHz • Mode: AM • Receive mode • [RIT] SWITCH: ON 		Connect frequency counter to J14.			61.44000MHz
			<ul style="list-style-type: none"> • Display freq.: 14.9000MHz • Mode: AM • Receive mode • [RIT] SWITCH: OFF 			
PLL (RIT)	<ul style="list-style-type: none"> • Mode: AM • [kHz] SWITCH: Out position • [RIT] SWITCH: ON • [RIT] CONTROL: Max. C.W. • Receive mode • Rotate the TUNING CONTROL between 14.999.9 and 15.000.0MHz. 	PL	Connect frequency counter to J14.	100Hz of frequency difference	PL	R201

FRONT UNIT

R17 PLL (2nd LO)
ADJUSTMENT

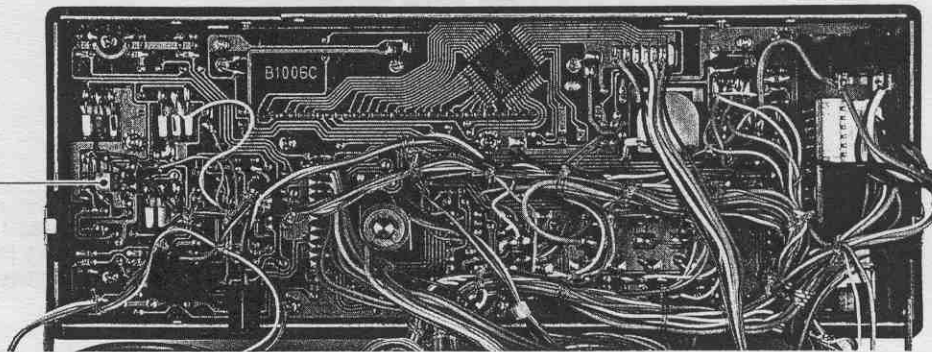

PL UNIT

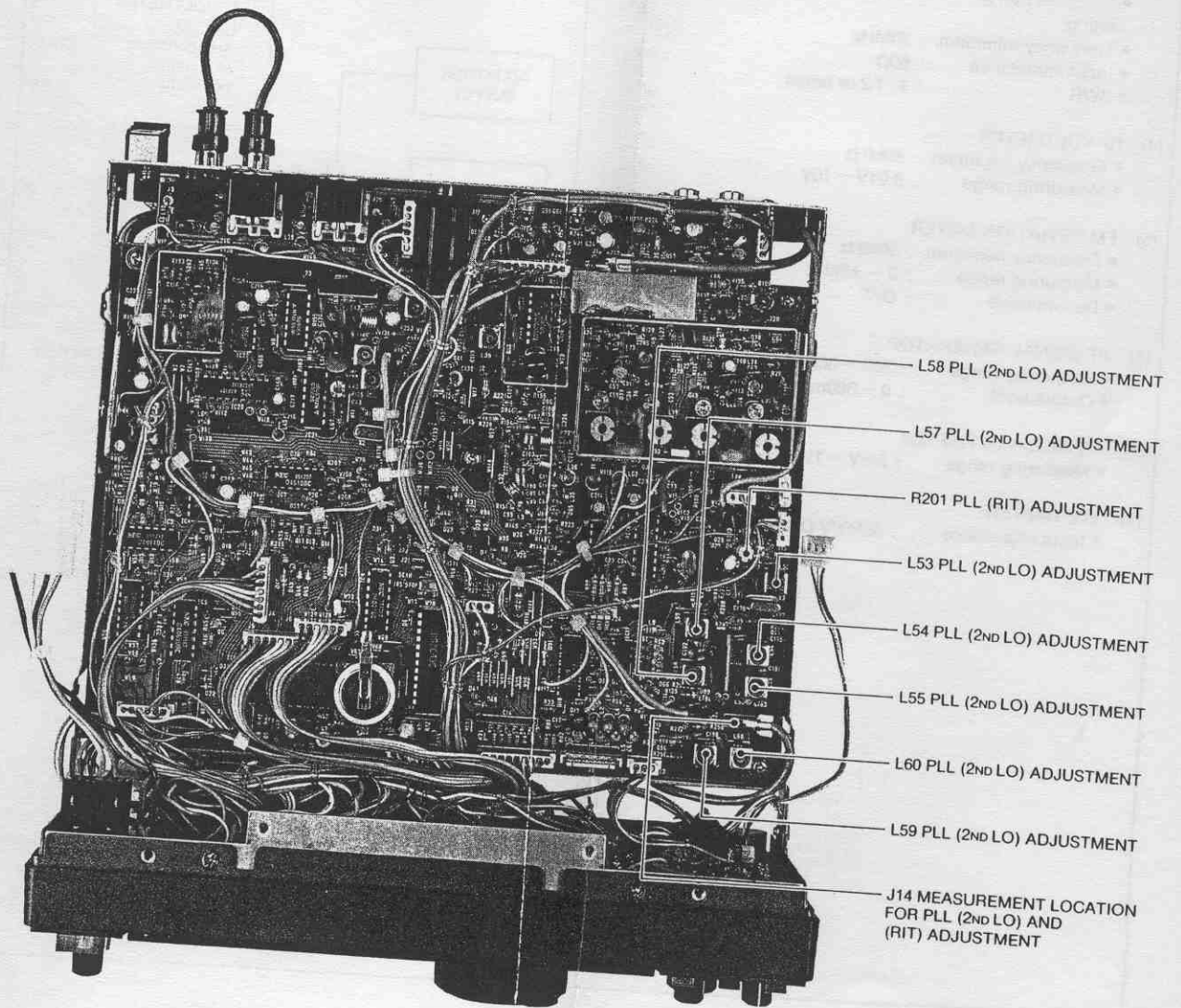

7-4 TRANSMITTER ADJUSTMENT

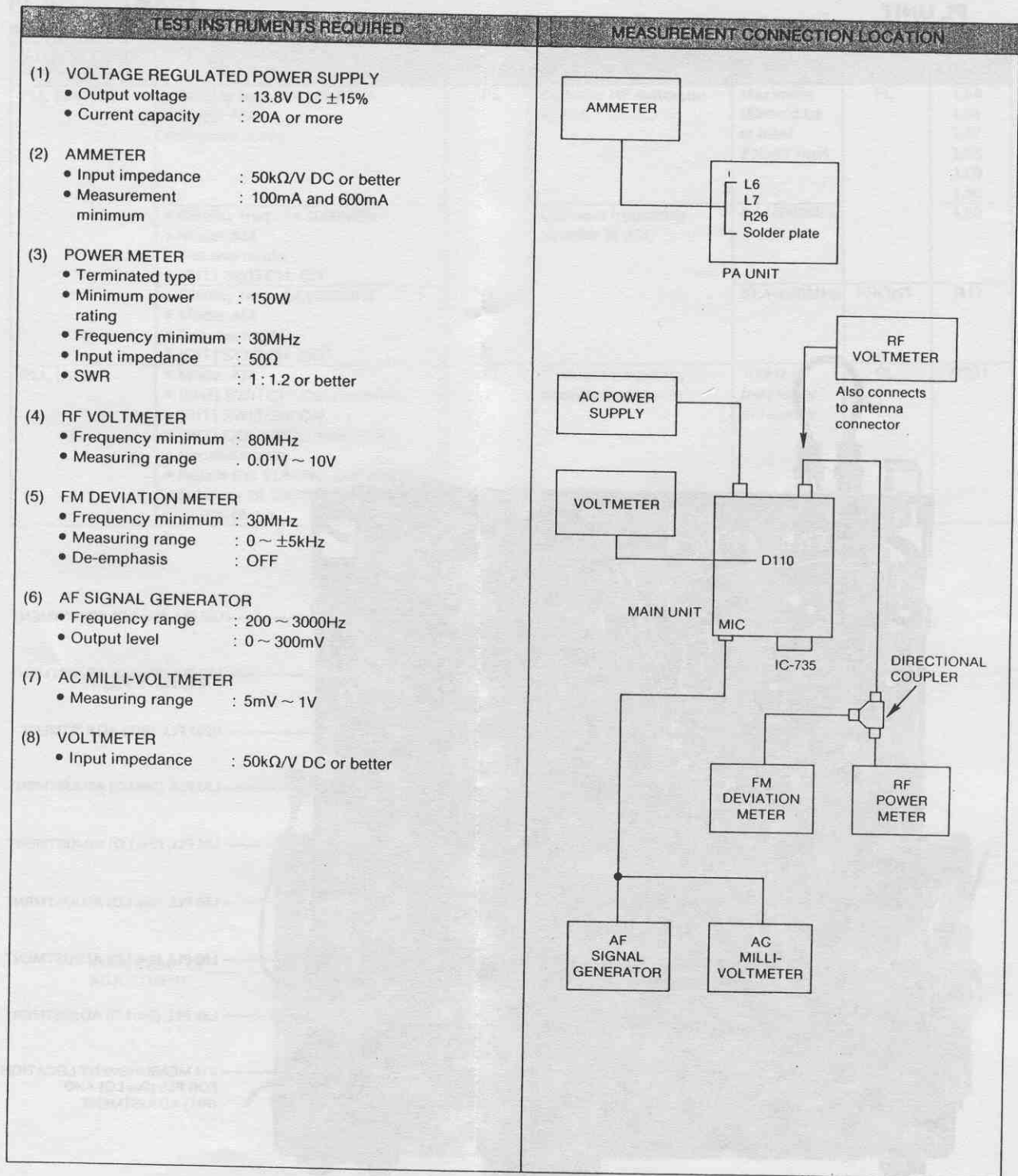

TRANSMITTER ADJUSTMENT

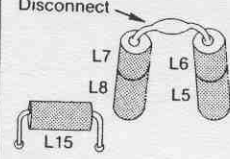
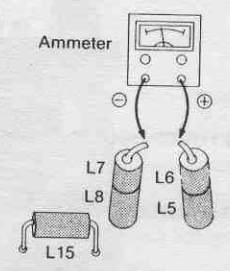
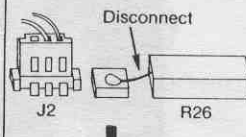
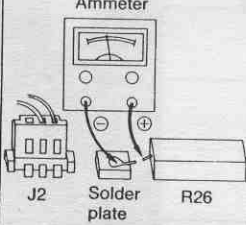
ADJUSTMENT	ADJUSTMENT CONDITIONS	MEASUREMENT		VALUE	ADJUSTMENT POINT	
		UNIT	LOCATION		UNIT	ADJUST
IDLING CURRENT (DRIVER TR)	<ul style="list-style-type: none"> • Display freq.: 14.10000MHz • Mode: USB • Disconnect the connection between L6 and L7. • Apply no signal to the MIC CONNECTOR. • Transmit mode <p>Note: Resolder after making adjustment.</p>	PA	Connect ammeter between L6 and L7. Disconnect  	100mA	PA	R8
IDLING CURRENT (FINAL TR)	<ul style="list-style-type: none"> • Display freq.: 14.1000MHz • Mode: USB • Disconnect the connection between R26 and EP20. • Apply no signal to the MIC CONNECTOR. • Transmit mode <p>Note: Resolder after the adjustment.</p>		Connect ammeter between R26 and the solder plate on the board. Disconnect  	600mA		R19
OUTPUT POWER	<ul style="list-style-type: none"> • Display freq.: 14.10000MHz • Mode: USB • [COMP] SWITCH: OFF • [RF POWER] CONTROL: Maximum • Connect audio signal generator to the MIC CONNECTOR. • Transmit mode 					
	<ul style="list-style-type: none"> • Set R361 on MAIN board to maximum clockwise. • Apply 1.5kHz/1mV to the MIC CONNECTOR. • Set the RF output power to 40W with the [MIC GAIN] CONTROL. • Apply 1.5kHz/1mV to the MIC CONNECTOR. • Set the [MIC GAIN] CONTROL to maximum position. 	ANTE-NNA CONNECTOR	Connect RF power meter to antenna connector.	Maximum RF output power	MAIN	L13 L14 L75 (p. 7-7)
				50W		R361 (p. 7-7)

PA UNIT

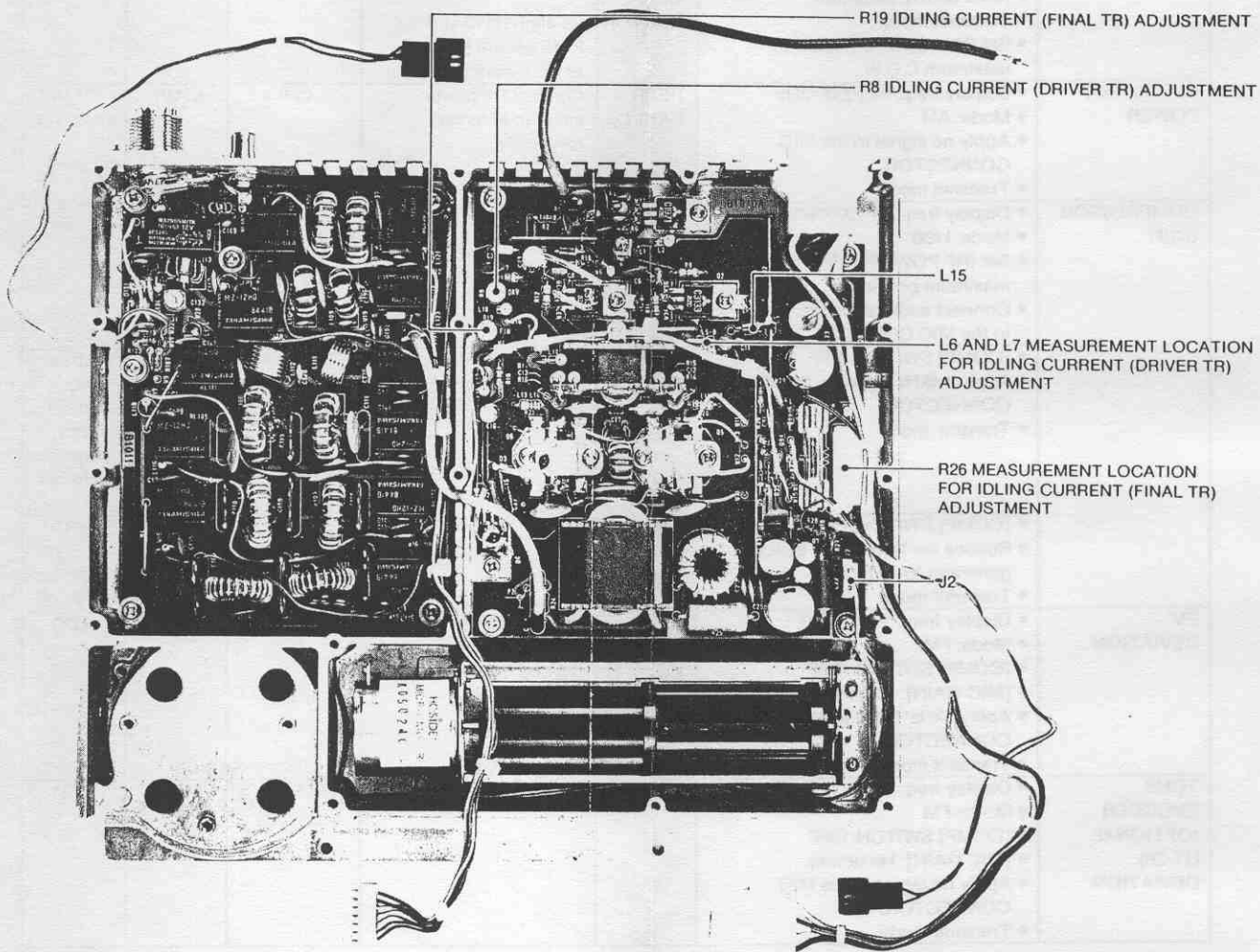

TRANSMITTER ADJUSTMENT

ADJUSTMENT	ADJUSTMENT CONDITIONS	MEASUREMENT		VALUE	ADJUSTMENT POINT	
		UNIT	LOCATION		UNIT	ADJUST
SETTING OUTPUT POWER	<ul style="list-style-type: none"> • Display freq.: 14.10000MHz • Mode: FM • Transmit mode 	REAR PANEL	Connect RF power meter to antenna connector.	100W	MAIN	R268
	<ul style="list-style-type: none"> • Set S3 on the MAIN board to 100W position. • Set [RF POWER] CONTROL to maximum position. 			10W		R267
AM CARRIER LEAK POWER	<ul style="list-style-type: none"> • Display freq.: 14.10000MHz • Mode: AM • [MIC GAIN]: Minimum • Transmit mode • Set R116 on MAIN board for maximum C.C.W.. 	ANTE- NNA CON- NECTOR	Connect RF voltmeter to antenna connector. Re-align R113 and R115 several times as necessary.	Minimum	MAIN	R113 R115
AM OUTPUT POWER	<ul style="list-style-type: none"> • Display freq.: 14.10000MHz • Mode: AM • Apply no signal to the MIC CONNECTOR. • Transmit mode 	REAR PANEL	Connect RF power meter to antenna connector.	40W	MAIN	R116 (p. 7—8)
COMPRESSOR GAIN	<ul style="list-style-type: none"> • Display freq.: 14.10000MHz • Mode: USB • Set [RF POWER] CONTROL to maximum position. • Connect audio signal generator to the MIC CONNECTOR. 	REAR PANEL	Connect RF power meter to antenna connector.	50W	Audio genera- tor	Output level control of the audio generator
	<ul style="list-style-type: none"> • [COMP] SWITCH: OFF • Apply 1.5kHz signal to the MIC CONNECTOR. • Transm. mode 			50W	REAR PANEL	R246 (COMP LEVEL) (p. 7—8)
FM DEVIATION	<ul style="list-style-type: none"> • Display freq.: 14.10000MHz • Mode: FM • [COMP] SWITCH: OFF • [MIC GAIN]: Maximum • Apply 1kHz/10mV to MIC CONNECTOR. • Transmit mode 	REAR PANEL	Connect Deviation meter to antenna connector using appropriate attenuator if required.	±4.75kHz	MAIN	R130
TONE ENCODER (OPTIONAL UT-30) DEVIATION	<ul style="list-style-type: none"> • Display freq.: 14.10000MHz • Mode: FM • [COMP] SWITCH: OFF • [MIC GAIN]: Maximum • Apply no signal to the MIC CONNECTOR. • Transmit mode 			±0.5kHz	MAIN	R131

NOTE: C.C.W = Counterclockwise

MAIN UNIT

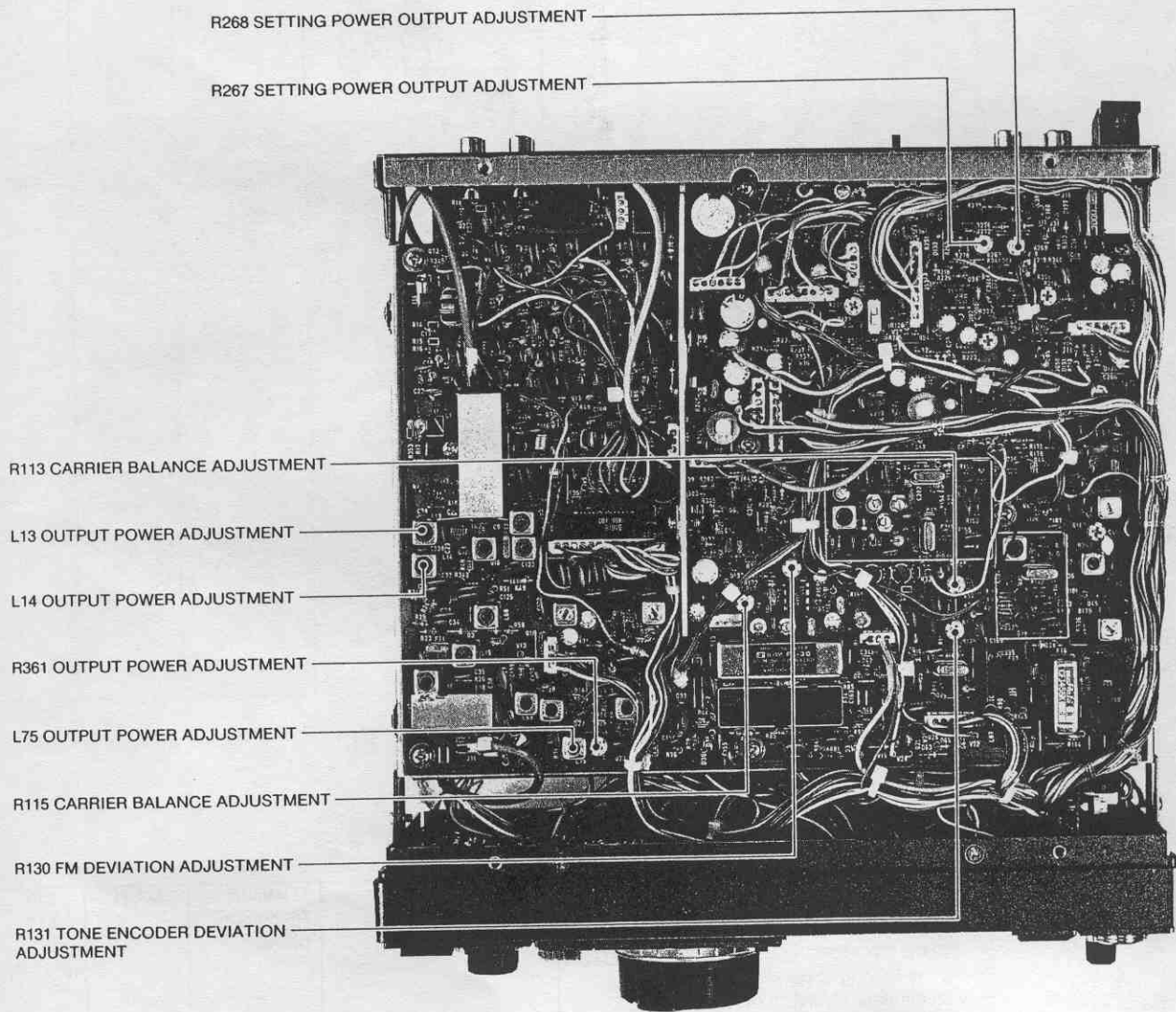

TRANSMITTER ADJUSTMENT

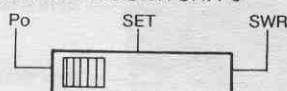
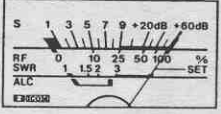
ADJUSTMENT	ADJUSTMENT CONDITIONS	MEASUREMENT		VALUE	ADJUSTMENT POINT	
		UNIT	LOCATION		UNIT	ADJUST
APC (Automatic Protection Circuit)	<ul style="list-style-type: none"> • Display freq.: 18.10000MHz • Mode: FM • [RF POWER]: Maximum 					
	<ul style="list-style-type: none"> • Receive mode 	MAIN	Connect voltmeter to cathode of D110.	At point where voltage begins to increase from OV.	MAIN	R260
	<ul style="list-style-type: none"> • Transmit mode 	REAR PANEL	Connect RF power meter to antenna connector.	At point where output power begins to dip.	MAIN	R262
CARRIER BALANCE	<ul style="list-style-type: none"> • Display freq.: 14.10000MHz • Mode: SSB • [MIC GAIN] CONTROL: Max. C.C.W. • [COMP] SWITCH: OFF • Transmit mode • Apply no signal to MIC CONNECTOR. 	REAR PANEL	Connect spectrum analyzer or RF voltmeter to antenna connector.	Minimum level (More than -50dB)	MAIN	R113 R115
RF METER	<ul style="list-style-type: none"> • Display freq.: 14.10000MHz • Mode: FM • [MIC GAIN]: Minimum • [RF POWER] Maximum • Transmit mode • REAR PANEL SWITCH: Po 	FRONT PANEL		100	MAIN	R250

REAR PANEL

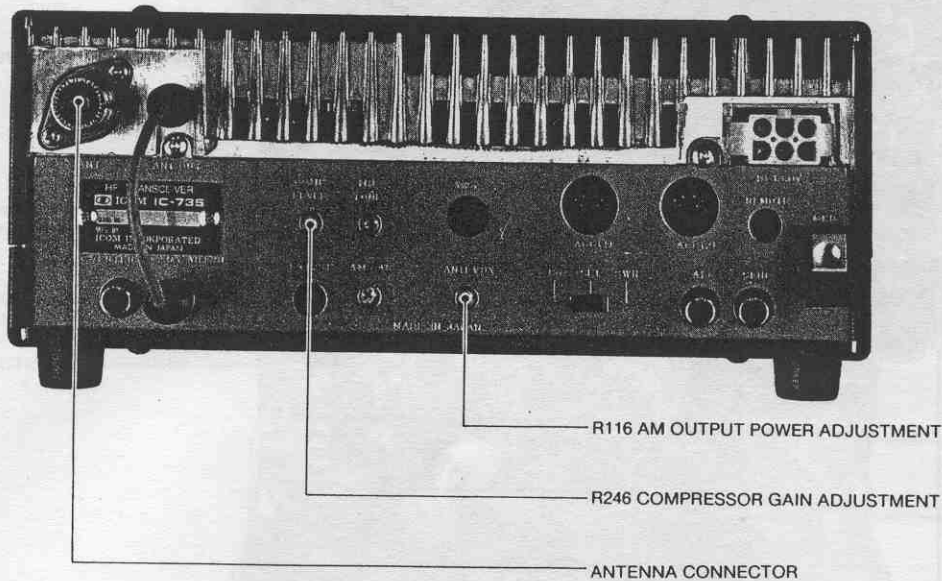

MAIN UNIT

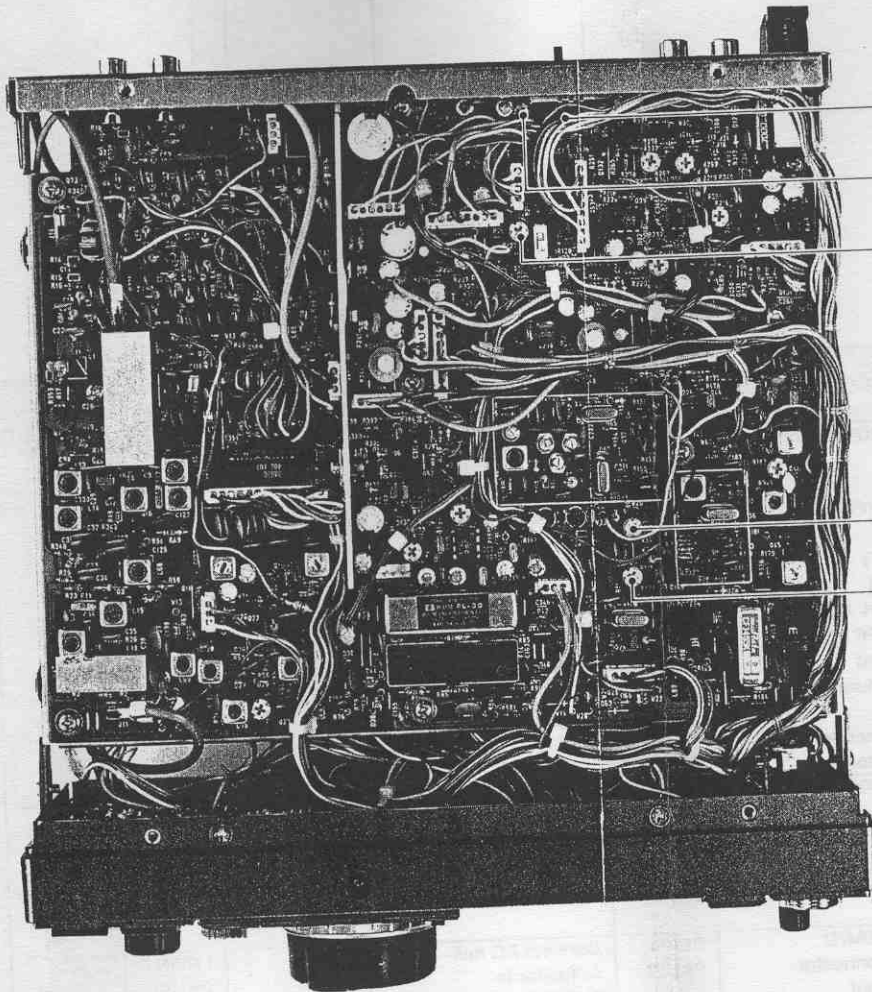

R250 RF METER ADJUSTMENT

R262 APC (TX) ADJUSTMENT

R260 APC (RX) ADJUSTMENT

R113 CARRIER BALANCE ADJUSTMENT

R115 CARRIER BALANCE ADJUSTMENT

7-5 RECEIVER ADJUSTMENT

TEST INSTRUMENTS REQUIRED	MEASUREMENT CONNECTION LOCATION
(1) VOLTAGE REGULATED POWER SUPPLY <ul style="list-style-type: none"> • Output voltage : 13.8V DC \pm15% • Current capacity : 3A or more (2) RF SIGNAL GENERATOR <ul style="list-style-type: none"> • Frequency range : 0.1~30MHz • Output level : 0.1μV ~ 100mV (3) AC MILLI-VOLTMETER <ul style="list-style-type: none"> • Measuring range : 5mV ~ 1V (4) EXTERNAL SPEAKER <ul style="list-style-type: none"> • Impedance : 8Ω 	

ADJUSTMENT	ADJUSTMENT CONDITIONS	MEASUREMENT		VALUE	ADJUSTMENT POINT	
		UNIT	LOCATION		UNIT	ADJUST
SENSITIVITY	<ul style="list-style-type: none"> • Display freq.: 14.10000MHz • Mode: USB • [PBT]: Center • [PRE AMP]: OFF (OUT) • [NB]: OFF (OUT) • [AGC]: Fast (OUT) • [ATT]: OFF (OUT) • [NOTCH] SWITCH: OFF (OUT) • [RIT] SWITCH: OFF (OUT) • [RF GAIN]: Upward maximum gain • [SQL]: Open • Connect signal generator to antenna connector. 	WARNING: DO NOT TRANSMIT WHILE CARRYING OUT RECEIVER ADJUSTMENT. AFTER MAKING THESE ADJUSTMENTS, AF GAIN, S-METER, AND SQUELCH SETTINGS SHOULD BE KEPT AT THESE SENSITIVITY ADJUSTMENT POSITIONS.				
	<ul style="list-style-type: none"> • Apply 0.3μV/14.10000MHz signal to antenna connector. 	REAR PANEL	Connect AC milli-voltmeter to EXTERNAL SPEAKER JACK.	Maximum sensitivity	MAIN	L69 L70 L71 L82 L83 L84
AF AMP	<ul style="list-style-type: none"> • Apply 1mV/14.10000MHz signal to antenna connector. • Tune the audio output to maximum level. 	REAR PANEL	Connect AC milli-voltmeter to EXTERNAL SPEAKER JACK.	1V rms	FRONT PANEL	AF GAIN CONTROL
	<ul style="list-style-type: none"> • Apply no signal to the antenna connector. 			30mV	MAIN	R349
S-METER	<ul style="list-style-type: none"> • Apply 50μV/14.10000MHz signal to antenna connector. 	FRONT PANEL	Use S-METER on the FRONT PANEL.	S-9	MAIN	R216
	<ul style="list-style-type: none"> • Apply 50mV/14.10000MHz signal to antenna connector. 			Full scale		R219
NOTE: Re-align R216 and R219 several times as necessary. DO NOT adjust L65, L66, L67, L68, L15, or L16.						
SQUELCH	<ul style="list-style-type: none"> • Apply no signal to the antenna connector. • Set the SQUELCH CONTROL to the threshold point. • Mode: FM 			Threshold point	MAIN	R224

ADJUSTMENT	ADJUSTMENT CONDITIONS	MEASUREMENT		VALUE	ADJUSTMENT POINT	
		UNIT	LOCATION		UNIT	ADJUST
NOISE BLANKER	<ul style="list-style-type: none"> • Display freq.: 14.10000MHz • Mode: USB • [PBT] CONTROL: Center • [ATT] SWITCH: OFF • [NB] SWITCH: ON (IN) • [NB LEVEL]: Upward • [AGC] SWITCH: Fast (Out) • [NOTCH] SWITCH: OFF (OUT) • [RIT] SWITCH: OFF (OUT) • Connect noise generator to antenna connector. • Apply 3μV noise signal to antenna connector. 					
				At point where noise is eliminated.	MAIN	L73 L74

MAIN UNIT

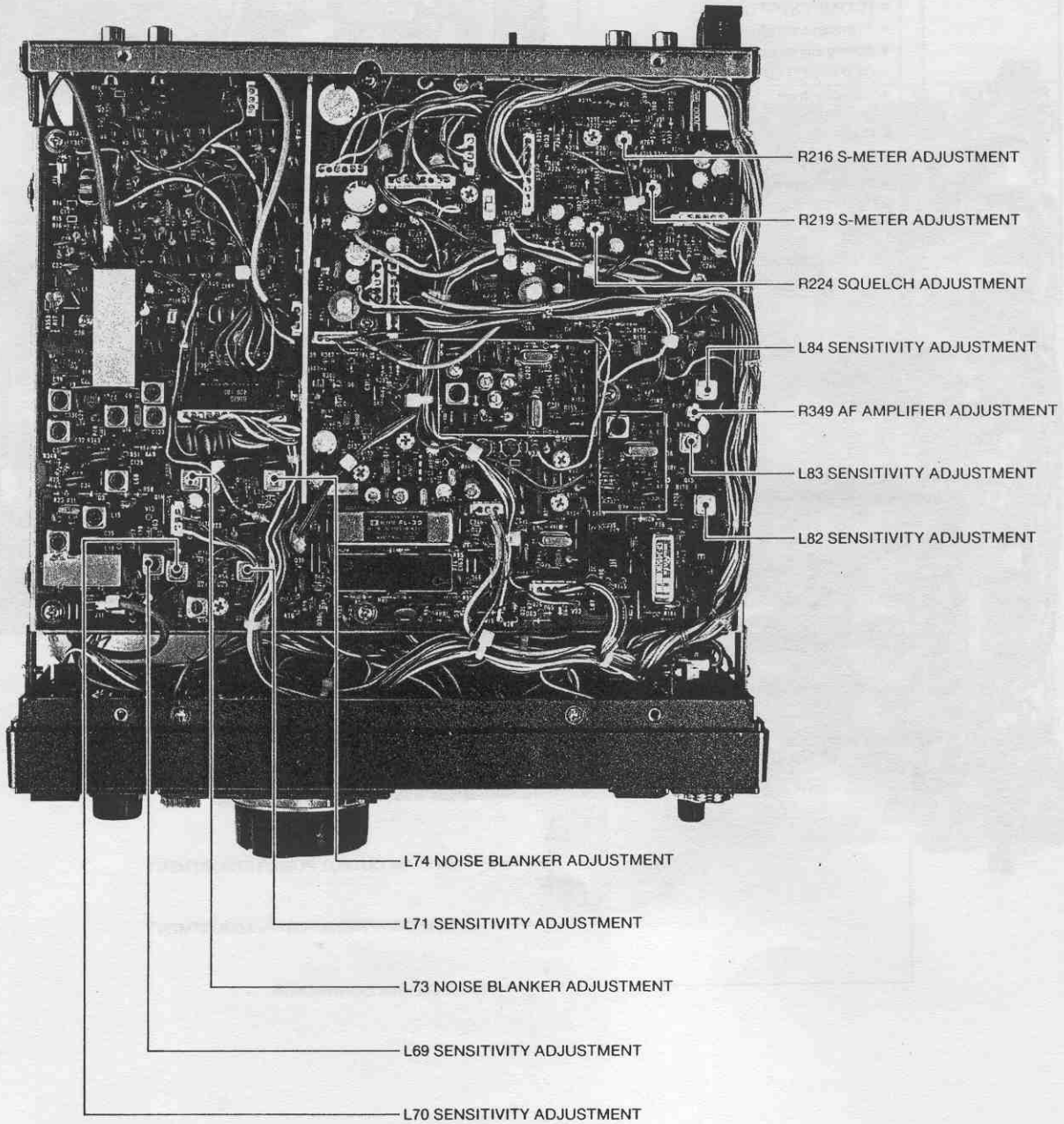

(Bottom View)

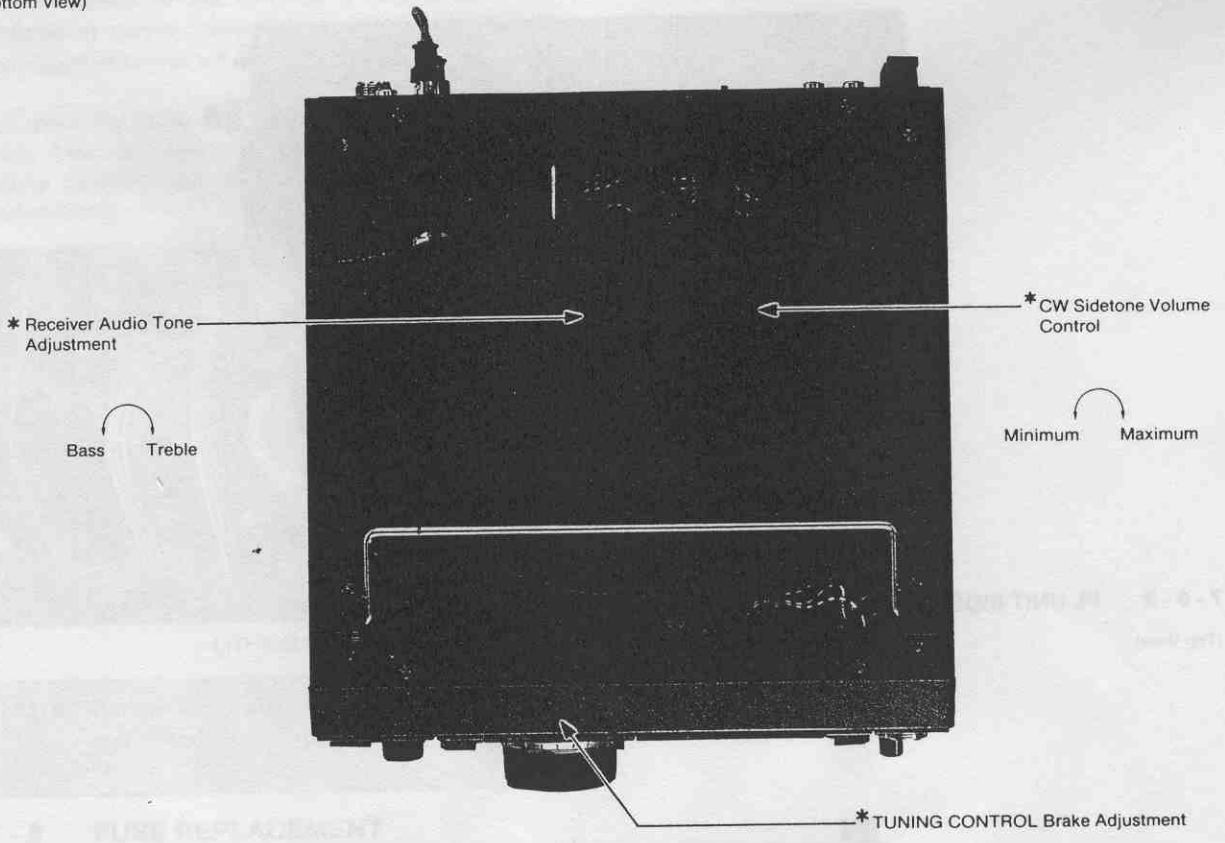

* No cover removal is necessary for adjustments.

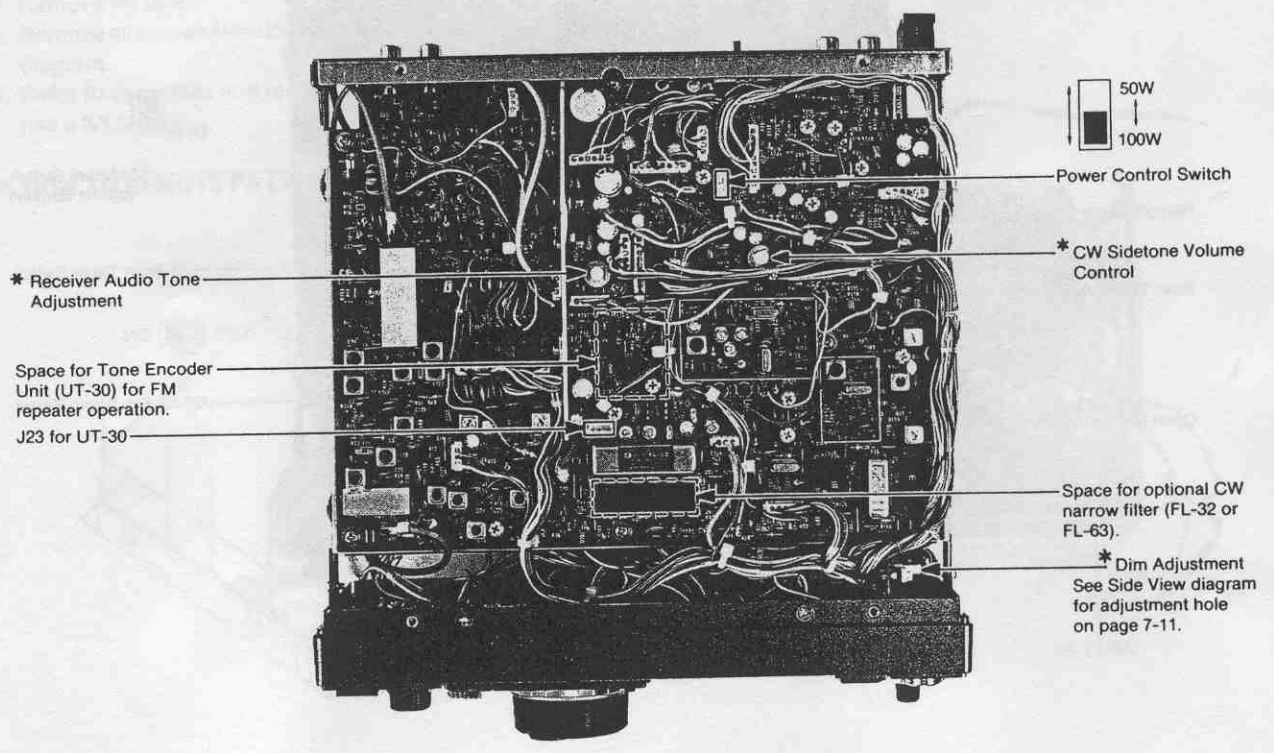

(Side View)

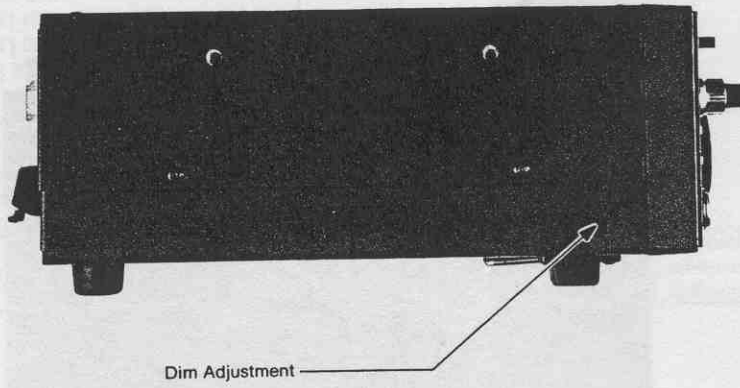

7-6-2 PL UNIT SIDE

(Top View)

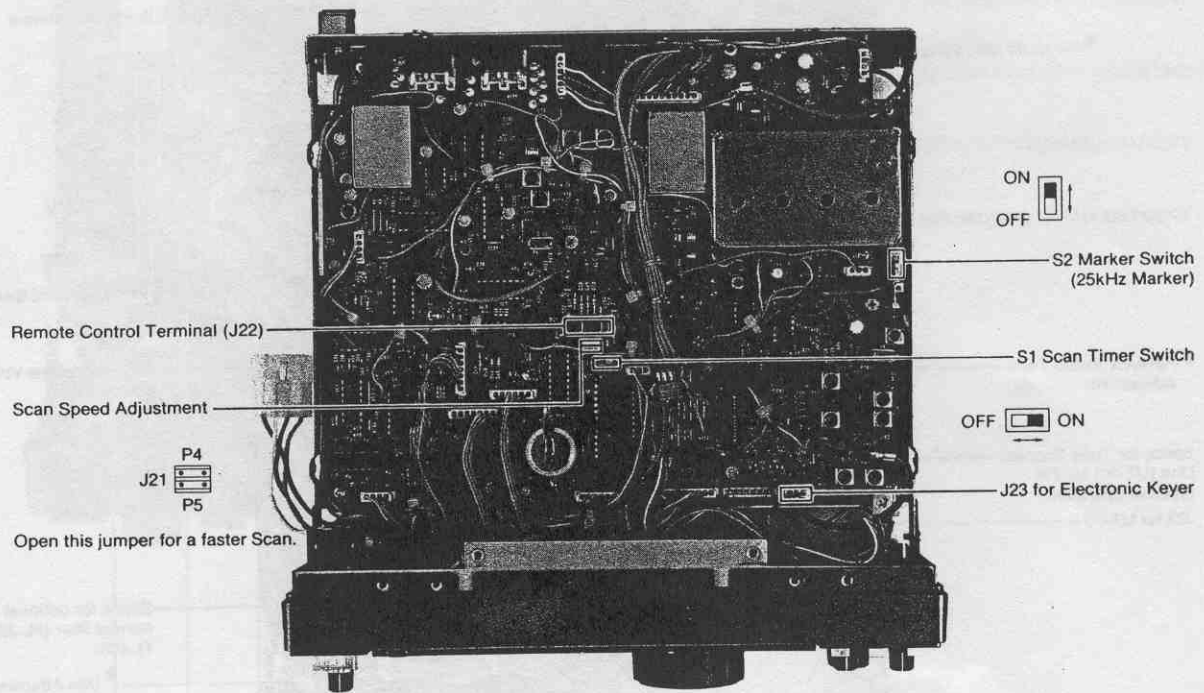

7 - 7 LITHIUM BATTERY REPLACEMENT

The IC-735 uses an advanced, highly reliable CPU with a long-life lithium battery. The purpose of the battery is to provide power to the CPU so it retains all memory information during power failures or when the unit is unplugged or turned off.

The usual life of the lithium battery is approximately five years. After five years of use, it is advisable to check the battery carefully and replace it if the LCD repeatedly malfunctions.

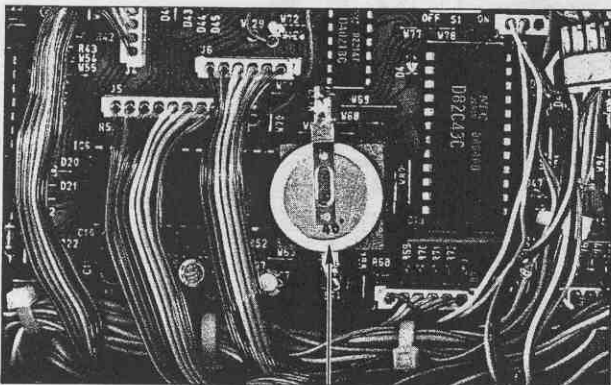

LITHIUM BATTERY

NOTE: Battery replacement should be done by an authorized ICOM dealer or ICOM service station.

7 - 8 FUSE REPLACEMENT

1. Remove top and bottom covers.
2. Remove PA unit.
3. Remove all screws from the PA unit cover as shown in the diagram.
4. Refer to the photo and replace the fuse with one which has a 3A rating.

■ HOW TO REMOVE PA COVER

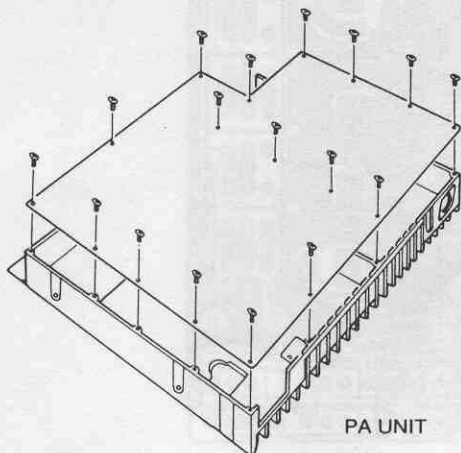

PA UNIT

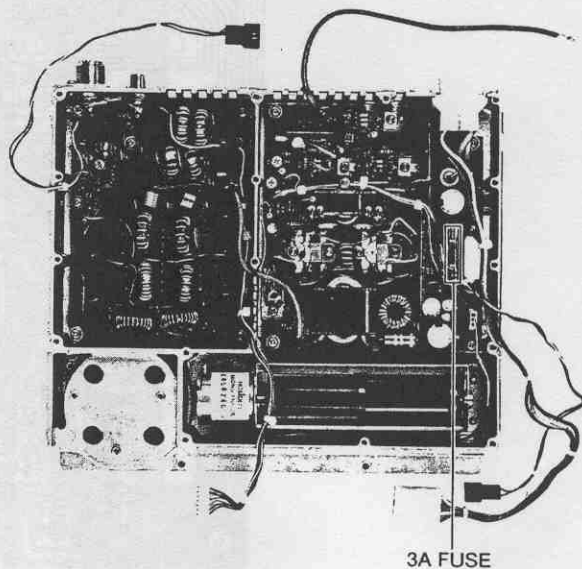

3A FUSE

SECTION 8 BOARD LAYOUTS

8 - 1 FRONT UNIT

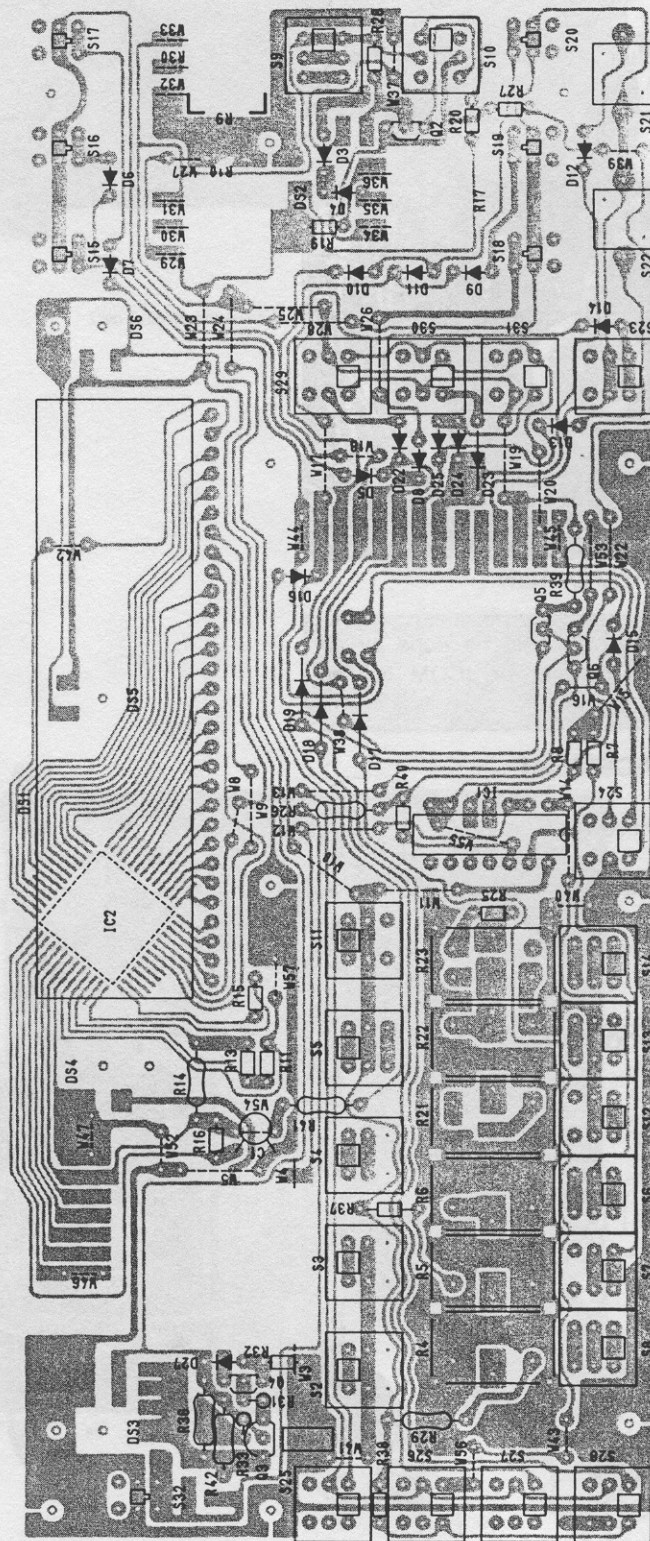

8 - 2 MAIN UNIT

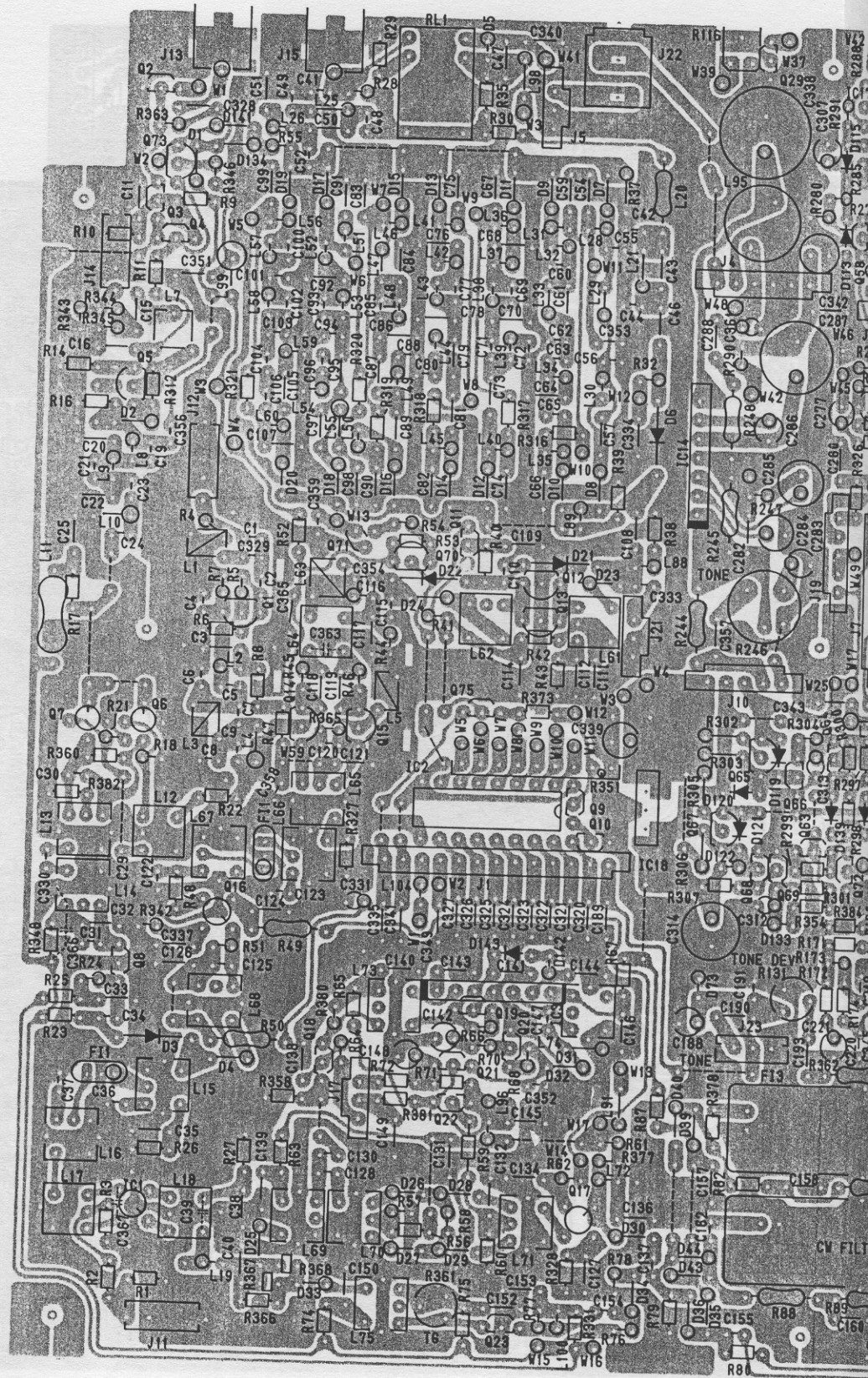

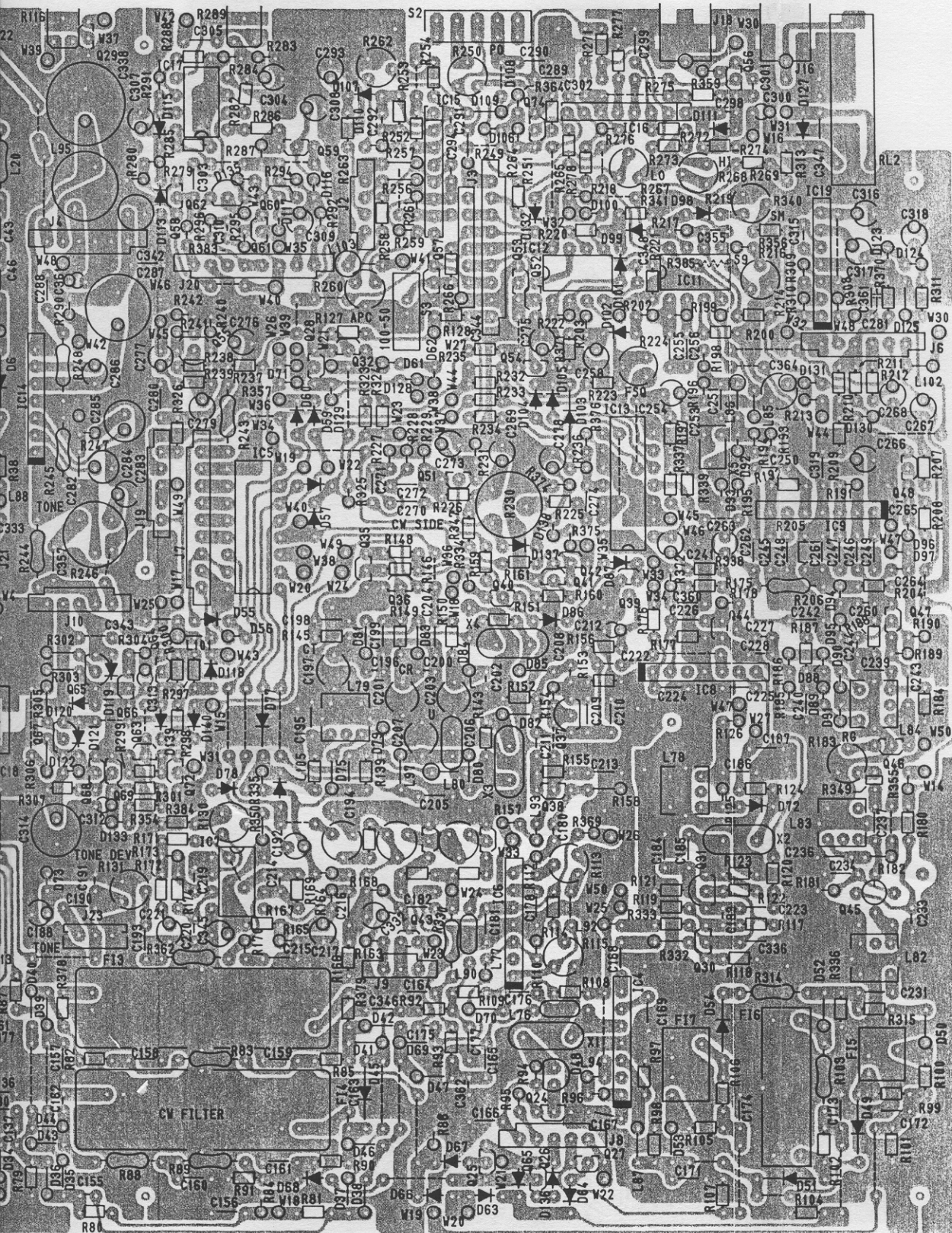

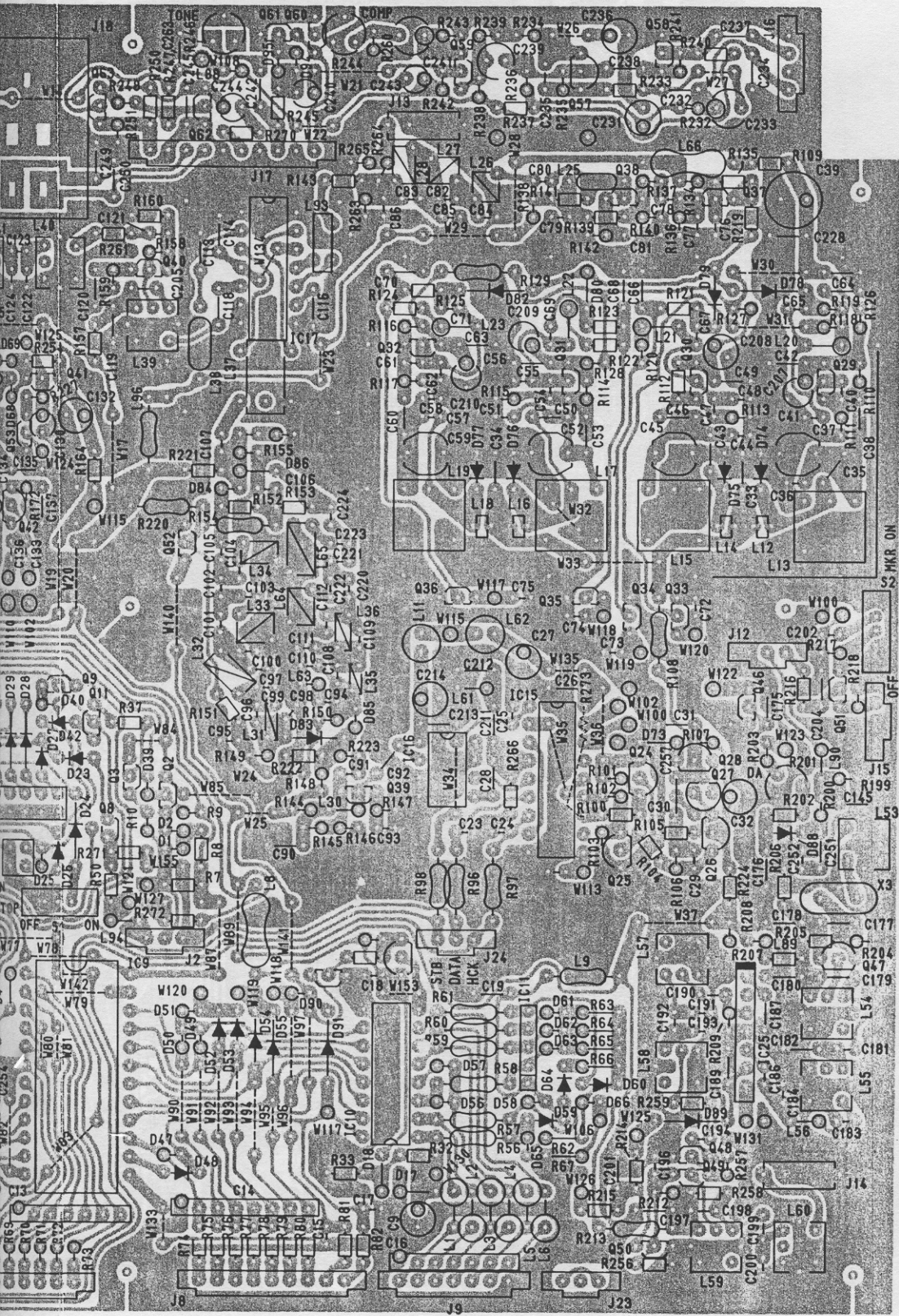

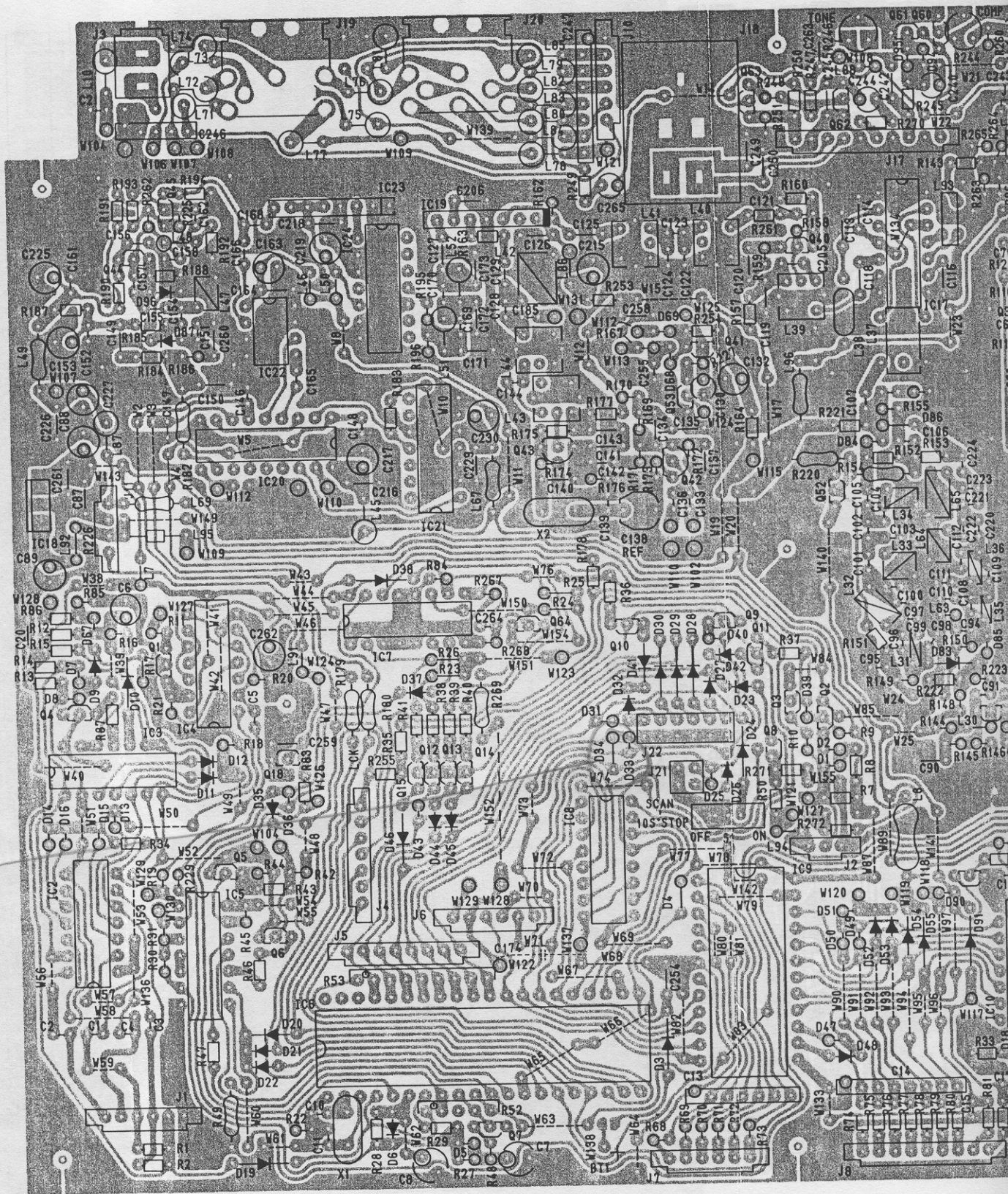

033,34
Pull TX
erage

8 - 4 PA UNIT (POWER AMPLIFIER)

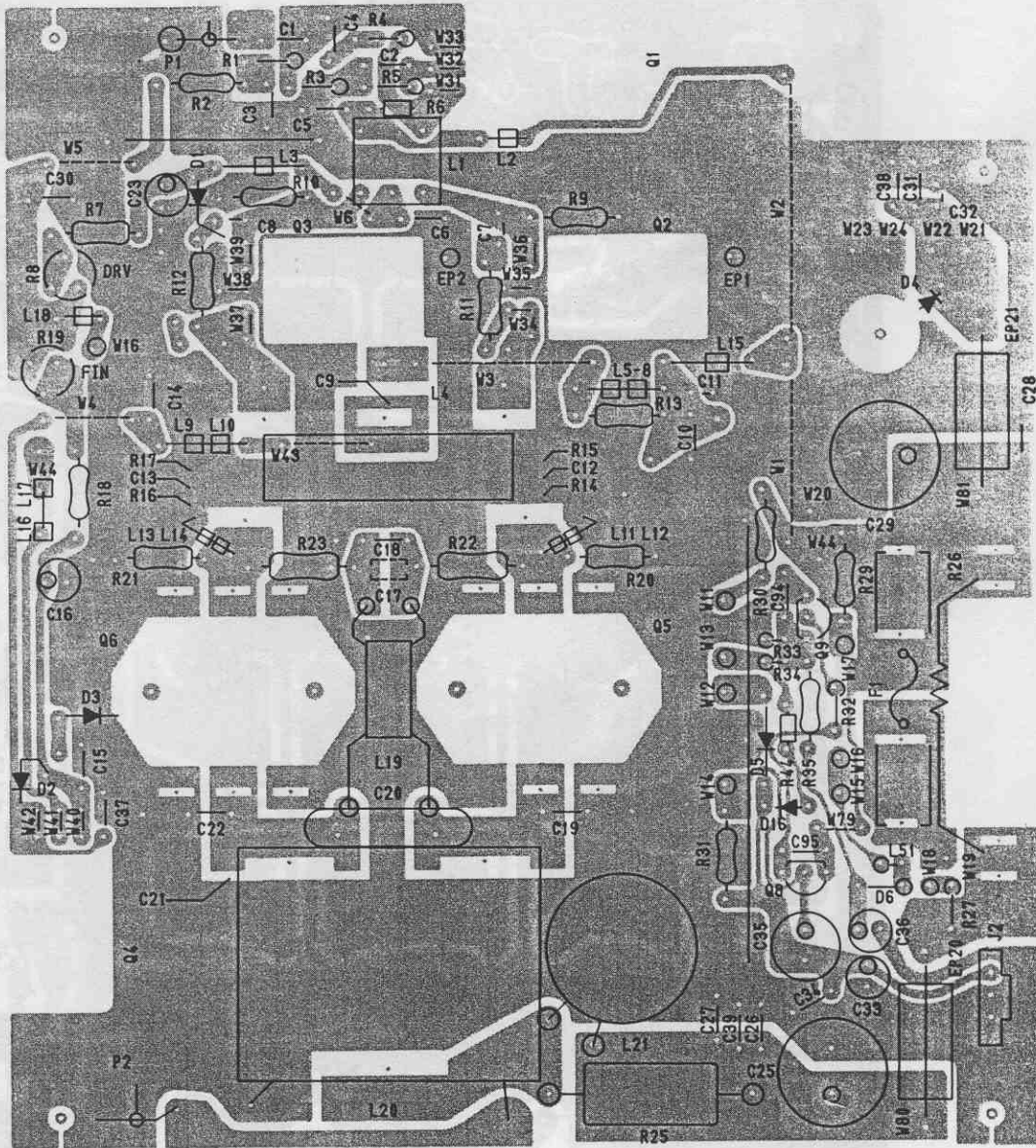

REPLACEMENT PARTS LIST

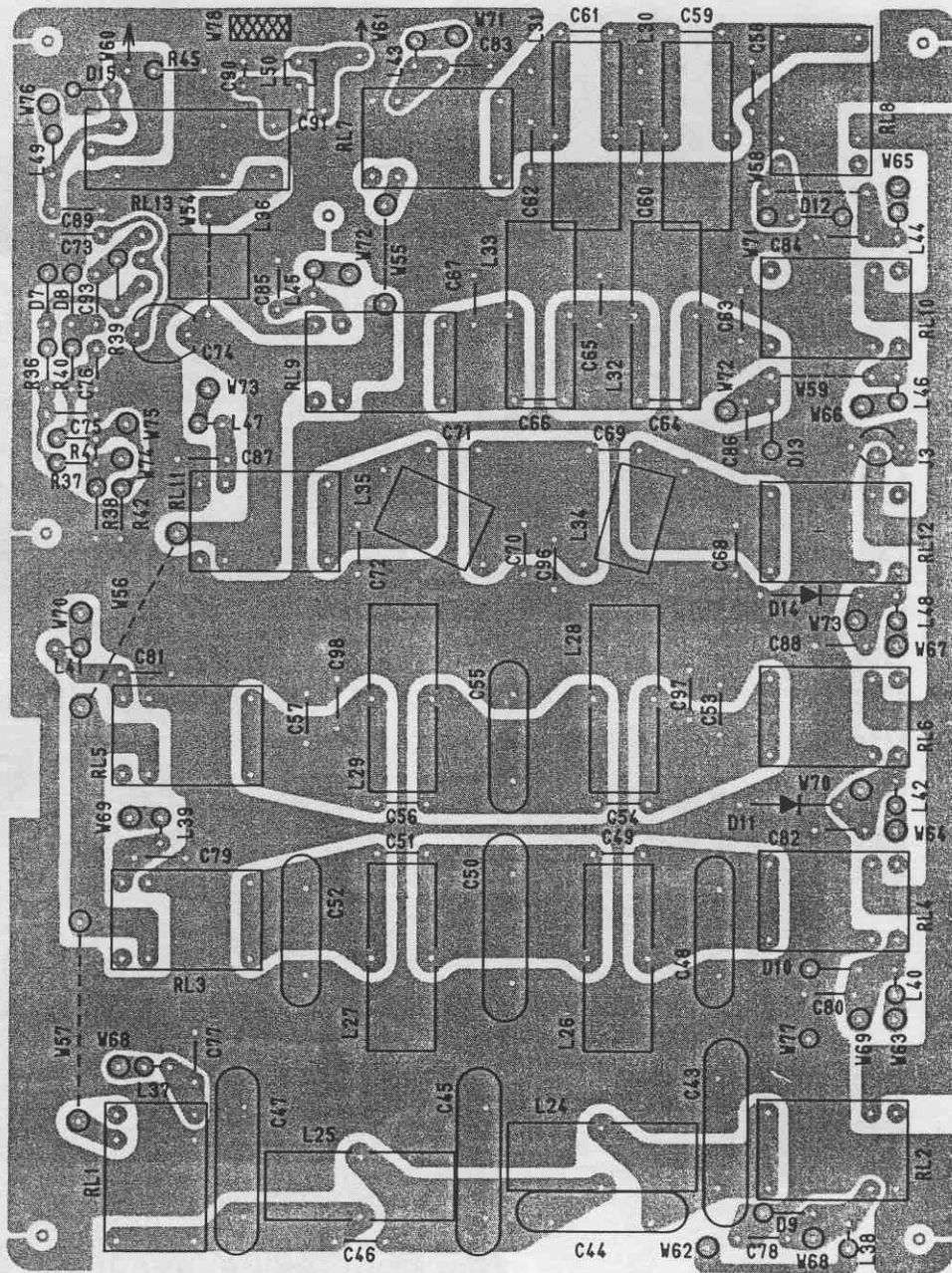

8 - 6 SENSOR UNIT

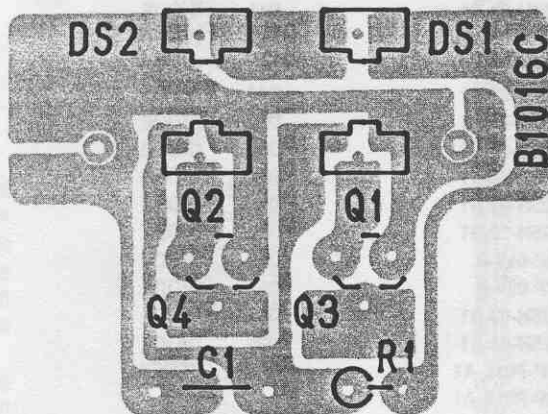

SECTION 9 PARTS LIST

[EF] UNIT			[FRONT] UNIT				
REF. NO.	DESCRIPTION	VALUE	PART NO.	REF. NO.	DESCRIPTION	VALUE	PART NO.
J1	CONNECTOR		SQ-2054	IC1	IC		μPD4066BC
				IC2	IC		μPD7225G
P1	CONNECTOR		TL25H-05-B1	Q2	TRANSISTOR		2SC3399
P2	CONNECTOR		TL25H-04-B1	Q3	TRANSISTOR		2SB562 C
P3	CONNECTOR		TL25H-06-B1	Q4	TRANSISTOR		2SC2458 GR
P4	CONNECTOR		TL25H-03-B1	Q5	TRANSISTOR		2SC2458 GR
P5	CONNECTOR		TL25H-13-B1	Q6	TRANSISTOR		2SC2458 GR
P6	CONNECTOR		TL25H-04-B1				
P7	CONNECTOR		TL25H-09-B1	D3	DIODE		1SS133
P8	CONNECTOR		TL25H-06-B1	D4	DIODE		1SS133
P9	CONNECTOR		TL25H-06-B1	D5	DIODE		1SS133
P10	CONNECTOR		TL25H-09-B1	D6	DIODE		1SS133
P11	CONNECTOR		TL25H-05-B1	D7	DIODE		1SS133
P12	CONNECTOR		TL25H-03-B1	D8	DIODE		1SS133
P13	CONNECTOR		TL25H-05-B1	D9	DIODE		1SS133
P14	CONNECTOR		TL25H-03-B1	D10	DIODE		1SS133
P15	CONNECTOR		TL25H-05-B1	D11	DIODE		1SS133
P16	CONNECTOR		TL25H-08-B1	D12	DIODE		1SS133
P17	CONNECTOR		TL25H-03-B1	D13	DIODE		1SS133
P18	CONNECTOR		TL25H-06-B1	D14	DIODE		1SS133
P19	CONNECTOR		TL25H-09-B1	D15	DIODE		1SS133
P20	CONNECTOR		TL25H-06-B1	D16	DIODE		1SS133
P21	CONNECTOR		TL25H-04-B1	D17	DIODE		1SS133
P22	CONNECTOR		TL25H-03-B1	D18	DIODE		1SS133
P23	CONNECTOR		TL25H-04-B1	D19	DIODE		1SS133
P24	CONNECTOR		TL25H-10-B1	D22	DIODE		1SS133
P25	CONNECTOR		SMP-04V-B	D23	DIODE		1SS133
P26	CONNECTOR		SMP-03V-B	D24	DIODE		1SS133
P27	CONNECTOR		TL25H-03-B1	D25	DIODE		1SS133
P28	CONNECTOR		TL25H-04-B1	D27	ZENER		RD8.2E B2
P29	CONNECTOR		TMP-P01X-A1				
P30	CONNECTOR		TMP-P01X-A1	L1	COIL	101K	LAL03NA
P31	CONNECTOR		TMP-PO1X-A1	L2	COIL	101K	LAL03NA
P32	CONNECTOR		TMP-PO1X-A1	L3	COIL	101K	LAL03NA
P33	CONNECTOR		TL25H-03-B1	L4	COIL	101K	LAL03NA
P34	CONNECTOR		TL25H-03-B1	L5	COIL	101K	LAL03NA
P35	CONNECTOR		TL25H-03-B1	L6	COIL	101K	LAL03NA
P36	CONNECTOR		BP-001	L7	COIL	101K	LAL03NA
P37	CONNECTOR		BP-001	L8	COIL	101K	LAL03NA
P38	CONNECTOR		1490P-1				
EP1	FERRITE BEADS		FSQH070RN	R1	VARIABLE	10KB,10KA	K16B10007
MP1	LEAD WIRE SUPPORT		59 TC 4772	R2	RESISTOR	100	ELR20
SP1	SPEAKER		065K1210810	R3	RESISTOR	100	ELR20
				R4	VARIABLE	10K	TSV-101SB
				R5	VARIABLE	10K	TSV-101SB
				R6	VARIABLE	10K	TSV-101SB
				R7	RESISTOR	47K	R20
				R8	RESISTOR	47K	R20
				R9	VARIABLE	10KB	K121B0006E
				R10	VARIABLE	10KB	K12140A58
				R11	RESISTOR	10K	R20
				R13	RESISTOR	10K	R20
				R14	RESISTOR	10K	R25
				R15	RESISTOR	180K	R20
				R16	RESISTOR	47K	R20
				R17	VARIABLE	10KB	K121B0006E
				R18	TRIMMER	10K	H0652A
				R19	RESISTOR	5.6K	R20

[FRONT] UNIT

REF. NO.	DESCRIPTION	VALUE	PART NO.
R20	RESISTOR	1.2K	R20
R21	VARIABLE	10K	TSV-101SB
R22	VARIABLE	1M	TSV-101SB
R23	VARIABLE	1M	TSV-101GA10KXB
R25	RESISTOR	1M	R20
R26	RESISTOR	100K	R25
R27	RESISTOR	820	R20
R28	RESISTOR	2.2K	R20
R29	RESISTOR	4.7K	R25
R30	RESISTOR	10K	R25
R31	RESISTOR	1K	ELR20
R32	RESISTOR	1K	R20
R33	RESISTOR	5.6K	ELR20
R34	TRIMMER	4.7K	H0651A
R35	RESISTOR	470	ELR20
R36	RESISTOR	100	R50X
R37	RESISTOR	3.3K	R20
R38	RESISTOR	1K	R20
R39	RESISTOR	100K	R25
R40	RESISTOR	100K	R20
R41	RESISTOR	10K	R25
R42	RESISTOR	100K	R50X
C1	BARRIER	0.1	16V
C2	BARRIER	0.047	25V
C3	BARRIER	0.0047	25V
J1	CONNECTOR		HLJ4815-01-030
J2	CONNECTOR		FM214-8SS(P)
J3	CONNECTOR		TL25P-05-V1
J4	CONNECTOR		TL25P-04-V1
J5	CONNECTOR		TL25P-06-V1
J6	CONNECTOR		TL25P-03-V1
P1	CONNECTOR		TL25H-07-B1
P2	CONNECTOR		TL25H-08-B1
P3	CONNECTOR		TL25H-06-B1
DS1	LCD		HLC9164-01-210
DS2	LED		SLB-22UR
DS3	LAMP		HRS-4200A
DS4	LAMP		HRS-4200A
DS5	LAMP		HRS-4200A
DS6	LAMP		HRS-4200A
ME1	METER		M401
S1	SWITCH		SDS-3P
S2	SWITCH		SPH121C
S3	SWITCH		SPH121C
S4	SWITCH		SPH121C
S5	SWITCH		SPH121C
S6	SWITCH		SPH121C
S7	SWITCH		SPH121C
S8	SWITCH		SPH121C
S9	SWITCH		SPH121C
S10	SWITCH		SPH121C
S11	SWITCH		SPH121C
S12	SWITCH		SPH121C
S13	SWITCH		SPH121C
S14	SWITCH		SPH121C

[FRONT] UNIT

REF. NO.	DESCRIPTION	VALUE	PART NO.
S15	SWITCH		SPH222A
S16	SWITCH		SPH222A
S17	SWITCH		SPH222A
S18	SWITCH		SPH222A
S19	SWITCH		SPH222A
S20	SWITCH		SPH222A
S21	SWITCH		KEC10901
S22	SWITCH		KEC10901
S23	SWITCH		SPH122C
S24	SWITCH		SPH121C
S25	SWITCH		SPH122C
S26	SWITCH		SPH122C
S27	SWITCH		SPH122C
S28	SWITCH		SPH122C
S29	SWITCH		SPH121C
S30	SWITCH		SPH121C
S31	SWITCH		SPH121C
S32	SWITCH		SPH221A
EP1	PC BOARD		B-1006C
EP2	PC BOARD		B-1007D
EP3	PC BOARD		B-1031A
W3	JUMPER		JPW-02A
W4	JUMPER		JPW-02A
W5	JUMPER		IPS-1041-4
W8	JUMPER		IPS-1041-2
W9	JUMPER		IPS-1041-4
W10	JUMPER		IPS-1041-4
W11	JUMPER		IPS-1041-4
W12	JUMPER		IPS-1041-4
W13	JUMPER		IPS-1041-4
W14	JUMPER		IPS-1041-4
W15	JUMPER		IPS-1041-4
W16	JUMPER		IPS-1041-2
W17	JUMPER		IPS-1041-4
W18	JUMPER		IPS-1041-2
W19	JUMPER		IPS-1041-4
W20	JUMPER		IPS-1041-4
W22	JUMPER		IPS-1041-4
W23	JUMPER		IPS-1041-4
W24	JUMPER		IPS-1041-4
W25	JUMPER		IPS-1041-4
W26	JUMPER		IPS-1041-4
W27	JUMPER		IPS-1041-2
W28	JUMPER		IPS-1041-4
W29	JUMPER		JPW-02A
W30	JUMPER		JPW-02A
W31	JUMPER		JPW-02A
W32	JUMPER		JPW-02A
W33	JUMPER		JPW-02A
W35	JUMPER		JPW-02A
W36	JUMPER		JPW-02A
W37	JUMPER		IPS-1041-2
W38	JUMPER		IPS-1041-2
W39	JUMPER		IPS-1041-2
W40	JUMPER		IPS-1041-2
W41	JUMPER		IPS-1041-2
W42	JUMPER		IPS-1041-2
W43	JUMPER		IPS-1041-2
W44	JUMPER		IPS-1041-2

[FRONT] UNIT

REF. NO.	DESCRIPTION	VALUE	PART NO.
W45	JUMPER		IPS-1041-2
W46	JUMPER		IPS-1041-2
W47	JUMPER		IPS-1041-2
W48	JUMPER		23/05/100/W01/W01
W49			OPC-106
W50			OPC-107
W51			OPC-105
W52	JUMPER		IPS-1041-2
W53	JUMPER		IPS-1041-4
W54	JUMPER		IPS-1041-2
W55	JUMPER		IPS-1041-4
W56	JUMPER		IPS-1041-2
W57	JUMPER		IPS-1041-2

[MAIN] UNIT

REF. NO.	DESCRIPTION	VALUE	PART NO.
IC1	IC		ND487C1-3R
IC2	IC		BA618
IC3	IC		uPC577H
IC4	IC		uPC1037H
IC5	IC		BA618
IC6	IC		uPC1037H
IC7	IC		NJM4558D
IC8	IC		uPC1037H
IC9	IC		uPC577H
IC11	IC		NJM082D
IC12	IC		NJM4558D
IC13	IC		TC4066BP
IC14	IC		uPC1181H
IC15	IC		M5218L
IC16	IC		M5218L
IC17	IC		NJM4558D
IC18	IC		uA78M08
IC19	IC		BA222
Q1	TRANSISTOR		2SC2053
Q2	TRANSISTOR		2SC3399
Q3	TRANSISTOR		2SA1348
Q4	TRANSISTOR		2SA1348
Q5	TRANSISTOR		2SC2053
Q6	FET		3SK74 K
Q7	FET		3SK74 K
Q8	FET		2SK241 GR
Q9	TRANSISTOR		2SA1348
Q10	TRANSISTOR		2SC3399
Q11	TRANSISTOR		2SA1348
Q12	FET		2SK125
Q13	FET		2SK125
Q14	FET		2SK125
Q15	FET		2SK125
Q16	FET		3SK74 M
Q17	FET		3SK74 M
Q18	FET		2SK192A Y
Q19	TRANSISTOR		2SA1048
Q20	TRANSISTOR		2SC2458 GR
Q21	TRANSISTOR		2SC2458 GR
Q22	TRANSISTOR		2SA1348

[MAIN] UNIT

REF. NO.	DESCRIPTION	VALUE	PART NO.
Q23	FET		2SK241 GR
Q24	TRANSISTOR		2SC2458 GR
Q25	TRANSISTOR		2SA1348
Q26	TRANSISTOR		2SA1348
Q27	TRANSISTOR		2SA1348
Q28	TRANSISTOR		2SC3399
Q29	TRANSISTOR		2SC3402
Q30	TRANSISTOR		2SC2458 GR
Q31	TRANSISTOR		2SC1815 Y
Q32	TRANSISTOR		2SC3399
Q35	TRANSISTOR		2SC3399
Q36	TRANSISTOR		2SC3399
Q37	TRANSISTOR		2SC1815 Y
Q38	TRANSISTOR		2SC2458 GR
Q39	TRANSISTOR		2SC3402
Q40	TRANSISTOR		2SC3402
Q41	TRANSISTOR		2SC3402
Q42	TRANSISTOR		2SC3402
Q43	TRANSISTOR		2SC2458 GR
Q44	TRANSISTOR		2SC2458 GR
Q45	FET		3SK74 M
Q46	FET		2SK241 Y
Q47	TRANSISTOR		2SC2458 GR
Q48	TRANSISTOR		2SC2458 GR
Q51	TRANSISTOR		2SC2458 GR
Q52	TRANSISTOR		2SC3402
Q53	TRANSISTOR		2SC3399
Q54	TRANSISTOR		2SA1048 Y
Q55	TRANSISTOR		2SC1571 G
Q56	TRANSISTOR		2SA1048 Y
Q57	TRANSISTOR		2SC3402
Q58	TRANSISTOR		2SC2458 GR
Q59	TRANSISTOR		2SA1048 Y
Q60	TRANSISTOR		2SC2458 GR
Q61	TRANSISTOR		2SA1048 Y
Q62	TRANSISTOR		2SD468 C
Q63	TRANSISTOR		2SC2458 GR
Q64	TRANSISTOR		2SC2458 GR
Q65	TRANSISTOR		2SD468 C
Q66	TRANSISTOR		2SC2458 GR
Q67	TRANSISTOR		2SD468 C
Q68	TRANSISTOR		2SC2458 GR
Q69	TRANSISTOR		2SC3399
Q70	TRANSISTOR		2SB562 C
Q71	TRANSISTOR		2SC3402
Q72	TRANSISTOR		2SC3399
Q73	TRANSISTOR		2SD468 C
Q74	TRANSISTOR		2SC2458 GR
Q75	TRANSISTOR		2SA1048 GR
D1	DIODE		1SS53
D2	DIODE		1SS53
D3	DIODE		1SS53
D4	DIODE		1SS53
D5	DIODE		1SS53
D6	DIODE		1SS53
D7	DIODE		1SS53
D8	DIODE		1SS53
D9	DIODE		1SS53
D10	DIODE		1SS53
D11	DIODE		1SS53
D12	DIODE		1SS53

[MAIN] UNIT

REF. NO.	DESCRIPTION	VALUE	PART NO.
D13	DIODE		1SS53
D14	DIODE		1SS53
D15	DIODE		1SS53
D16	DIODE		1SS53
D17	DIODE		1SS53
D18	DIODE		1SS53
D19	DIODE		1SS53
D20	DIODE		1SS53
D21	DIODE		1SS53
D22	DIODE		1SS53
D23	DIODE		1SS53
D24	DIODE		1SS53
D25	DIODE		1SS53
D26	DIODE		1SS53
D27	DIODE		1SS53
D28	DIODE		1SS53
D29	DIODE		1SS53
D30	DIODE		1SS53
D31	DIODE		1K60
D32	DIODE		1K60
D33	DIODE		1SS53
D34	DIODE		1SS53
D35	DIODE		1SS53
D36	DIODE		1SS53
D37	DIODE		1SS53
D38	DIODE		1SS53
D39	DIODE		1SS53
D40	DIODE		1SS53
D41	DIODE		1SS53
D42	DIODE		1SS53
D43	DIODE		1SS53
D44	DIODE		1SS53
D45	DIODE		1SS53
D46	DIODE		1SS53
D47	DIODE		1SS53
D48	VARICAP		FC52M
D49	DIODE		1SS53
D50	DIODE		1SS53
D51	DIODE		1SS53
D52	DIODE		1SS53
D53	DIODE		1SS53
D54	DIODE		1SS53
D55	DIODE		1SS133
D56	DIODE		1SS133
D57	DIODE		1SS133
D59	DIODE		1SS133
D60	DIODE		1SS133
D61	DIODE		1SS133
D62	DIODE		1SS133
D63	DIODE		1SS133
D64	DIODE		1SS133
D65	DIODE		1SS133
D66	DIODE		1SS133
D67	DIODE		1SS133
D68	DIODE		1SS133
D69	DIODE		1SS53
D70	DIODE		1SS53
D71	DIODE		1SS133
D72	VARICAP		1SV50E
D73	ZENER		RD5.1E B2
D75	VARICAP		1SV50E
D77	DIODE		1SS133
D78	DIODE		1SS133

[MAIN] UNIT

REF. NO.	DESCRIPTION	VALUE	PART NO.
D79	DIODE		1SS53
D80	DIODE		1SS216
D81	DIODE		1SS53
D82	DIODE		1SS53
D83	DIODE		1SS53
D84	DIODE		1SS53
D85	DIODE		1SS53
D86	DIODE		1SS133
D87	DIODE		1SS133
D88	DIODE		1K60
D89	DIODE		1K60
D90	DIODE		1K60
D91	DIODE		1K60
D92	DIODE		1K60
D93	DIODE		1K60
D94	DIODE		1K60
D95	DIODE		1K60
D96	DIODE		1K60
D97	DIODE		1K60
D98	DIODE		1SS133
D99	DIODE		1SS133
D100	DIODE		1SS133
D101	DIODE		1SS133
D102	DIODE		1SS133
D103	DIODE		1SS133
D104	DIODE		1SS133
D105	DIODE		1SS133
D106	DIODE		1SS133
D107	DIODE		1SS133
D108	DIODE		1SS133
D109	ZENER		MZ303 B
D110	DIODE		1SS133
D111	DIODE		1SS133
D113	DIODE		1SS133
D115	DIODE		1SS133
D116	DIODE		1SS133
D117	DIODE		1SS133
D118	DIODE		1SS133
D119	DIODE		1SS133
D120	DIODE		1SS133
D121	DIODE		1SS133
D122	DIODE		1SS133
D123	DIODE		1SS133
D124	DIODE		1SS133
D125	ZENER		RD5.1E B2
D127	DIODE		1SS133
D128	DIODE		1SS133
D129	DIODE		1SS133
D130	DIODE		1SS133
D131	DIODE		1SS216
D132	DIODE		1SS133
D133	DIODE		1SS133
D134	DIODE		1SS53
D135	ZENER		MZ303 B
D136	DIODE		1SS133
D137	DIODE		1SS133
D138	DIODE		1SS133
D139	DIODE		1SS133
D140	DIODE		1SS133
D141	DIODE		1SS53
D142	DIODE		1SS133
D143	DIODE		1SS133

[MAIN] UNIT

REF. NO.	DESCRIPTION	VALUE	PART NO.
F11	CRYSTAL		FL-64
F13	CRYSTAL		FL-30
F15	CERAMIC		CFU455E2
F16	CERAMIC		FL-65
F17	CERAMIC		CFW455HT
X1	CRYSTAL		HC12/U9.0105
X2	CRYSTAL		CR1 HC43/U9.4665
X3	CRYSTAL		CR49 HC43/U9.0145
X4	CRYSTAL		CR48 HC43/U9.0115
X5	DISCRIMINATOR		CFY455S
L1	COIL		LA-246
L2	COIL	R56M	LAL03NA
L3	COIL		LA-248
L4	COIL	R27M	LAL03NA
L5	COIL		LA-245
L7	COIL		LR-20
L8	COIL	R27M	LAL03NA
L9	COIL	R33M	LAL03NA
L10	COIL	5R6K	LAL03NA
L11	COIL	102K	LAL04NA
L12	COIL		LR-116
L13	COIL		LS-198
L14	COIL		LS-114
L15	COIL		LS-254
L16	COIL		LS-254
L17	COIL		LR-116
L18	COIL		LR-116
L19	COIL	R82M	LAL03NA
L20	COIL	270K	LAL03NA
L21	COIL	220K	LAL03NA
L25	COIL	4R7K	LAL03NA
L26	COIL	3R9K	LAL03NA
L28	COIL	101K	LAL03NA
L29	COIL	6R8K	LAL03NA
L30	COIL	4R7K	LAL03NA
L31	COIL	101K	LAL03NA
L32	COIL	2R7K	LAL03NA
L33	COIL	2R2K	LAL03NA
L34	COIL	2R7K	LAL03NA
L35	COIL	3R3K	LAL03NA
L36	COIL	101K	LAL03NA
L37	COIL	1R8K	LAL03NA
L38	COIL	1R2K	LAL03NA
L39	COIL	1R5K	LAL03NA
L40	COIL	1R5K	LAL03NA
L41	COIL	101K	LAL03NA
L42	COIL	1R2K	LAL03NA
L43	COIL	1R0K	LAL03NA
L44	COIL	R82M	LAL03NA
L45	COIL	R82M	LAL03NA
L46	COIL	101K	LAL03NA
L47	COIL	R82M	LAL03NA
L48	COIL	R68M	LAL03NA
L49	COIL	R68M	LAL03NA
L50	COIL	R56M	LAL03NA
L51	COIL	101K	LAL03NA
L52	COIL	R47M	LAL03NA
L53	COIL	R47M	LAL03NA

[MAIN] UNIT

REF. NO.	DESCRIPTION	VALUE	PART NO.
L54	COIL	R47M	LAL03NA
L55	COIL	R47M	LAL03NA
L56	COIL	101K	LAL03NA
L57	COIL	R27M	LAL03NA
L58	COIL	R27M	LAL03NA
L59	COIL	R33M	LAL03NA
L60	COIL	R33M	LAL03NA
L61	COIL		LR-86
L62	COIL		LR-18
L63	COIL		LA-248
L64	COIL		LR-116
L65	COIL		LS-198
L66	COIL		LS-254
L67	COIL		LS-254
L68	COIL		LS-114
L69	COIL		LS-163
L70	COIL		LS-90A
L71	COIL		LS-90A
L72	COIL	150K	LAL03NA
L73	COIL		LS-175
L74	COIL		LS-175
L75	COIL		LS-163
L76	COIL	150K	LAL03NA
L77	COIL	100K	LAL03NA
L78	COIL		LS-133A
L79	COIL		LS-282
L80	COIL	150K	LAL04NA
L82	COIL		LS-240
L83	COIL		LS-238
L84	COIL		LS-240
L85	COIL	102K	LAL04NA
L86	COIL	102K	LAL04NA
L87	COIL	221K	LAL03NA
L88	COIL	101K	LAL03NA
L89	COIL	101K	LAL03NA
L90	COIL	101K	LAL03NA
L91	COIL	101K	LAL03NA
L92	COIL	101K	LAL03NA
L93	COIL	101K	LAL03NA
L94	COIL	100K	LAL03NA
L95	COIL		LW-15
L96	COIL	101K	LAL03NA
L97	COIL	101K	LAL03NA
L98	COIL	101K	LAL03NA
L99	COIL		BTO1RN1-A-A61
L100	COIL	150K	LAL03NA
L101	COIL		BT01RN1-A61
L102	COIL		BT01RN1-A61
L103	COIL	100K	LAL03NA
L104	COIL	101K	LAL03NA
L105	COIL	101K	LAL03NA
L106	COIL	1R0K	LAL03NA
R1	RESISTOR	270	R20
R2	RESISTOR	18	R20
R3	RESISTOR	270	R20
R4	RESISTOR	68	ELR20
R5	RESISTOR	5.6K	ELR20
R6	RESISTOR	680	R20
R7	RESISTOR	22	ELR20
R8	RESISTOR	47	R20
R9	RESISTOR	10K	R20
R10	RESISTOR	10K	R20

[MAIN] UNIT

REF. NO.	DESCRIPTION	VALUE	PART NO.
R11	RESISTOR	22	R20
R14	RESISTOR	5.6	R20
R16	RESISTOR	680	R20
R17	RESISTOR	56	R20
R18	RESISTOR	100K	ELR20
R21	RESISTOR	100K	ELR20
R22	RESISTOR	47	R20
R23	RESISTOR	4.7K	R20
R24	RESISTOR	6.8K	ELR20
R25	RESISTOR	150	R20
R26	RESISTOR	4.7K	R20
R27	RESISTOR	4.7K	R20
R28	RESISTOR	390	ELR20
R29	RESISTOR	56	R20
R30	RESISTOR	47	R20
R32	RESISTOR	330	ELR20
R35	RESISTOR	47K	R20
R37	RESISTOR	470	ELR25
R38	RESISTOR	220	R20
R39	RESISTOR	470	R20
R40	RESISTOR	220	R20
R41	RESISTOR	4.7	ELR20
R42	RESISTOR	220	R20
R43	RESISTOR	22	R20
R44	RESISTOR	470	ELR20
R45	RESISTOR	470	ELR20
R46	RESISTOR	470	ELR20
R47	RESISTOR	47	R20
R48	RESISTOR	22	R20
R49	RESISTOR	1M	R25
R50	RESISTOR	47	R25
R51	RESISTOR	2.2K	ELR20
R52	RESISTOR	1	R20
R53	RESISTOR	6.8K	R20
R54	RESISTOR	2.2K	ELR20
R55	RESISTOR	220	R20
R56	RESISTOR	2.2K	R20
R57	RESISTOR	2.2K	ELR20
R58	RESISTOR	220	ELR20
R59	RESISTOR	47	R20
R60	RESISTOR	1K	R20
R61	RESISTOR	100	ELR20
R62	RESISTOR	470	ELR20
R63	RESISTOR	4.7K	R20
R64	RESISTOR	100	ELR20
R65	RESISTOR	100	R20
R66	RESISTOR	100K	ELR20
R67	RESISTOR	100	R20
R68	RESISTOR	47K	ELR20
R70	RESISTOR	10K	ELR20
R71	RESISTOR	6.8K	R20
R72	RESISTOR	330	R20
R74	RESISTOR	4.7K	R20
R75	RESISTOR	100	R20
R76	RESISTOR	10K	ELR20
R77	RESISTOR	4.7K	ELR20
R78	RESISTOR	4.7K	ELR20
R79	RESISTOR	10K	R20
R80	RESISTOR	1.5K	R20
R81	RESISTOR	1.5K	R20
R82	RESISTOR	2.2K	R20

[MAIN] UNIT

REF. NO.	DESCRIPTION	VALUE	PART NO.
R83	RESISTOR	100	R25
R84	RESISTOR	2.2K	ELR20
R85	RESISTOR	2.2K	R20
R86	RESISTOR	2.2K	ELR20
R87	RESISTOR	10K	R20
R88	RESISTOR	2.2K	R25
R89	RESISTOR	100K	R25
R90	RESISTOR	2.2K	R20
R91	RESISTOR	2.2K	R20
R92	RESISTOR	10K	R20
R93	RESISTOR	10K	R20
R94	RESISTOR	47K	ELR20
R95	RESISTOR	1K	ELR20
R96	RESISTOR	100	ELR20
R97	RESISTOR	2.2K	R20
R98	RESISTOR	5.6K	R20
R99	RESISTOR	10K	R20
R100	RESISTOR	10K	R20
R101	RESISTOR	2.2K	R20
R102	RESISTOR	10K	R20
R103	RESISTOR	10K	R25
R104	RESISTOR	2.2K	R20
R105	RESISTOR	10K	R20
R106	RESISTOR	10K	R20
R107	RESISTOR	2.2K	R20
R108	RESISTOR	10K	R20
R109	RESISTOR	47	R20
R110	RESISTOR	2.2K	ELR20
R112	RESISTOR	220K	ELR20
R113	TRIMMER	10K	H0651A
R114	RESISTOR	220K	R20
R115	TRIMMER	10K	H0651A
R116	TRIMMER	10K	H0652A
R117	RESISTOR	10K	R20
R118	RESISTOR	1K	R20
R119	RESISTOR	4.7K	R20
R120	RESISTOR	100	R20
R121	RESISTOR	1.5K	R20
R122	RESISTOR	22K	R20
R123	RESISTOR	10K	R20
R124	RESISTOR	100K	R20
R125	RESISTOR	10K	ELR20
R126	RESISTOR	100K	ELR20
R127	RESISTOR	100K	R20
R128	RESISTOR	100K	R20
R130	TRIMMER	4.7	H0651A
R131	TRIMMER	100K	H0651A
R139	RESISTOR	100K	R20
R143	RESISTOR	4.7K	R20
R145	RESISTOR	2.2K	R20
R146	RESISTOR	2.2K	R20
R148	RESISTOR	2.2K	R20
R149	RESISTOR	2.2K	R20
R150	RESISTOR	4.7K	R20
R151	RESISTOR	4.7K	R20
R152	RESISTOR	10K	R20
R153	RESISTOR	10K	R20
R154	RESISTOR	22K	ELR20
R155	RESISTOR	100K	R20
R156	RESISTOR	1K	R20
R157	RESISTOR	100	ELR20

[MAIN] UNIT

REF. NO.	DESCRIPTION	VALUE	PART NO.
R158	RESISTOR	2.2K	R25
R159	RESISTOR	10K	R20
R160	RESISTOR	10K	R20
R161	RESISTOR	10K	R20
R163	RESISTOR	470	ELR20
R164	RESISTOR	1.2K	ELR20
R165	RESISTOR	1.2K	ELR20
R166	RESISTOR	10K	R20
R167	RESISTOR	1K	R20
R168	RESISTOR	2.2K	ELR20
R169	RESISTOR	220K	R20
R170	RESISTOR	1K	ELR20
R171	RESISTOR	1K	R20
R172	RESISTOR	4.7K	R20
R173	RESISTOR	5.6K	ELR20
R174	RESISTOR	6.8K	R20
R175	RESISTOR	1K	R20
R176	RESISTOR	220	R20
R177	RESISTOR	2.2K	R20
R178	RESISTOR	470	ELR20
R180	RESISTOR	470	R20
R181	RESISTOR	150	ELR20
R182	RESISTOR	100	ELR20
R183	TRIMMER	47K	H0651A
R184	RESISTOR	100	R20
R185	RESISTOR	220	ELR20
R186	RESISTOR	220	ELR20
R187	RESISTOR	1.5K	R20
R188	RESISTOR	1K	R20
R189	RESISTOR	220K	ELR20
R190	RESISTOR	470	ELR20
R191	RESISTOR	100	ELR20
R192	RESISTOR	330	R20
R193	RESISTOR	220	ELR20
R194	RESISTOR	10K	ELR20
R195	RESISTOR	10K	ELR20
R196	RESISTOR	4.7K	ELR20
R197	RESISTOR	100K	R20
R198	RESISTOR	1K	ELR20
R199	RESISTOR	1.8M	ELR20
R200	RESISTOR	1.8M	R20
R202	RESISTOR	1K	ELR20
R203	RESISTOR	100K	ELR20
R204	RESISTOR	100K	R20
R205	RESISTOR	68K	R20
R206	RESISTOR	10K	R25
R207	RESISTOR	1K	R20
R208	RESISTOR	4.7K	R20
R209	RESISTOR	100K	R20
R210	RESISTOR	22K	R20
R211	RESISTOR	1M	R20
R212	RESISTOR	10K	R20
R213	RESISTOR	22K	ELR20
R214	RESISTOR	2.2M	R20
R216	TRIMMER	10K	H0651A
R217	RESISTOR	4.7M	ERC14GJ
R218	RESISTOR	22K	ELR20
R219	TRIMMER	10K	H0651A
R220	RESISTOR	470K	R20
R221	RESISTOR	470K	R20
R222	RESISTOR	330K	ELR20
R223	RESISTOR	68K	R20

[MAIN] UNIT

REF. NO.	DESCRIPTION	VALUE	PART NO.
R224	TRIMMER	10K	H0651A
R225	RESISTOR	47K	R20
R226	RESISTOR	27K	R20
R227	RESISTOR	4.7K	ELR20
R228	RESISTOR	4.7K	ELR20
R229	RESISTOR	5.6K	ELR20
R230	TRIMMER	1K	H1051C
R231	RESISTOR	330	ELR20
R232	RESISTOR	10K	R20
R233	RESISTOR	10K	R20
R234	RESISTOR	10K	R20
R235	RESISTOR	2.2K	R20
R236	RESISTOR	10K	ELR20
R237	RESISTOR	470	R20
R238	RESISTOR	2.2	R20
R239	RESISTOR	100K	R20
R240	RESISTOR	100	ELR20
R241	RESISTOR	22K	ELR20
R242	RESISTOR	10K	ELR20
R243	RESISTOR	220	R25
R244	RESISTOR	3.3K	R25
R245	RESISTOR	10K	R25
R246	TRIMMER	10K	H1051C
R247	RESISTOR	68	ELR20
R248	RESISTOR	1	R25
R249	RESISTOR	220	ELR20
R250	TRIMMER	1M	H0651A
R251	RESISTOR	220	R20
R252	RESISTOR	1M	R20
R253	RESISTOR	1M	R20
R254	RESISTOR	1M	R20
R256	RESISTOR	47K	ELR20
R257	RESISTOR	47K	ELR20
R258	RESISTOR	33K	R20
R259	RESISTOR	33K	ELR20
R260	TRIMMER	10K	H0651A
R261	RESISTOR	1M	ELR20
R262	TRIMMER	10K	H0651A
R263	RESISTOR	8.2K	R20
R264	RESISTOR	47K	ELR20
R265	RESISTOR	2.2K	R20
R266	RESISTOR	12K	R20
R267	TRIMMER	4.7K	H0651A
R268	TRIMMER	47K	H0651A
R269	RESISTOR	10K	R20
R271	RESISTOR	1M	R20
R272	RESISTOR	150K	R20
R273	RESISTOR	2.2	R20
R274	RESISTOR	150	R20
R275	RESISTOR	1M	R20
R276	RESISTOR	3.3M	ELR20
R277	RESISTOR	1M	R20
R278	RESISTOR	10K	R20
R279	RESISTOR	10K	ELR20
R280	RESISTOR	4.7K	ELR20
R282	RESISTOR	100K	R20
R283	RESISTOR	10K	ELR20
R284	RESISTOR	1K	ELR20
R285	RESISTOR	10K	R20
R286	RESISTOR	10K	R20
R287	RESISTOR	4.7K	ELR20
R288	RESISTOR	100K	R20

[MAIN] UNIT

REF. NO.	DESCRIPTION	VALUE	PART NO.
C174	BARRIER	0.047	25V
C175	CERAMIC	33P	50V
C176	CERAMIC	0.0047	50V
C177	CERAMIC	0.0047	50V
C178	CERAMIC	0.0047	50V
C180	CERAMIC	47P	50V
C181	CERAMIC	0.0047	50V
C182	BARRIER	0.1	16V
C183	CERAMIC	4P	50V
C184	CERAMIC	100P	50V CH
C185	CERAMIC	100P	50V CH
C186	BARRIER	0.1	16V
C187	CERAMIC	0.0047	50V
C188	ELECTROLYTIC	4.7	25V MS7
C189	CERAMIC	0.0047	50V
C190	BARRIER	0.1	16V
C191	CERAMIC	0.001	50V
C192	ELECTROLYTIC	0.47	50V
C193	BARRIER	0.1	16V
C194	CERAMIC	0.0047	50V
C195	CERAMIC	0.0047	50V
C196	DIPMICA	30P	50V
C197	TRIMMER	CV05C1201	10P
C198	CERAMIC	0.0047	50V
C199	CERAMIC	0.0047	50V
C200	DIPMICA	47P	50V
C201	TRIMMER	CV05E3001	30P
C202	DIPMICA	39P	50V
C203	TRIMMER	CV05E3001	30P
C204	CERAMIC	0.0047	50V
C205	CERAMIC	0.0047	50V
C206	DIPMICA	47P	50V
C207	TRIMMER	CV05E3001	30P
C208	BARRIER	0.01	25V
C209	CERAMIC	220P	50V CH
C210	CERAMIC	180P	50V CH
C211	CERAMIC	47P	50V
C212	TANTALUM	3.3	16V
C213	CERAMIC	0.0047	50V
C215	ELECTROLYTIC	0.47	50V
C216	CERAMIC	0.0047	50V
C217	ELECTROLYTIC	47	10V
C219	MYLAR	0.01	50V
C220	MYLAR	0.0047	50V
C221	ELECTROLYTIC	47	10V
C222	CERAMIC	22P	50V
C223	CERAMIC	150P	50V
C224	BARRIER	0.047	25V
C225	BARRIER	0.047	25V
C226	CERAMIC	0.001	50V
C227	BARRIER	0.0047	25V
C228	MYLAR	0.0022	50V
C231	BARRIER	0.047	25V
C233	MYLAR	0.022	50V
C234	BARRIER	0.1	16V
C236	BARRIER	0.047	25V
C237	CERAMIC	0.0047	50V
C239	BARRIER	0.047	25V
C240	BARRIER	0.1	16V
C241	ELECTROLYTIC	0.22	50V HS7
C242	BARRIER	0.047	25V
C243	CERAMIC	220P	50V
C244	BARRIER	0.01	25V

[MAIN] UNIT

REF. NO.	DESCRIPTION	VALUE	PART NO.
C245	BARRIER	0.047	25V
C246	CERAMIC	330	50V
C247	BARRIER	0.047	25V
C248	BARRIER	0.047	25V
C249	BARRIER	0.047	25V
C250	CERAMIC	0.0047	50V
C251	CERAMIC	0.0047	50V
C253	BARRIER	0.1	16V
C254	ELECTROLYTIC	2.2	50V
C255	CERAMIC	220P	50V
C256	CERAMIC	220P	50V
C258	ELECTROLYTIC	1	50V MS7
C260	MYLAR	0.0047	50V
C261	CERAMIC	0.0047	50V
C262	CERAMIC	0.0047	50V
C263	ELECTROLYTIC	0.47	50V BP
C264	CERAMIC	100P	50V
C265	CERAMIC	100P	50V
C266	ELECTROLYTIC	47	10V
C267	ELECTROLYTIC	1	50V MS7
C268	ELECTROLYTIC	10	16V MS7
C269	ELECTROLYTIC	47	10V
C270	MYLAR	0.022	50V
C271	MYLAR	0.022	50V
C272	MYLAR	0.022	50V
C273	ELECTROLYTIC	47	16V
C274	BARRIER	0.1	16V
C275	ELECTROLYTIC	1	50V MS7
C276	ELECTROLYTIC	47	10V
C277	ELECTROLYTIC	0.22	50V MS7
C278	ELECTROLYTIC	1	50V MS7
C279	ELECTROLYTIC	4.7	50V
C280	CERAMIC	0.0047	50V
C281	CERAMIC	0.0047	25V
C282	MYLAR	0.022	50V
C283	ELECTROLYTIC	0.1	50 VMS7
C284	ELECTROLYTIC	47	10V
C285	ELECTROLYTIC	220	10V
C286	ELECTROLYTIC	47	16V
C287	ELECTROLYTIC	470	16V
C288	MYLAR	0.1	50V
C289	CERAMIC	220P	50V
C290	CERAMIC	220P	50V
C291	CERAMIC	100P	50V
C292	CERAMIC	0.001	50V
C293	ELECTROLYTIC	22	25V
C294	CERAMIC	100P	50V
C298	CERAMIC	0.001	50V
C299	BARRIER	0.1	16V
C300	TANTALUM	0.47	35V
C301	CERAMIC	0.001	50V
C302	CERAMIC	0.001	50V
C303	BARRIER	0.1	16V
C304	ELECTROLYTIC	47	10V
C305	BARRIER	0.1	16V
C307	ELECTROLYTIC	10	16V MS7
C308	ELECTROLYTIC	2.2	50V MS7
C309	ELECTROLYTIC	1	50V MS7
C310	BARRIER	0.0047	25V
C312	TANTALUM	0.47	35V
C313	TANTALUM	1	35V
C314	ELECTROLYTIC	220	10V

[MAIN] UNIT

REF. NO.	DESCRIPTION	VALUE	PART NO.
C315	MYLAR	0.001	50V
C316	ELECTROLYTIC	47	16V
C317	ELECTROLYTIC	22	25V
C318	ELECTROLYTIC	100	10V
C319	BARRIER	0.1	16V
C320	CERAMIC	0.0047	50V
C321	CERAMIC	0.0047	50V
C322	CERAMIC	0.0047	50V
C323	CERAMIC	0.0047	50V
C324	CERAMIC	0.0047	50V
C325	CERAMIC	0.0047	50V
C326	CERAMIC	0.0047	50V
C327	CERAMIC	0.0047	50V
C328	CERAMIC	0.0047	50V
C329	CERAMIC	120P	50V
C330	CERAMIC	15P	50V
C331	TANTALUM	10	16V
C332	ELECTROLYTIC	2.2	50V MST
C333	CERAMIC	10P	50V
C334	BARRIER	0.1	16V
C335	CERAMIC	0.0047	50V
C336	CERAMIC	0.0047	50V
C337	CERAMIC	0.0047	50V
C338	ELECTROLYTIC	1000	16V MS16
C339	ELECTROLYTIC	0.0047	50V
C340	CERAMIC	0.0047	50V
C341	CERAMIC	0.0047	50V
C342	CERAMIC	0.0047	50V
C343	CERAMIC	0.0047	50V
C344	ARRAY	B7ZC0711-32N	0.01 X 6
C345	ELECTROLYTIC	47	10V
C346	BARRIER	0.047	25V
C347	CERAMIC	0.0047	50V
C348	CERAMIC	0.001	50V
C349	CERAMIC	0.0047	50V
C351	BARRIER	0.047	25V
C352	CERAMIC	22P	50V
C353	CERAMIC	0.001	50V
C354	CERAMIC	18P	50V
C355	MYLAR	0.01	50V
C356	CERAMIC	470P	50V
C357	BARRIER	0.1	50V
C358	CERAMIC	0.001	50V
C360	BARRIER	0.1	16V
C361	TANTALUM	10	16V
C362	CERAMIC	18P	50V
C363	CERAMIC	3P	50V
C364	ELECTROLYTIC	47	10V
C365	CERAMIC	220P	50V
C366	CERAMIC	0.001	50V
C367	CERAMIC	5P	50V
RL1	RELAY		MZ-12HG
RL2	RELAY		OMR-109F
J1	CONNECTOR		TL25P-13-V1
J2	CONNECTOR		TL25P-04-V1
J3	CONNECTOR		TL25P-09-V1
J4	CONNECTOR		TL25P-06-V1
J5	CONNECTOR		TL25P-03-V1
J6	CONNECTOR		TL25P-06-V1

[MAIN] UNIT

REF. NO.	DESCRIPTION	VALUE	PART NO.
J7	CONNECTOR		TL25P-09-V1
J8	CONNECTOR		TL25P-05-V1
J9	CONNECTOR		TL25P-03-V1
J10	CONNECTOR		TL25P-05-V1
J11	CONNECTOR		TMP-J01X-A2
J12	CONNECTOR		TMP-J01X-A2
J13	CONNECTOR		JPJ2545-01-510
J14	CONNECTOR		TMP-J01X-A2
J15	CONNECTOR		JPJ2545-01-510
J16	CONNECTOR		JPJ2545-01-510
J17	CONNECTOR		TL25P-03-V1
J18	CONNECTOR		JPJ2545-01-510
J19	CONNECTOR		TL25P-05-V1
J20	CONNECTOR		TL25P-08-V1
J21	CONNECTOR		TL25P-03-V1
J22	CONNECTOR		HSJ0807-01-010
J23	CONNECTOR		TSL-P03P-B1
S2	SWITCH		SSSY12
S3	SWITCH		SSS312
W1	JUMPER		23/01/170/C21/C21
W2	JUMPER		23/02/170/C21/C21
W3	JUMPER		23/03/120/C21/C21
W4	JUMPER		23/04/120/C21/C21
W5	JUMPER		23/05/120/C21/C21
W6	JUMPER		23/06/120/C21/C21
W7	JUMPER		23/07/120/C21/C21
W8	JUMPER		23/08/085/C21/C21
W9	JUMPER		23/09/110/C21/C21
W10	JUMPER		23/00/085/C21/C21
W11	JUMPER		23/01/105/C21/C21
W12	JUMPER		23/02/090/C21/C21
W13	JUMPER		23/03/135/C21/C21
W14	JUMPER		23/04/285/C21/C21
W15	JUMPER		23/05/160/C21/C21
W16	JUMPER		23/06/300/C21/C21
W17	JUMPER		23/07/145/C21/C21
W18	JUMPER		23/08/200/C21/C21
W19	JUMPER		23/09/140/C21/C21
W20	JUMPER		23/00/130/C21/C21
W21	JUMPER		23/01/180/C21/C21
W22	JUMPER		23/02/160/C21/C21
W23	JUMPER		23/03/130/C21/C21
W24	JUMPER		23/04/100/C21/C21
W25	JUMPER		23/05/130/C21/C21
W26	JUMPER		23/06/150/C21/C21
W27	JUMPER		23/07/120/C21/C21
W28	JUMPER		IPS-1041-4
W29	JUMPER		IPS-1041-4
W30	JUMPER		23/00/085/C21/C21
W31	JUMPER		23/01/200/C21/C21
W32	JUMPER		23/02/060/C21/C21
W33	JUMPER		23/03/200/C21/C21
W34	JUMPER		23/04/170/C21/C21
W35	JUMPER		23/05/120/C21/C21
W36	JUMPER		23/06/080/C21/C21
W37	JUMPER		23/07/120/C21/C21
W38	JUMPER		23/08/060/C21/C21
W39	JUMPER		23/09/100/C21/C21
W40	JUMPER		23/00/060/C21/C21

[MAIN] UNIT

REF. NO.	DESCRIPTION	VALUE	PART NO.
R289	TRIMMER	10K	H0652A
R290	RESISTOR	10K	ELR20
R291	RESISTOR	1M	ELR20
R292	RESISTOR	10K	ELR20
R294	RESISTOR	1M	ELR20
R295	RESISTOR	10K	ELR20
R296	RESISTOR	68K	ELR20
R297	RESISTOR	4.7K	R20
R298	RESISTOR	3.3K	R20
R299	RESISTOR	15K	R20
R300	RESISTOR	4.7K	R20
R301	RESISTOR	12K	R20
R302	RESISTOR	10	R50X
R303	RESISTOR	1K	ELR25
R304	RESISTOR	3.3K	ELR20
R305	RESISTOR	10	R50X
R306	RESISTOR	1K	ELR25
R307	RESISTOR	4.7K	R20
R308	RESISTOR	47	ELR20
R309	RESISTOR	10K	ELR20
R310	RESISTOR	100K	ELR20
R311	RESISTOR	47	R20
R312	RESISTOR	8.2K	R20
R313	RESISTOR	10	R20
R314	RESISTOR	470	R25
R315	RESISTOR	470	R20
R316	RESISTOR	100	R20
R317	RESISTOR	100	R20
R318	RESISTOR	100	R20
R319	RESISTOR	100	R20
R320	RESISTOR	100	R20
R321	RESISTOR	100	R20
R323	RESISTOR	4.7K	R20
R324	RESISTOR	4.7K	R20
R325	RESISTOR	4.7K	ELR20
R326	RESISTOR	4.7K	R20
R327	RESISTOR	150	R20
R328	RESISTOR	150	R20
R330	RESISTOR	22	R25
R331	RESISTOR	1.5M	R20
R332	RESISTOR	100	R25
R333	RESISTOR	100	R20
R334	RESISTOR	22K	ELR20
R335	RESISTOR	39K	ELR20
R336	RESISTOR	2.2K	R20
R337	RESISTOR	4.7K	R20
R338	RESISTOR	1.5K	R20
R339	RESISTOR	1K	R20
R340	RESISTOR	1K	R20
R341	RESISTOR	22K	R20
R342	RESISTOR	150	ELR20
R343	RESISTOR	470	ELR20
R344	RESISTOR	12	ELR20
R345	RESISTOR	470	ELR20
R346	RESISTOR	15	ELR20
R347	RESISTOR	220	R20
R348	RESISTOR	100	R20
R349	THERMISTOR		45D26
R350	RESISTOR	100	ELR20
R351	ARRAY	2.2K	RM8
R354	RESISTOR	15K	R20
R355	RESISTOR	470K	ELR20

[MAIN] UNIT

REF. NO.	DESCRIPTION	VALUE	PART NO.
R356	RESISTOR	1M	ELR20
R357	RESISTOR	3.3K	ELR20
R358	RESISTOR	100K	R20
R359	RESISTOR	10K	ELR20
R360	RESISTOR	10K	R20
R361	TRIMMER		
R362	RESISTOR	100K	R25
R363	RESISTOR	4.7K	ELR20
R364	RESISTOR	47K	R20
R365	RESISTOR	4.7K	ELR20
R366	RESISTOR	270	R20
R367	THERMISTOR		23D29
R368	THERMISTOR		23D29
R369	RESISTOR	6.8K	ELR20
R370	RESISTOR	1K	R20
R371	RESISTOR	47K	R20
R372	RESISTOR	1K	ELR20
R373	RESISTOR	3.3K	R20
R374	RESISTOR	18K	ELR20
R375	RESISTOR	22	ELR20
R376	RESISTOR	22K	ELR20
R377	RESISTOR	3.3K	ELR20
R378	RESISTOR	100	R20
R379	RESISTOR	100	R20
R380	RESISTOR	4.7K	ELR20
R381	RESISTOR	22K	R20
R382	RESISTOR	10K	R20
R383	RESISTOR	2.2K	ELR20
R384	RESISTOR	1K	R20
C1	CERAMIC	56P	50V
C2	CERAMIC	68P	50V
C3	CERAMIC	0.0047	50V
C4	CERAMIC	100P	50V
C5	CERAMIC	0.001	50V
C6	CERAMIC	4P	50V
C7	CERAMIC	8P	50V
C8	CERAMIC	18P	50V
C9	CERAMIC	1P	50V
C11	CERAMIC	0.0047	50V
C15	CERAMIC	0.0047	50V
C16	BARRIER	0.1	16V
C19	CERAMIC	47P	50V
C20	CERAMIC	220P	50V
C21	CERAMIC	12P	50V
C22	CERAMIC	150P	50V
C23	BARRIER	0.0022	25V
C24	BARRIER	0.0033	25V
C25	BARRIER	0.1	16V
C30	CERAMIC	3P	50V
C31	CERAMIC	8P	50V
C32	CERAMIC	0.0047	50V
C33	CERAMIC	0.0047	50V
C34	CERAMIC	0.001	50V
C35	CERAMIC	0.0047	50V
C36	CERAMIC	8P	50V
C37	CERAMIC	8P	50V
C38	CERAMIC	0.0047	50V
C39	CERAMIC	470P	50V SL
C40	CERAMIC	470P	50V SL
C41	CERAMIC	6P	50V

[MAIN] UNIT

REF. NO.	DESCRIPTION	VALUE	PART NO.
C42	CERAMIC	0.001	25V
C43	CERAMIC	100P	50V
C44	CERAMIC	0.001	25V
C46	BARRIER	0.047	25V
C47	CERAMIC	0.0047	50V
C48	BARRIER	0.0012	25V
C49	BARRIER	0.0068	25V
C50	BARRIER	820P	25V
C51	BARRIER	0.015	25V
C52	BARRIER	0.0012	25V
C54	BARRIER	0.1	16V
C55	BARRIER	0.0018	25V
C56	BARRIER	0.0027	25V
C57	CERAMIC	390P	50V
C59	CERAMIC	0.0047	50V
C60	BARRIER	0.0015	25V
C61	CERAMIC	180P	50V
C62	BARRIER	0.0012	25V
C63	BARRIER	0.0015	25V
C64	BARRIER	0.015	25V
C65	BARRIER	0.001	25V
C66	BARRIER	0.047	25V
C67	CERAMIC	0.0047	50V
C68	CERAMIC	510P	50V
C69	CERAMIC	100P	50V
C70	CERAMIC	470P	50V SL
C71	BARRIER	0.0012	25V
C72	BARRIER	0.0056	25V
C73	BARRIER	820P	25V
C74	BARRIER	0.047	25V
C75	CERAMIC	0.0047	50V
C76	CERAMIC	330P	50V
C77	CERAMIC	51P	50V
C78	CERAMIC	330P	50V
C79	CERAMIC	330P	50V
C80	BARRIER	0.0027	25V
C81	CERAMIC	300P	50V
C82	BARRIER	0.0047	50V
C83	CERAMIC	0.0047	50V
C84	CERAMIC	330P	50V
C85	CERAMIC	47P	50V
C86	CERAMIC	220P	50V
C87	CERAMIC	220P	50V
C88	BARRIER	0.0018	25V
C89	CERAMIC	200P	50V
C90	BARRIER	0.047	25V
C91	CERAMIC	0.0047	50V
C92	CERAMIC	220P	50V
C93	CERAMIC	18P	50V
C94	CERAMIC	100P	50V
C95	CERAMIC	220P	50V
C96	BARRIER	0.0012	25V
C97	CERAMIC	150P	50V
C98	BARRIER	0.047	25V
C99	CERAMIC	0.0047	50V
C100	CERAMIC	33P	50V
C101	CERAMIC	120P	50V
C102	CERAMIC	39P	50V
C103	CERAMIC	68P	50V
C104	CERAMIC	120P	50V
C105	BARRIER	820P	25V
C106	CERAMIC	100P	50V

[MAIN] UNIT

REF. NO.	DESCRIPTION	VALUE	PART NO.
C107	BARRIER	0.047	25V
C108	BARRIER	0.047	25V
C109	BARRIER	0.047	25V
C110	CERAMIC	100P	50V
C111	BARRIER	0.047	25V
C112	BARRIER	0.047	25V
C114	BARRIER	0.047	25V
C115	CERAMIC	47P	50V
C116	CYLINDER	150P	50V
C117	BARRIER	0.1	16V
C118	BARRIER	0.1	16V
C119	BARRIER	0.1	16V
C120	CERAMIC	8P	50V
C121	BARRIER	0.1	16V
C122	CERAMIC	8P	50V
C123	CERAMIC	8P	50V
C124	BARRIER	0.1	16V
C125	CERAMIC	6P	50V
C126	CERAMIC	0.0047	50V
C127	CERAMIC	0.0047	50V
C128	CERAMIC	3P	50V
C130	CERAMIC	2P	50V
C131	CERAMIC	0.0047	50V
C132	BARRIER	0.1	16V
C134	BARRIER	0.1	16V
C135	CERAMIC	47P	50V
C136	CERAMIC	0.0047	50V
C137	CERAMIC	0.0047	50V
C138	CERAMIC	0.0047	50V
C139	CERAMIC	0.0047	50V
C140	CERAMIC	0.0047	50V
C141	CERAMIC	0.0047	50V
C142	ELECTROLYTIC	10	16V
C143	CERAMIC	0.0047	50V
C144	CERAMIC	0.0047	50V
C145	CERAMIC	0.0047	50V
C146	CERAMIC	0.0047	50V
C147	CERAMIC	120P	50V
C148	ELECTROLYTIC	47	10V
C149	BARRIER	0.1	16V
C150	CERAMIC	0.0047	50V
C152	CERAMIC	0.0047	50V
C153	BARRIER	0.1	16V
C154	CERAMIC	0.001	50V
C155	CERAMIC	22P	50V
C156	CERAMIC	0.0047	50V
C157	CERAMIC	0.0047	50V
C158	BARRIER	0.047	25V
C159	BARRIER	0.047	25V
C160	BARRIER	0.047	25V
C161	BARRIER	0.047	25V
C162	CERAMIC	0.001	50V
C163	CERAMIC	0.001	50V
C164	CERAMIC	0.0047	50V
C165	CERAMIC	0.0047	50V
C166	CERAMIC	0.0047	50V
C167	BARRIER	0.1	16V
C168	CERAMIC	220P	50V
C169	BARRIER	0.1	16V
C171	BARRIER	560	25V
C172	BARRIER	0.047	25V
C173	BARRIER	0.047	25V

[MAIN] UNIT

REF. NO.	DESCRIPTION	VALUE	PART NO.
W41	JUMPER		23/01/120/C21/C21
W42	JUMPER		23/02/080/C21/C21
W43	JUMPER		23/03/120/C21/C21
W44	JUMPER		23/04/100/C21/C21
W45	JUMPER		[51/04/185/W13A/W13A]
W46	JUMPER		[08 A A]
W47	JUMPER		23/07/060/C21/C21
W48	JUMPER		23/08/180/C21/C21
W49	JUMPER		23/09/070/C21/C21
W50	JUMPER		23/00/100/C21/C21
W51	JUMPER		72/99/040/X98/X98
W52	JUMPER		JPW-02A
W53	JUMPER		IPS-1041-2
W54	JUMPER		IPS-1041-4
W55	JUMPER		IPS-1041-4
W56	JUMPER		IPS-1041-4
W57	JUMPER		IPS-1041-2
W58	JUMPER		IPS-1041-2
W59	JUMPER		IPS-1041-2
W60	JUMPER		IPS-1041-4
W61	JUMPER		IPS-1041-4
W62	JUMPER		IPS-1041-4
W63	JUMPER		IPS-1041-4
W65	JUMPER		IPS-1041-4
W66	JUMPER		IPS-1041-4
W69	JUMPER		IPS-1041-4
W70	JUMPER		IPS-1041-4
W71	JUMPER		IPS-1041-4
W72	JUMPER		IPS-1041-4
W73	JUMPER		IPS-1041-2
W74	JUMPER		IPS-1041-2
W75	JUMPER		IPS-1041-2
W76	JUMPER		IPS-1041-2
W77	JUMPER		IPS-1041-2
W79	JUMPER		IPS-1041-2
W80	JUMPER		IPS-1041-2
W81	JUMPER		IPS-1041-2
W82	JUMPER		IPS-1041-4
W83	JUMPER		IPS-1041-2
W84	JUMPER		IPS-1041-2
W85	JUMPER		IPS-1041-2
W87	JUMPER		IPS-1041-2
W88	JUMPER		IPS-1041-2
W89	JUMPER		IPS-1041-2
W90	JUMPER		IPS-1041-2
W91	JUMPER		IPS-1041-4
W92	JUMPER		IPS-1041-4
W93	JUMPER		IPS-1041-2
W94	JUMPER		IPS-1041-2
W95	JUMPER		IPS-1041-2
W96	JUMPER		IPS-1041-4
W97	JUMPER		IPS-1041-4
W98	JUMPER		IPS-1041-2
W99	JUMPER		IPS-1041-4
W100	JUMPER		IPS-1041-2
W101	JUMPER		IPS-1041-2
W102	JUMPER		IPS-1041-2
W103	JUMPER		IPS-1041-4
W104	JUMPER		IPS-1041-4
W106	JUMPER		IPS-1041-4
W108	JUMPER		IPS-1041-4
W110	JUMPER		IPS-1041-2

[MAIN] UNIT

REF. NO.	DESCRIPTION	VALUE	PART NO.
W111	JUMPER		IPS-1041-2
W112	JUMPER		IPS-1041-2
W113	JUMPER		IPS-1041-2
W114	JUMPER		IPS-1041-4
W115	JUMPER		IPS-1041-2
W116	JUMPER		IPS-1041-4
W117	JUMPER		IPS-1041-2
W118	JUMPER		IPS-1041-4
W119	JUMPER		IPS-1041-2
W122	JUMPER		IPS-1041-4
W123	JUMPER		IPS-1041-4
W124	JUMPER		IPS-1041-4
W125	JUMPER		IPS-1041-4
W126	JUMPER		IPS-1041-2
W127	JUMPER		IPS-1041-2
W128	JUMPER		IPS-1041-4
W129	JUMPER		IPS-1041-2
W130	JUMPER		IPS-1041-2
W131	JUMPER		IPS-1041-4
W132	JUMPER		IPS-1041-2
W133	JUMPER		IPS-1041-4
W134	JUMPER		IPS-1041-4
W135	JUMPER		72/98/015/X98/X98

[PL] UNIT

REF. NO.	DESCRIPTION	VALUE	PART NO.
IC2	IC		μPD4001 BC
IC3	IC		μPD4001 BC
IC4	IC		μPD4001 BC
IC5	IC		μPD4069 UBC
IC6	IC		HC63A01V1C80
IC7	IC		μPD4510 BC
IC8	IC		μPD4021 BC
IC9	IC		μPD82C43C
IC10	IC		BA618
IC11	IC		DAN401
IC15	IC		μPD2834C
IC16	IC		μPB555C
IC17	IC		SN76514N
IC18	IC		μA7805C
IC19	IC		μPC1037H
IC20	IC		μPD2834C
IC21	IC		SN74LS90
IC22	IC		μPB555C
IC23	IC		HD10551
IC24	IC		SN74LS90
IC25	IC		μPC1037H
Q1	TRANSISTOR		2SA1048Y
Q2	TRANSISTOR		2SC2458GR
Q3	TRANSISTOR		2SA1048Y
Q4	TRANSISTOR		2SC2458GR
Q5	TRANSISTOR		2SC2458GR
Q6	TRANSISTOR		2SC2458GR
Q7	TRANSISTOR		2SC2458GR
Q8	TRANSISTOR		2SC2458GR
Q9	TRANSISTOR		2SC2458GR
Q10	TRANSISTOR		2SC2458GR

[PL] UNIT

REF. NO.	DESCRIPTION	VALUE	PART NO.
Q11	TRANSISTOR		2SC2458GR
Q12	TRANSISTOR		2SC2458GR
Q13	TRANSISTOR		2SC2458GR
Q14	TRANSISTOR		2SC2458GR
Q15	TRANSISTOR		2SC2458GR
Q18	TRANSISTOR		2SC2458GR
Q24	TRANSISTOR		2SA1015GR
Q25	TRANSISTOR		2SC1815GR
Q26	TRANSISTOR		2SC1571G
Q27	TRANSISTOR		2SC1571G
Q28	TRANSISTOR		2SC1571G
Q29	FET		2SK192AGR
Q30	FET		2SK192AGR
Q31	FET		2SK192AGR
Q32	FET		2SK192AGR
Q33	TRANSISTOR		2SC3399
Q34	TRANSISTOR		2SC3399
Q35	TRANSISTOR		2SC3399
Q36	TRANSISTOR		2SC3399
Q37	TRANSISTOR		2SC2668O
Q38	TRANSISTOR		2SC2668O
Q39	TRANSISTOR		2SC2668O
Q40	TRANSISTOR		2SC2668O
Q41	TRANSISTER		2SA1348
Q42	TRANSISTOR		2SC1815Y
Q43	TRANSISTOR		2SC1815Y
Q44	FET		2SK192AGR
Q45	TRANSISTOR		2SC2668O
Q46	TRANSISTOR		2SC3399
Q47	TRANSISTOR		2SC1815Y
Q48	TRANSISTOR		2SC2668O
Q49	TRANSISTOR		2SC2785EF
Q50	TRANSISTOR		2SC24258GR
Q51	TRANSISTOR		2SC2668O
Q52	TRANSISTOR		2SC3399
Q53	TRANSISTOR		2SC2458GR
Q57	TRANSISTOR		2SC1571G
Q58	TRANSISTOR		2SC2458GR
Q59	TRANSISTOR		2SC2458GR
Q60	TRANSISTOR		2SC3402
Q61	TRANSISTOR		2SC3402
Q62	TRANSISTOR		2SC2458GR
Q63	TRANSISTOR		2SC2458GR
Q64	TRANSISTOR		2SA1048Y
D1	DIODE		1SS133
D2	DIODE		1SS133
D3	DIODE		1S953
D4	DIODE		1S953
D5	DIODE		1SS133
D6	DIODE		1SS133
D7	DIODE		1SS133
D8	DIODE		1SS133
D9	DIODE		1SS133
D11	DIODE		1SS133
D12	DIODE		1SS133
D13	DIODE		1SS133
D14	DIODE		1SS133
D15	DIODE		1SS133
D16	DIODE		1SS133

[PL] UNIT

REF. NO.	DESCRIPTION	VALUE	PART NO.
D17	ZENER		RD3.0E B2
D18	ZENER		RD5.1E B2
D19	DIODE		1S953
D20	DIODE		1SS133
D21	DIODE		1SS133
D22	DIODE		1SS133
D23	DIODE		1SS133
D24	DIODE		1SS133
D25	DIODE		1SS133
D26	DIODE		1SS133
D27	DIODE		1SS133
D28	DIODE		1SS133
D29	DIODE		1SS133
D30	DIODE		1SS133
D31	DIODE		1SS133
D32	DIODE		1SS133
D33	DIODE		1SS53
D34	DIODE		1SS53
D35	DIODE		1SS133
D36	DIODE		1SS133
D37	DIODE		1SS133
D38	DIODE		1SS133
D39	DIODE		1SS133
D40	DIODE		1SS133
D41	DIODE		1SS133
D42	DIODE		1SS133
D43	DIODE		1SS133
D44	DIODE		1SS133
D45	DIODE		1SS133
D46	DIODE		1SS133
D47	DIODE		1SS133
D48	DIODE		1SS133
D49	DIODE		1SS133
D50	DIODE		1SS133
D51	DIODE		1SS133
D52	DIODE		1SS133
D53	DIODE		1SS133
D54	DIODE		1SS133
D55	DIODE		1SS133
D56	DIODE		1SS133
D57	DIODE		1SS133
D58	DIODE		1SS133
D59	DIODE		1SS133
D60	DIODE		1SS133
D61	DIODE		1SS133
D62	DIODE		1SS133
D63	DIODE		1SS133
D64	DIODE		1SS133
D65	DIODE		1SS133
D66	DIODE		1SS133
D67	DIODE		1SS133
D68	DIODE		1SS133
D69	DIODE		1SS133
D73	DIODE		1SS53
D74	VARICAP		1SV50E
D75	VARICAP		1SV50E
D76	VARICAP		1SV50E
D77	VARICAP		1SV50E
D78	DIODE		1SS53
D79	DIODE		1SS53
D80	DIODE		1SS53
D82	DIODE		1SS53

[PL] UNIT

REF. NO.	DESCRIPTION	VALUE	PART NO.
D83	DIODE		1SS53
D84	DIODE		1SS53
D85	DIODE		1SS53
D86	DIODE		1SS53
D87	VARICAP		1SV50E
D88	VARICAP		1SV50E(1)
D89	DIODE		1SS53
D90	DIODE		1SS133
D91	DIODE		1SS133
D94	DIODE		1SS211
D95	DIODE		1SS211
D96	DIODE		1SS99
X1	CERAMIC RESONATOR		CSA4.91MG
X2	CRYSTAL		CR140 HC43/U12.800
X3	CRYSTAL		CR139 HC43/U11.520
L1	COIL	101K	LAL04NA
L2	COIL	101K	LAL04NA
L3	COIL	101K	LAL04NA
L4	COIL	101K	LAL04NA
L5	COIL	101K	LAL04NA
L6	COIL	101K	LAL04NA
L7	COIL		BT01RN1-A61
L8	COIL	101K	LAL04NA
L9	COIL	101K	LAL03NA
L10	COIL		BT01RN1-A61
L11	COIL	101K	FL5H
L12	COIL		LR-79
L13	COIL		LB-135
L14	COIL		LB-79
L15	COIL		LB-135
L16	COIL		LR-79
L17	COIL		LB-135
L18	COIL		LR-79
L19	COIL		LB-135
L20	COIL		LW-25
L21	COIL		LW-25
L22	COIL		LW-25
L23	COIL		LW-25
L25	COIL	R56M	LAL03NA
L26	COIL		LA-236
L27	COIL		LA-236
L28	COIL		LA-245
L30	COIL	R27M	LAL03NA
L31	COIL		LA-242
L32	COIL		LA-253
L33	COIL		LA-247
L34	COIL		LA-245
L35	COIL		LA-232
L36	COIL		LA-243
L37	COIL		LR-87
L38	COIL	101K	LAL03NA
L39	COIL		LS-161
L40	COIL		LS-161
L41	COIL		LS-161
L42	COIL		LA-266
L43	COIL		LS-161
L44	COIL		LS-161
L45	COIL	101K	LAL03NA
L46	COIL	101K	LAL03NA
L47	COIL		LA-246

[PL] UNIT

REF. NO.	DESCRIPTION	VALUE	PART NO.
L48	COIL		LW-25
L49	COIL	101K	LAL03NA
L50	COIL	101K	LAL03NA
L51	COIL	100K	LAL03NA
L52	COIL	100K	LAL03NA
L53	COIL		LS-93
L54	COIL		LS-165
L55	COIL		LS-165
L56	COIL	1R2M	LAL03NA
L57	COIL		LS-284
L58	COIL		LS-284
L59	COIL		LS-284
L60	COIL		LS-114
L61	COIL	6R8K	LAL03NA
L62	COIL	101K	FL5H
L63	COIL	R27M	LAL03NA
L64	COIL		LA-246
L65	COIL		LA-254
L66	COIL	102K	LAL04NA
L66	COIL	101K	LAL03NA
L69	COIL	100K	LAL03NA
L71	COIL		BT01RN1-A61
L72	COIL		BT01RN1-A61
L73	COIL		BT01RN1-A61
L74	COIL		BT01RN1-A61
L75	COIL		BT01RN1-A61
L76	COIL		BT01RN1-A61
L77	COIL		BT01RN1-A61
L78	COIL		BT01RN1-A61
L79	COIL		BT01RN1-A61
L80	COIL		BT01RN1-A61
L81	COIL		BT01RN1-A61
L82	COIL		BT01RN1-A61
L83	COIL		BT01RN1-A61
L84	COIL		BT01RN1-A61
L85	COIL		BT01RN1-A61
L86	COIL	101K	LAL03NA
L87	COIL	101K	LAL03NA
L88	COIL	101K	LAL03NA
L89	COIL	101K	LAL03NA
L90	COIL	101K	LAL03NA
L91	COIL	101K	LAL03NA
L92	COIL		FSOH050RN01
L93	COIL		LR-165
L94	COIL	101K	LAL03NA
L95	COIL		BT01RN1-A61
L96	COIL	101K	LAL03NA
R1	RESISTOR	10K	R20
R2	RESISTOR	10K	R20
R7	RESISTOR	47K	R20
R8	RESISTOR	2.2K	R20
R9	RESISTOR	4.7K	ELR20
R10	RESISTOR	47K	ELR20
R11	RESISTOR	47K	ELR20
R12	RESISTOR	47K	R20
R13	RESISTOR	47K	R20
R14	RESISTOR	47K	R20
R15	RESISTOR	47K	R20
R16	RESISTOR	10K	ELR20
R17	RESISTOR	3.3M	ELR25
R18	RESISTOR	47K	ELR20

[PL] UNIT

REF. NO.	DESCRIPTION	VALUE	PART NO.
R19	RESISTOR	10K	ELR20
R20	RESISTOR	47K	ELR20
R21	RESISTOR	10K	ELR20
R22	RESISTOR	47K	ELR20
R23	RESISTOR	800K	CRB25 FX
R24	RESISTOR	400K	CRB25 DX
R25	RESISTOR	200K	CRB25 DX
R26	RESISTOR	100K	CRB25 DX
R27	RESISTOR	470K	ELR20
R28	RESISTOR	47K	R20
R29	RESISTOR	1K	R20
R30	RESISTOR	1M	ELR20
R31	RESISTOR	47K	ELR20
R32	RESISTOR	270	R20
R33	RESISTOR	1.5K	R20
R34	RESISTOR	47K	R20
R35	RESISTOR	47K	R20
R36	RESISTOR	47K	R20
R37	RESISTOR	47K	R20
R38	RESISTOR	47K	R20
R39	RESISTOR	47K	R20
R40	RESISTOR	47K	R20
R41	RESISTOR	47K	R20
R42	RESISTOR	100K	ELR20
R43	RESISTOR	47K	R20
R44	RESISTOR	47K	ELR20
R45	RESISTOR	47K	ELR20
R46	RESISTOR	10K	R20
R47	RESISTOR	1K	R20
R48	RESISTOR	47K	ELR20
R49	RESISTOR	47K	R25
R50	RESISTOR	120K	R20
R52	ARRAY	10K	RM-4
R53	ARRAY	10K	RM-8
R56	RESISTOR	1K	R25
R57	RESISTOR	1K	R25
R58	RESISTOR	1K	R25
R59	RESISTOR	1K	R25
R60	RESISTOR	1K	R25
R61	RESISTOR	1K	R25
R62	RESISTOR	10K	CRB25 FX
R63	RESISTOR	750	CRB25 FX
R64	RESISTOR	1.8K	CRB25 FX
R65	RESISTOR	3.3K	CRB25 FX
R66	RESISTOR	5.6K	CRB25 FX
R67	RESISTOR	4.7K	CRB25 FX
R68	RESISTOR	1K	ELR20
R69	RESISTOR	1K	ELR20
R70	RESISTOR	1K	ELR20
R71	RESISTOR	1K	ELR20
R72	RESISTOR	1K	ELR20
R73	RESISTOR	1K	ELR20
R74	RESISTOR	1K	R20
R75	RESISTOR	1K	R20
R76	RESISTOR	1K	R20
R77	RESISTOR	1K	R20
R78	RESISTOR	1K	R20
R79	RESISTOR	1K	R20
R80	RESISTOR	1K	R20
R81	RESISTOR	1K	R20
R82	RESISTOR	1K	R20
R83	RESISTOR	47K	R20

[PL] UNIT

REF. NO.	DESCRIPTION	VALUE	PART NO.
R84	RESISTOR	47K	ELR20
R85	RESISTOR	4.7K	ELR20
R86	RESISTOR	2.7K	R20
R87	RESISTOR	10K	R20
R96	RESISTOR	1K	R25
R97	RESISTOR	1K	R25
R98	RESISTOR	1K	R25
R100	RESISTOR	47K	R20
R101	RESISTOR	22K	ELR20
R102	RESISTOR	47K	ELR20
R103	RESISTOR	47K	ELR20
R104	RESISTOR	4.7K	R20
R105	RESISTOR	220K	R20
R106	RESISTOR	22K	ELR20
R107	RESISTOR	1K	ELR20
R108	RESISTOR	1K	R25
R109	RESISTOR	47	R20
R110	RESISTOR	100K	ELR20
R111	RESISTOR	100K	ELR20
R112	RESISTOR	100K	R20
R113	RESISTOR	100K	ELR20
R114	RESISTOR	100K	ELR20
R115	RESISTOR	100K	ELR20
R116	RESISTOR	100K	ELR20
R117	RESISTOR	100K	ELR20
R118	RESISTOR	150	ELR20
R119	RESISTOR	3.3K	ELR20
R120	RESISTOR	150	ELR20
R121	RESISTOR	3.3K	R20
R122	RESISTOR	150	R20
R123	RESISTOR	3.3K	R20
R124	RESISTOR	150	R20
R125	RESISTOR	3.3K	R20
R126	RESISTOR	180	ELR20
R127	RESISTOR	180	ELR20
R128	RESISTOR	180	ELR20
R129	RESISTOR	180	R25
R134	RESISTOR	220	ELR20
R135	RESISTOR	4.7K	R20
R136	RESISTOR	330	ELR20
R137	RESISTOR	22	ELR20
R138	RESISTOR	100	ELR20
R139	RESISTOR	22K	R20
R140	RESISTOR	10K	ELR20
R141	RESISTOR	220	R20
R142	RESISTOR	22	ELR20
R143	RESISTOR	820	R20
R144	RESISTOR	100	ELR20
R145	RESISTOR	22K	ELR20
R146	RESISTOR	10K	ELR20
R147	RESISTOR	220	ELR20
R148	RESISTOR	4.7K	ELR20
R149	RESISTOR	1K	ELR20
R150	RESISTOR	1K	ELR20
R151	RESISTOR	100	R20
R152	RESISTOR	1K	R20
R153	RESISTOR	1K	R20
R154	RESISTOR	100	R25
R155	RESISTOR	4.7K	ELR20
R157	RESISTOR	100	R20
R158	RESISTOR	10K	ELR20
R159	RESISTOR	2.7K	ELR20

[PL] UNIT

REF. NO.	DESCRIPTION	VALUE	PART NO.
R160	RESISTOR	4.7K	R20
R162	RESISTOR	3.3K	ELR20
R163	RESISTOR	3.3K	R20
R164	RESISTOR	470	R20
R167	RESISTOR	10K	ELR20
R169	RESISTOR	220	ELR20
R170	RESISTOR	680	ELR20
R171	RESISTOR	47K	ELR20
R172	RESISTOR	100	ELR20
R173	RESISTOR	22K	ELR20
R174	RESISTOR	15K	ELR20
R175	RESISTOR	33K	R20
R176	RESISTOR	1.5K	ELR20
R177	RESISTOR	470	R20
R178	RESISTOR	1K	R20
R179	RESISTOR	1K	R25
R180	RESISTOR	1K	R25
R182	RESISTOR	100	R25
R183	RESISTOR	10K	R20
R184	RESISTOR	15K	R20
R185	RESISTOR	10K	R20
R186	RESISTOR	1K	ELR20
R187	RESISTOR	1K	R20
R188	RESISTOR	100K	R20
R190	RESISTOR	1K	R20
R191	RESISTOR	220	R20
R192	RESISTOR	150	R20
R193	RESISTOR	4.7K	R20
R194	RESISTOR	330	R20
R195	RESISTOR	2.2K	ELR20
R196	RESISTOR	270	ELR20
R199	RESISTOR	100K	ELR20
R200	RESISTOR	22K	ELR20
R201	TRIMMER	100K	H0651A
R202	RESISTOR	10K	R20
R203	RESISTOR	470K	ELR20
R204	RESISTOR	10K	ELR20
R205	RESISTOR	33K	R20
R206	RESISTOR	1.5K	R20
R207	RESISTOR	100	R20
R208	RESISTOR	68	ELR20
R209	RESISTOR	2.7K	ELR20
R212	RESISTOR	4.7K	ELR20
R213	RESISTOR	270	R25
R214	RESISTOR	22K	R20
R215	RESISTOR	22K	R20
R216	RESISTOR	220	R20
R217	RESISTOR	47K	ELR20
R218	RESISTOR	100	ELR20
R219	RESISTOR	33	R20
R220	RESISTOR	1K	R25
R221	RESISTOR	4.7K	R20
R222	RESISTOR	4.7K	R20
R223	RESISTOR	22	ELR20
R224	RESISTOR	100	R20
R225	RESISTOR	10K	ELR20
R226	RESISTOR		SRW1P10-J
R227	RESISTOR	22K	ELR20
R229	RESISTOR	10K	ELR20
R232	RESISTOR	1K	ELR20
R233	RESISTOR	4.7K	R20
R234	RESISTOR	1K	ELR20
R235	RESISTOR	100K	ELR20

[PL] UNIT

REF. NO.	DESCRIPTION	VALUE	PART NO.
R236	RESISTOR	1K	ELR20
R237	RESISTOR	47	R20
R238	RESISTOR	22K	ELR20
R239	RESISTOR	10K	ELR20
R240	RESISTOR	1K	R20
R241	RESISTOR	100K	ELR20
R242	RESISTOR	1.5K	ELR20
R243	RESISTOR	1K	ELR20
R244	TRIMMER	330	H0652A
R245	RESISTOR	22K	R20
R246	TRIMMER	10K	H0652A
R247	RESISTOR	470	R20
R248	RESISTOR	470	ELR20
R249	RESISTOR	10K	R20
R250	RESISTOR	220K	R20
R251	RESISTOR	1K	ELR20
R253	RESISTOR	100	R20
R254	RESISTOR	47K	R20
R255	RESISTOR	100K	R20
R256	RESISTOR	2.7K	R20
R257	RESISTOR	27K	ELR20
R258	RESISTOR	4.7K	R20
R259	RESISTOR	100	R20
R261	RESISTOR	22	R20
R262	RESISTOR	10K	ELR20
R263	RESISTOR	270	ELR20
R264	RESISTOR	18	ELR20
R265	RESISTOR	270	ELR20
R266	RESISTOR	1M	R20
R267	RESISTOR	1M	ELR20
R268	RESISTOR	10K	ELR20
R269	RESISTOR	47K	R25
R270	RESISTOR	3.3K	R20
C1	CERAMIC	0.001	50V
C2	CERAMIC	0.001	50V
C3	CERAMIC	0.001	50V
C4	CERAMIC	0.001	50V
C5	CERAMIC	100P	50V
C6	ELECTROL	0.47	50V
C7	ELECTROL	1	50V
C8	ELECTROL	1	50V
C9	ELECTROL	0.47	50V
C10	CERAMIC	30P	50V
C11	CERAMIC	30P	50V
C13	ARRAY	B7ZC0711-32N	0.01 X 6
C14	ARRAY	B8XC0114-32N	0.001 X 7
C15	CERAMIC	0.001	50V
C16	ARRAY	B7ZC0711-32N	0.01 X 6
C17	CERAMIC	0.001	50V
C18	CERAMIC	0.001	50V
C19	CERAMIC	0.0047	50V
C20	CERAMIC	0.0047	50V
C21	CERAMIC	47P	50V
C23	CERAMIC	470P	50V
C24	CERAMIC	470P	50V
C25	CERAMIC	470P	50V
C26	CERAMIC	0.0047	50V
C27	ELECTROLYTIC	47	10V
C28	CERAMIC	0.0047	50V
C29	CERAMIC	0.001	50V
C30	MYLAR	0.1	50V
C31	CERAMIC	0.0047	50V

[PL] UNIT

REF. NO.	DESCRIPTION	VALUE	PART NO.
C32	ELECTROLYTIC	100	10V
C33	BARRIER	0.047	25V
C34	BARRIER	0.047	25V
C35	CERAMIC	100P	50V CH
C36	CERAMIC	22P	50V CH
C37	TRIMMER	CTZ51C	10P
C38	CERAMIC	68P	50V CH
C39	ELECTROLYTIC	100	25V
C40	CERAMIC	12P	50V CH
C41	CERAMIC	12P	50V CH
C42	CERAMIC	0.0047	50V
C43	CERAMIC	68P	50V CH
C44	CERAMIC	12P	50V CH
C45	TRIMMER	CTZ51C	10P
C46	CERAMIC	47P	50V CH
C47	CERAMIC	12P	50V CH
C48	CERAMIC	12P	50V CH
C49	CERAMIC	0.0047	50V
C50	CERAMIC	51P	50V CH
C51	CERAMIC	10P	50V CH
C52	TRIMMER	CTZ51A	6P
C53	CERAMIC	47P	50V CH
C54	CERAMIC	12P	50V CH
C55	CERAMIC	8P	50V CH
C56	CERAMIC	0.0047	50V
C57	CERAMIC	39P	50V CH
C58	CERAMIC	8P	50V CH
C59	TRIMMER	CTZ51A	6P
C60	CERAMIC	33P	50V CH
C61	CERAMIC	12P	50V CH
C62	CERAMIC	3P	50V CH
C63	CERAMIC	0.0047	50V
C64	CERAMIC	0.0047	50V
C65	CERAMIC	1P	50V
C66	CERAMIC	0.0047	50V
C67	CERAMIC	1P	50V
C68	CERAMIC	0.0047	50V
C69	CERAMIC	1P	50V
C70	CERAMIC	0.0047	50V
C71	CERAMIC	1P	50V
C72	CERAMIC	0.001	50V
C73	CERAMIC	0.001	50V
C74	CERAMIC	0.001	50V
C75	CERAMIC	0.001	50V
C76	CERAMIC	0.001	50V
C77	CERAMIC	22P	50V
C78	CERAMIC	100P	50V
C79	CERAMIC	0.001	50V
C80	CERAMIC	0.001	50V
C81	CERAMIC	220P	50V
C82	CERAMIC	18P	50V
C83	CERAMIC	10P	50V
C84	CERAMIC	39P	50V
C85	CERAMIC	39P	50V
C86	CERAMIC	27P	50V
C87	CERAMIC	0.0047	50V
C88	ELECTROLYTIC	100	10V
C89	ELECTROLYTIC	0.47	50V
C90	CERAMIC	0.0047	50V
C91	CERAMIC	100P	50V
C92	CERAMIC	0.0047	50V
C93	CERAMIC	0.001	50V
C94	CERAMIC	10P	50V

[PL] UNIT

REF. NO.	DESCRIPTION	VALUE	PART NO.
C95	CERAMIC	0.001	50V
C96	CERAMIC	51P	50V
C97	CERAMIC	15P	50V
C98	CERAMIC	33P	50V
C99	CERAMIC	51P	50V
C100	CERAMIC	47P	50V
C101	CERAMIC	24P	50V
C102	CERAMIC	15P	50V
C103	CERAMIC	27P	50V
C104	CERAMIC	75P	50V
C105	CERAMIC	18P	50V
C106	CERAMIC	0.001	50V
C107	CERAMIC	0.001	50V
C108	CERAMIC	43P	50V
C109	CERAMIC	12P	50V
C110	CERAMIC	22P	50V
C111	CERAMIC	39P	50V
C112	CERAMIC	39P	50V
C113	CERAMIC	0.0047	50V
C114	CERAMIC	0.0047	50V
C116	CERAMIC	0.0047	50V
C118	CERAMIC	0.0047	50V
C119	CERAMIC	0.0047	50V
C120	CERAMIC	0.0047	50V
C121	CERAMIC	100P	50V
C122	CERAMIC	5P	50V
C123	BARRIER	0.35P	50V
C124	CERAMIC	5P	50V
C125	CERAMIC	0.0047	50V
C126	CERAMIC	0.0047	50V
C127	CERAMIC	0.0047	50V
C128	CERAMIC	56P	50V
C129	CERAMIC	56P	50V
C130	ELECTROLYTIC	0.22	50V MS7
C132	ELECTROLYTIC	10	16V
C133	CERAMIC	0.001	50V
C134	CERAMIC	150P	50V
C135	CERAMIC	0.0047	50V
C136	CERAMIC	0.001	50V
C137	CERAMIC	0.0047	50V
C138	TRIMMER	CTZ51A	6P
C139	CERAMIC	24P	50V CH
C140	CERAMIC	100P	50V CH
C141	CERAMIC	100P	50V CH
C142	CERAMIC	47P	50V
C143	CERAMIC	0.0047	50V
C144	CERAMIC	0.5P	50V
C145	CERAMIC	0.0047	50V
C146	CERAMIC	470P	50V
C147	CERAMIC	470P	50V
C148	CERAMIC	470P	50V
C149	MYLAR	0.1	50V
C150	MYLAR	0.022	50V
C151	CERAMIC	0.001	50V
C152	CERAMIC	0.001	50V
C153	ELECTROLYTIC	47	10V
C154	CERAMIC	22P	50V CH
C155	CERAMIC	22P	50V CH
C156	CERAMIC	0.001	50V
C157	CERAMIC	4P	50V CH
C158	CERAMIC	4P	50V CH
C161	CERAMIC	0.001	50V
C162	CERAMIC	0.001	50V

[PL] UNIT

REF. NO.	DESCRIPTION	VALUE	PART NO.
C163	ELECTROLYTIC	47	10V
C164	CERAMIC	0.0047	50V
C165	CERAMIC	0.001	50V
C166	CERAMIC	100P	50V
C168	CERAMIC	470P	50V
C169	CERAMIC	68P	50V
C170	CERAMIC	27P	50V
C171	CERAMIC	470P	50V SL
C172	BARRIER	RAU08SA	50 680P
C173	CERAMIC	470P	50V SL
C174	CERAMIC	0.0047	50V
C175	CERAMIC	0.0047	50V
C176	CERAMIC	0.0047	50V
C177	CERAMIC	100P	50V CH
C178	CERAMIC	100P	50V CH
C179	CERAMIC	51P	50V CH
C180	CERAMIC	0.0047	50V
C181	CERAMIC	0.5P	50V
C182	CERAMIC	56P	50V CH
C183	CERAMIC	56P	50V
C184	CERAMIC	56P	50V
C185	CERAMIC	8P	50V
C186	CERAMIC	15P	50V
C187	CERAMIC	0.0047	50V
C189	CERAMIC	0.0047	50V
C190	CERAMIC	8P	50V
C191	CERAMIC	8P	50V
C192	CERAMIC	0.5P	50V
C193	CERAMIC	8P	50V
C194	CERAMIC	47P	50V
C196	CERAMIC	0.001	50V
C197	CERAMIC	0.0047	50V
C198	CERAMIC	8P	50V
C199	CERAMIC	1P	50V
C200	CERAMIC	8P	50V
C201	CERAMIC	0.0047	50V
C202	CERAMIC	47P	50V
C204	BARRIER	0.1	16V
C205	CERAMIC	5P	50V
C206	CERAMIC	0.0047	50V
C207	ELECTROLYTIC	47	10V
C208	ELECTROLYTIC	47	10V
C209	ELECTROLYTIC	47	10V
C210	ELECTROLYTIC	47	10V
C211	CERAMIC	0.0022	50V
C212	CERAMIC	270P	50V
C213	CERAMIC	0.0047	50V
C214	ELECTROLYTIC	47	10V
C215	ELECTROLYTIC	10	16V
C216	CERAMIC	0.0047	50V
C217	ELECTROLYTIC	47	10V
C218	CERAMIC	0.0047	50V
C219	ELECTROLYTIC	10	16V
C220	CERAMIC	20P	50V
C221	CERAMIC	15P	50V
C222	CERAMIC	22P	50V
C223	CERAMIC	68P	50V
C224	CERAMIC	15P	50V
C225	ELECTROLYTIC	47	10V
C226	CERAMIC	0.0047	50V
C227	ELECTROLYTIC	47	10V
C228	BARRIER	0.1	16V

[PL] UNIT

REF. NO.	DESCRIPTION	VALUE	PART NO.
C229	CERAMIC	0.0047	50V
C230	ELECTROLYTIC	10	16V
C231	ELECTROLYTIC	100	10V
C232	MYLAR	0.047	50V
C233	ELECTROLYTIC	0.47	50V BP
C234	CERAMIC	0.0047	50V
C235	MYLAR	0.0047	50V
C236	ELECTROLYTIC	100	10V
C237	BARRIER	0.1	16V
C238	BARRIER	0.1	16V
C239	ELECTROLYTIC	4.7	25V BP
C240	ELECTROLYTIC	4.7	25V BP
C241	ELECTROLYTIC	3.3	50V
C242	BARRIER	0.047	25V
C243	ELECTROLYTIC	100	10V
C244	ELECTROLYTIC	4.7	25V BP
C245	CERAMIC	0.0047	50V
C246	ARRAY	B5RC0124-32N	0.001 X 4
C247	ARRAY	B8XC0114-32N	0.001 X 7
C249	CERAMIC	0.0047	50V
C250	CERAMIC	0.0047	50V
C251	CERAMIC	82P	50V CH
C252	CERAMIC	8P	50V CH
C254	BARRIER	0.1	16V
C255	CERAMIC	0.001	50V
C258	CERAMIC	0.0047	50V
C259	CERAMIC	0.0047	50V
C260	BARRIER	0.01	25V
C261	BARRIER	0.1	16V
C262	ELECTROLYTIC	100	10V
C263	CERAMIC	0.0047	50V
C264	CERAMIC	0.001	50V
C265	ELECTROLYTIC	10	16V MS7
J1	CONNECTOR		TL25P-06-V1
J2	CONNECTOR		TL25P-03-V1
J3	CONNECTOR		HSJ0807-01-010
J4	CONNECTOR		TL25P-07-V1
J5	CONNECTOR		TL25P-08-V1
J6	CONNECTOR		TL25P-06-V1
J7	CONNECTOR		TL25P-06-V1
J8	CONNECTOR		TL25P-09-V1
J9	CONNECTOR		TL25P-07-V1
J10	CONNECTOR		TL25P-06-V1
J11	CONNECTOR		TL25P-04-V1
J12	CONNECTOR		TL25P-03-V1
J13	CONNECTOR		TMP-J01X-A2
J14	CONNECTOR		TMP-J01X-A2
J15	CONNECTOR		TL25P-03-V1
J16	CONNECTOR		TL25P-04-V1
J17	CONNECTOR		TL25P-10-V1
J18	CONNECTOR		HLJ4306-01-3080
J19	CONNECTOR		TCS4470-01-1111
J20	CONNECTOR		TCS4480-01-1111
J21	CONNECTOR		IMSA-9201B-2-4T
J22	CONNECTOR		IMSA-9201B-2-12T
J23	CONNECTOR		TL25P-03-V1
J24	CONNECTOR		TL25P-03-V1
P1	CONNECTOR		IMSA-9201B-HT
P2	CONNECTOR		IMSA-9201B-HT
P3	CONNECTOR		IMSA-9201B-HT

[PL] UNIT

REF. NO.	DESCRIPTION	VALUE	PART NO.
P4	CONNECTOR		IMSA-9201B-HT
P5	CONNECTOR		IMSA-9201B-HT
S1	SWITCH		SSS312
S2	SWITCH		SSS312
BT1	LITHIUM		BR2032-1T2
W2	JUMPER		IPS-1041-1
W3	JUMPER		IPS-1041-4
W4	JUMPER		IPS-1041-2
W5	JUMPER		IPS-1041-4
W8	JUMPER		IPS-1041-2
W10	JUMPER		IPS-1041-4
W11	JUMPER		IPS-1041-4
W12	JUMPER		IPS-1041-2
W14	JUMPER		IPS-1041-4
W15	JUMPER		IPS-1041-4
W17	JUMPER		IPS-1041-4
W19	JUMPER		IPS-1041-4
W20	JUMPER		IPS-1041-4
W21	JUMPER		IPS-1041-4
W22	JUMPER		IPS-1041-4
W23	JUMPER		IPS-1041-2
W24	JUMPER		IPS-1041-2
W25	JUMPER		IPS-1041-2
W26	JUMPER		JPW-02H
W27	JUMPER		JPW-02H
W28	JUMPER		IPS-1041-4
W29	JUMPER		IPS-1041-4
W30	JUMPER		IPS-1041-4
W31	JUMPER		IPS-1041-4
W32	JUMPER		IPS-1041-2
W33	JUMPER		JPW-02A
W34	JUMPER		IPS-1041-4
W35	JUMPER		IPS-1041-4
W36	JUMPER		IPS-1041-4
W37	JUMPER		IPS-1041-4
W38	JUMPER		IPS-1041-2
W39	JUMPER		IPS-1041-2
W40	JUMPER		IPS-1041-4
W41	JUMPER		IPS-1041-4
W42	JUMPER		IPS-1041-4
W43	JUMPER		IPS-1041-2
W44	JUMPER		IPS-1041-4
W45	JUMPER		IPS-1041-4
W46	JUMPER		IPS-1041-4
W47	JUMPER		IPS-1041-2
W48	JUMPER		IPS-1041-2
W49	JUMPER		IPS-1041-2
W50	JUMPER		IPS-1041-4
W51	JUMPER		IPS-1041-2
W52	JUMPER		IPS-1041-4
W53	JUMPER		IPS-1041-4
W54	JUMPER		IPS-1041-2
W55	JUMPER		IPS-1041-2
W56	JUMPER		IPS-1041-2
W57	JUMPER		IPS-1041-2
W58	JUMPER		IPS-1041-4
W59	JUMPER		IPS-1041-2

[PL] UNIT

REF. NO.	DESCRIPTION	VALUE	PART NO.
W60	JUMPER		IPS-1041-4
W61	JUMPER		IPS-1041-2
W62	JUMPER		IPS-1041-2
W63	JUMPER		IPS-1041-4
W64	JUMPER		IPS-1041-2
W65	JUMPER		IPS-1041-4
W66	JUMPER		IPS-1041-4
W67	JUMPER		IPS-1041-4
W68	JUMPER		IPS-1041-4
W69	JUMPER		IPS-1041-4
W70	JUMPER		IPS-1041-2
W71	JUMPER		IPS-1041-2
W72	JUMPER		JPW-02H
W73	JUMPER		IPS-1041-2
W74	JUMPER		IPS-1041-4
W76	JUMPER		IPS-1041-2
W77	JUMPER		IPS-1041-4
W78	JUMPER		IPS-1041-4
W79	JUMPER		IPS-1041-4
W80	JUMPER		IPS-1041-2
W81	JUMPER		IPS-1041-2
W82	JUMPER		IPS-1041-4
W83	JUMPER		IPS-1041-4
W84	JUMPER		IPS-1041-2
W85	JUMPER		IPS-1041-4
W87	JUMPER		IPS-1041-4
W89	JUMPER		IPS-1041-4
W90	JUMPER		IPS-1041-4
W91	JUMPER		IPS-1041-4
W92	JUMPER		IPS-1041-4
W93	JUMPER		IPS-1041-4
W94	JUMPER		IPS-1041-4
W95	JUMPER		IPS-1041-2
W96	JUMPER		IPS-1041-2
W97	JUMPER		IPS-1041-4
W100			[61/99/85/W13A/W13A]
W101			[08 A A]
W102			[66/99/135/W11A/W11A]
W103			[08 A A]
W104			[51/02/170/W13A/W13A]
W105			[08 A A]
W106			23/05/300/C21/C21
W107			23/03/85/C21/C21
W108			23/03/150/C21/C21
W109			23/02/160/C21/C21
W110			[66/99/65/W11A/W11A]
W111			[08 A A]
W112			23/01/210/C21/C21
W113			23/01/175/C21/C21
W115			23/04/170/C21/C21
W117			23/04/110/C21/C21
W118			23/03/110/C21/C21
W119			23/02/110/C21/C21
W120			23/01/110/C21/C21
W121			23/04/150/C21/C21
W122			23/07/200/C21/C21
W123			23/08/170/C21/C21
W124			23/04/130/C21/C21
W125			23/04/210/C21/C21
W126			23/05/220/C21/C21
W127			23/06/165/C21/C21
W128			23/07/130/C21/C21

[PL] UNIT

REF. NO.	DESCRIPTION	VALUE	PART NO.
W129			23/08/135/C21/C21
W130			23/03/270/C21/C21
W131			61/99/220/W13A/W13A
W132			08 A A
W133	JUMPER		IPS-1041-2
W134	JUMPER		IPS-1041-2
W135	JUMPER		IPS-1041-2
W136	JUMPER		IPS-1041-2
W137	JUMPER		JPW-02A
W138	JUMPER		JPW-02A
W139	JUMPER		IPS-1041-4
W140	JUMPER		IPS-1041-4
W141	JUMPER		IPS-1041-4
W142	JUMPER		IPS-1041-2
W143	JUMPER		IPS-1041-2
W144	JUMPER		74/98/032/X98/X98
W145	JUMPER		74/98/018/X98/X98
W149	JUMPER		IPS-1041-4
W150	JUMPER		IPS-1041-4
W151	JUMPER		IPS-1041-4
W152	JUMPER		JPW-02A
W153	JUMPER		IPS-1041-2
W154	JUMPER		IPS-1041-4

[PA] UNIT (POWER AMPLIFIER)

REF. NO.	DESCRIPTION	VALUE	PART NO.
Q1	TRANSISTOR		2SC1971
Q2	TRANSISTOR		2SC3133
Q3	TRANSISTOR		2SC3133
Q4	TRANSISTOR		2SD880Y
Q5	TRANSISTOR		2SC2904
Q6	TRANSISTOR		2SC2904
Q8	TRANSISTOR		2SA1015
Q9	TRANSISTOR		2SC1815
D1	DIODE		MV5
D2	DIODE		MV5
D3	DIODE		MV5
D4	DIODE		15CD11
D5	DIODE		1N4002
D6	DIODE		1SS53
D16	DIODE		1SS133
L1	COIL		LR-142
L2	COIL		BT01RN1-A61
L3	COIL		BT01RN1-A61
L4	COIL		LR-155
L5	COIL		FSQH050RN
L6	COIL		FSQH050RN
L7	COIL		FSQH050RN
L8	COIL		FSQH050RN
L9	COIL		FSQH050RN
L10	COIL		BT01RN1-A61
L11	COIL		BT01RN1-A61
L12	COIL		FSQH050RN
L13	COIL		BT01RN1-A61
L14	COIL		FSQH050RN
L15	COIL		BT01RN1-A61
L16	COIL		BT01RN1-A61
L17	COIL		FSQH050RN
L18	COIL		BT01RN1-A61
L19	COIL		LR-83
L20	COIL		LR-156
L21	COIL		LR-146

[PA] UNIT (POWER AMPLIFIER)

REF. NO.	DESCRIPTION	VALUE	PART NO.
L51	COIL	100k	LAL03NA
L52	COIL	2k	LAL04NA
C3	BARRIER	0.047	25V
C5	BARRIER	0.047	25V
C10	BARRIER	0.047	25V
C23	ELECTROLYTIC	47	25V
C28	BARRIER	0.047	25V
C29	ELECTROLYTIC	1000	16V MS16
C30	BARRIER	0.047	25V
C31	BARRIER	0.1	16V
C32	CERAMIC	220P	50V
C104	CERAMIC	100P	50V
C105	BARRIER	0.015	25V
C106	BARRIER	0.015	25V
C107	CERAMIC	470	16V
C108	CERAMIC	47P	50V
C109	CERAMIC	220	50V
J1	CONNECTOR		LLR-6
J2	CONNECTOR		TL25P-03-V1
P1	CONNECTOR		TMP-P01X-A1
P2	CONNECTOR		TMP-P01X-A1
P3	CONNECTOR		SMR-04V-B
P5	CONNECTOR		1490R-1
P7	CONNECTOR		TL25H-03-B1
R1	RESISTOR	330	ELR25
R2	RESISTOR	150	R25
R3	RESISTOR	220	ELR25
R5	RESISTOR	4.7	R50X
R7	RESISTOR	68	R50X
R8	TRIMMER	100	H0651A
R9	RESISTOR	47	R25
R10	RESISTOR	47	25
R11	RESISTOR	120	R50X
R12	RESISTOR	120	R50X
R13	RESISTOR	10	R50X
R14	RESISTOR		RSS1B3.3-J
R15	RESISTOR		RSS1B3.3-J
R16	RESISTOR		RSS1B3.3-J
R17	RESISTOR		RSS1B3.3-J
R18	RESISTOR	120	R50X
R19	TRIMMER	470	H0651A
R20	RESISTOR	10	R50X
R21	RESISTOR	10	R50X
R22	RESISTOR		RSS1B3.3-J
R23	RESISTOR		RSS1B3.3-J
R25	RESISTOR	4.7	R2J
R26	RESISTOR		SQ5L0.012-J
R27	RESISTOR	1K	ELR25
R29	RESISTOR	1K	R25
R30	RESISTOR	330	R25
R31	RESISTOR	470	R25
R32	RESISTOR	6.8k	ELR25
R33	RESISTOR	10k	ELR20
R34	RESISTOR	22k	ELR20
R35	RESISTOR	22k	R25
R44	RESISTOR	560	R20
C1	CERAMIC	0.0047	50V
C2	CERAMIC	0.0022	50V
C3	BARRIER	0.047	25V
C4	BARRIER	0.047	25V
C5	BARRIER	0.047	25V

[PA] UNIT (POWER AMPLIFIER)

REF. NO.	DESCRIPTION	VALUE	PART NO.
C6	BARRIER	0.047	25V
C7	MYLAR	0.0047	50V
C8	MYLAR	0.0047	50V
C9	CERAMIC	220P	50V
C10	BARRIER	0.047	25V
C11	CERAMIC	0.001	50V
C12	MONOLITHIC	0.0068	GR44 CH
C13	MONOLITHIC	0.0068	GR44 CH
C14	BARRIER	0.047	25V
C15	BARRIER	0.047	25V
C16	ELECTROLYTIC	47	10V
C17	MONOLITHIC	0.001	GR44 CH
C18	CERAMIC	390P	50V
C19	CERAMIC	220P	500V
C20	DIP MICA	680P	DM19C681J51CR
C21	MONOLITHIC	0.001	GR44 CH
C22	CERAMIC	220P	500V
C23	ELECTROLYTIC	47	25V
C25	ELECTROLYTIC	1000	16V MS16
C26	BARRIER	0.1	16V
C27	CERAMIC	220P	500V
C28	BARRIER	0.047	25V
C29	ELECTROLYTIC	1000	16V MS16
C30	BARRIER	0.047	25V
C31	BARRIER	0.1	16V
C32	CERAMIC	220P	50V
C33	ELECTROLYTIC	10	16V
C34	CERAMIC	0.0047	50V
C35	ELECTROLYTIC	220	16V
C36	ELECTROLYTIC	47	25V
C37	BARRIER	0.047	25V
C38	CERAMIC	0.0047	50V
C39	CERAMIC	0.0047	50V
C40	MONOLITHIC	0.001	GR44 CH
C94	CERAMIC	0.0047	50V
C95	CERAMIC	0.0047	50V

J1	CONNECTOR	LLR-6
J3	CONNECTOR	TMP-J01X-V2
J4	CONNECTOR	FM-MDR MI
J5	CONNECTOR	

P1	CONNECTOR	TMP-P01X-A1
P2	CONNECTOR	TMP-P01X-A1
P3	CONNECTOR	SMR-04V-B
P5	CONNECTOR	1490R-1
P7	CONNECTOR	TL25H-03-B1
F1	FUSE	3A
F2	HOLDER	S-N5051
F3	HOLDER	S-N5051
W1	JUMPER	74/98/040/X98/X98
W2	JUMPER	74/98/050/X98/X98
W3	JUMPER	74/98/040/X98/X98
W4	JUMPER	74/98/040/X98/X98
W5	JUMPER	JPW-02A
W6	JUMPER	JPW-02H
W11		23/09/040/C21/W03
W12		23/09/040/C21/W03

[PA] UNIT (POWER AMPLIFIER)

REF. NO.	DESCRIPTION	VALUE	PART NO.
W14			23/05/070/C21/W03
W15			22/08/230/C21/B01
W16	JUMPER		23/02/140/C21/C21
W17			22/09/230/C21/B01
W18			22/00/230/C21/B01
W19			13/02/270/W06/A08
W20			13/00/310/W06/A08
W21			11/02/050/W04/B03
W22			11/02/055/W04/B03
W23			11/00/055/W04/B03
W24			11/00/050/W04/B03
W31	JUMPER		72/98/010/X98/X98
W32	JUMPER		72/98/010/X98/X98
W33	JUMPER		72/98/010/W06/X98
W34	JUMPER		72/98/010/X98/X98
W35	JUMPER		72/98/010/X98/X98
W36	JUMPER		72/98/010/X98/X98
W37	JUMPER		72/98/010/X98/X98
W38	JUMPER		72/98/010/X98/X98
W39	JUMPER		72/98/010/X98/X98
W40	JUMPER		72/98/010/X98/X98
W41	JUMPER		72/98/010/X98/X98
W42	JUMPER		72/98/010/X98/X98
W43	JUMPER		IPS-1041-4
W44			13/02/125/W06/W06
W45			23/02/290/W02/C01
W46			23/00/290/W02/C01
W47			13/05/350/B03/A08
W48			13/12/350/B03/A08
W49			62/99/240/C31/W13D
W50			08 D
W51			62/99/130/C31/W13D
W52			08 D
W53	JUMPER		31/06/055/C21/C21
W79	JUMPER		22/02/230/W03/B01
W80	JUMPER		74/98/040/X98/X98
W81	JUMPER		74/98/040/X98/X98
W82	JUMPER		74/98/050/X98/X98

[PA] UNIT (FILTER)

REF. NO.	DESCRIPTION	VALUE	PART NO.
D7	DIODE		1K60
D8	DIODE		1K60
D9	DIODE		1N4002
D10	DIODE		1N4002
D11	DIODE		1N4002
D12	DIODE		1N4002
D13	DIODE		1N4002
D14	DIODE		1N4002
D15	DIODE		1N4002
L24	COIL		LR-136
L25	COIL		LR-137
L26	COIL		LR-138
L27	COIL		LR-139
L28	COIL		LR-141
L29	COIL		LR-141
L30	COIL		LR-53
L31	COIL		LR-54

[PA] UNIT (FILTER)

REF. NO.	DESCRIPTION	VALUE	PART NO.
L32	COIL		LR-157
L33	COIL		LR-158
L34	COIL		LA-196
L35	COIL		LA-197
L36	COIL		LR-163
L37	COIL	101K	LAL03NA
L38	COIL	101K	LAL03NA
L39	COIL	101K	LAL03NA
L40	COIL	101K	LAL03NA
L41	COIL	101K	LAL03NA
L42	COIL	101K	LAL03NA
L43	COIL	100K	LAL03NA
L44	COIL	100K	LAL03NA
L45	COIL	100K	LAL03NA
L46	COIL	100K	LAL03NA
L47	COIL	100K	LAL03NA
L48	COIL	100K	LAL03NA
L49	COIL	101K	LAL03NA
L50	COIL		LR-151
R36	RESISTOR	10K	ELR25
R37	RESISTOR	10K	ELR25
R38	RESISTOR	47K	ELR25
R39	RESISTOR	68	R50X
R40	RESISTOR	10K	ELR25
R41	RESISTOR	10K	ELR25
R42	RESISTOR	47K	ELR25
R43	ABSORBER		DSA301LA
R45	RESISTOR	33K	ELR25
C43	DIP MICA	0.0015	DM20C152J51CR
C44	DIP MICA	470P	DM19C471J51CR
C45	DIP MICA	0.0027	DM20C272J51CR
C46	CERAMIC	500V	120P
C47	DIP MICA	0.0015	DM20C152J51CR
C48	DIP MICA	560P	DM19C561J51CR
C49	CERAMIC	500V	220P
C50	DIP MICA	0.0012	DM20C122J51CR
C51	CERAMIC	500V	68P
C52	DIP MICA	680P	DM19C681J51CR
C53	CERAMIC	500V	220P
C54	CERAMIC	500V	100P
C55	DIP MICA	680P	DM19C681J51CR
C56	CERAMIC	500V	33P
C57	CERAMIC	500V	220P
C58	CERAMIC	500V	150P
C59	CERAMIC	500V	27P
C60	CERAMIC	500V	330P
C61	CERAMIC	500V	82P
C62	CERAMIC	500V	180P
C63	CERAMIC	500V	120P
C64	CERAMIC	500V	12P
C65	CERAMIC	500V	220P
C66	CERAMIC	33P	500V
C67	CERAMIC	100P	500V
C68	CERAMIC	68P	500V
C69	CERAMIC	39P	500V
C70	CERAMIC	68P	500V
C71	CERAMIC	12P	500V
C72	CERAMIC	82P	500V
C73	CERAMIC	330P	50V
C74	TRIMMER	CTZ51E	20P

[PA] UNIT (FILTER)

REF. NO.	DESCRIPTION	VALUE	PART NO.
C75	CERAMIC	0.0047	50V
C76	CERAMIC	0.0047	50V
C77	BARRIER	0.047	25V
C78	BARRIER	0.047	25V
C79	BARRIER	0.047	25V
C80	BARRIER	0.047	25V
C81	BARRIER	0.047	25V
C82	BARRIER	0.047	25V
C83	CERAMIC	0.0047	50V
C84	CERAMIC	0.0047	50V
C85	CERAMIC	0.0047	50V
C86	CERAMIC	0.0047	50V
C87	CERAMIC	0.0047	50V
C88	CERAMIC	0.0047	50V
C89	BARRIER	0.047	25V
C90	CERAMIC	120P	50V
C91	CERAMIC	20P	50V
C92	CERAMIC	120P	50V
C93	CERAMIC	330P	50V
C96	CERAMIC	82P	500V
C97	CERAMIC	180P	500V
C98	CERAMIC	180P	500V
RL1	RELAY		MZ12HG
RL2	RELAY		MZ12HG
RL3	RELAY		MZ12HG
RL4	RELAY		MZ12HG
RL5	RELAY		MZ12HG
RL6	RELAY		MZ12HG
RL7	RELAY		MZ12HG
RL8	RELAY		MZ12HG
RL9	RELAY		MZ12HG
RL10	RELAY		MZ12HG
RL11	RELAY		MZ12HG
RL12	RELAY		MZ12HG
RL13	RELAY		NR-HD-6V
J3	CONNECTOR		TMP-J01X-V2
P4	CONNECTOR		SMR-03V-B
P6	CONNECTOR		TL25H-07-B1
W54	JUMPER		JPW-02A
W55	JUMPER		74/98/030/X98/X98
W56	JUMPER		74/98/040/X98/X98
W57	JUMPER		74/98/040/X98/X98
W58	JUMPER		IPS-1041-4
W59	JUMPER		IPS-1041-4
W60	JUMPER		JPW-02A
W61	JUMPER		JPW-02A
W62			23/01/210/C21/C01
W63			23/02/195/C21/C01
W64			23/03/205/C21/C01
W65			23/04/260/C21/C01
W66			23/05/250/C21/C01
W67			23/06/220/C21/C01
W68	JUMPER		23/01/095/C21/C21
W69	JUMPER		23/02/110/C21/C21
W70	JUMPER		23/03/110/C21/C21
W71	JUMPER		23/04/075/C21/C21
W72	JUMPER		23/05/075/C21/C21
W73	JUMPER		23/06/140/C21/C21

[PA] UNIT (FILTER)

REF. NO.	DESCRIPTION	VALUE	PART NO.
W74			22/07/265/C21/B01
W75			22/08/265/C21/B01
W76			22/09/270/C21/B01
W78			80/99/020/X98/X98

[SENSOR] UNIT

Q1	PHOTO		IS-433
Q2	PHOTO		IS-433
R1	RESISTOR	220	R20
C1	BARRIER		UATO6V 103K 50V 0.01
P1	CONNECTOR		TL25H-04-B1
DS1	LED		GL-430
DS2	LED		GL-430
EP1	PC BOARD		B-1016A

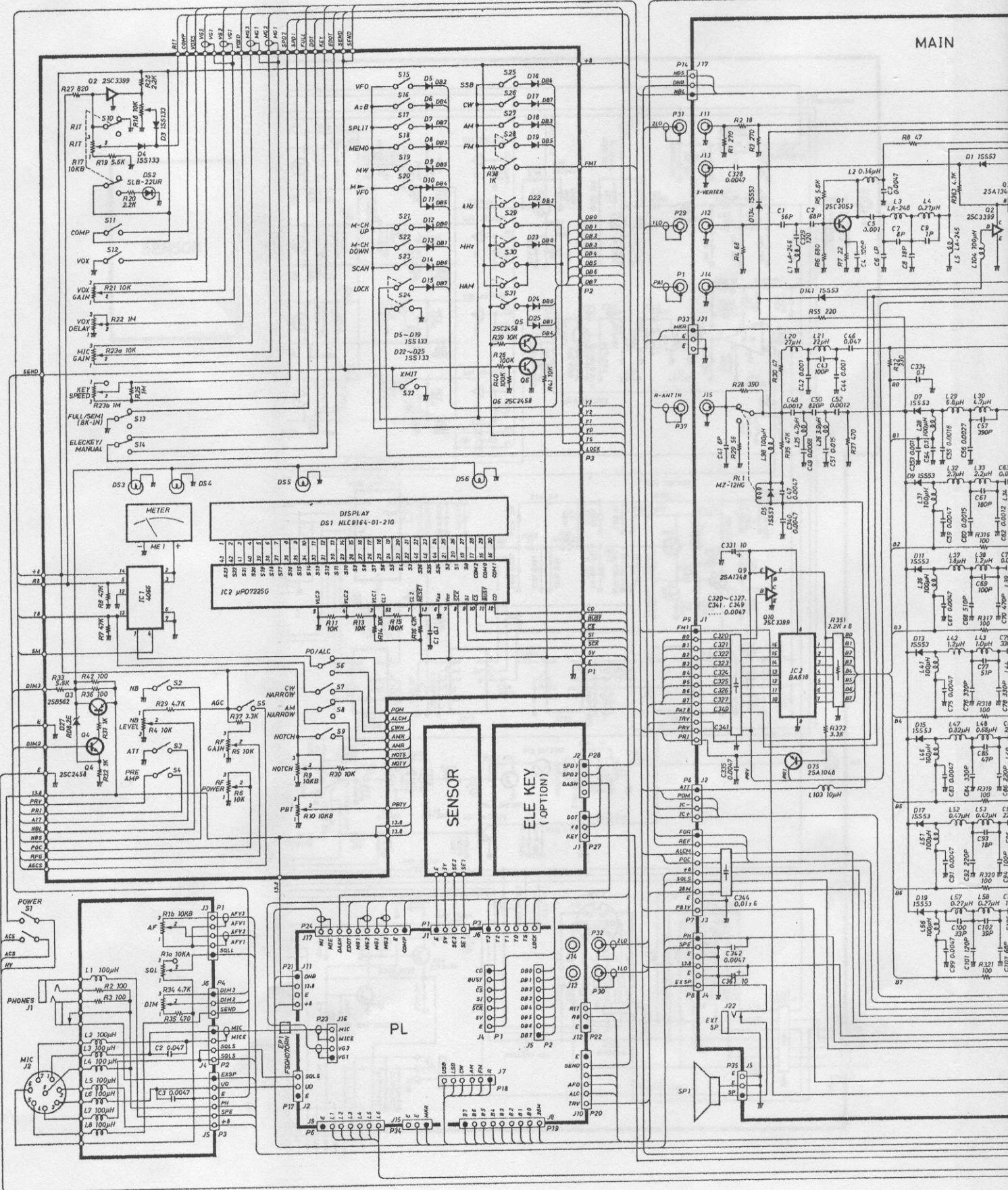

MAIN

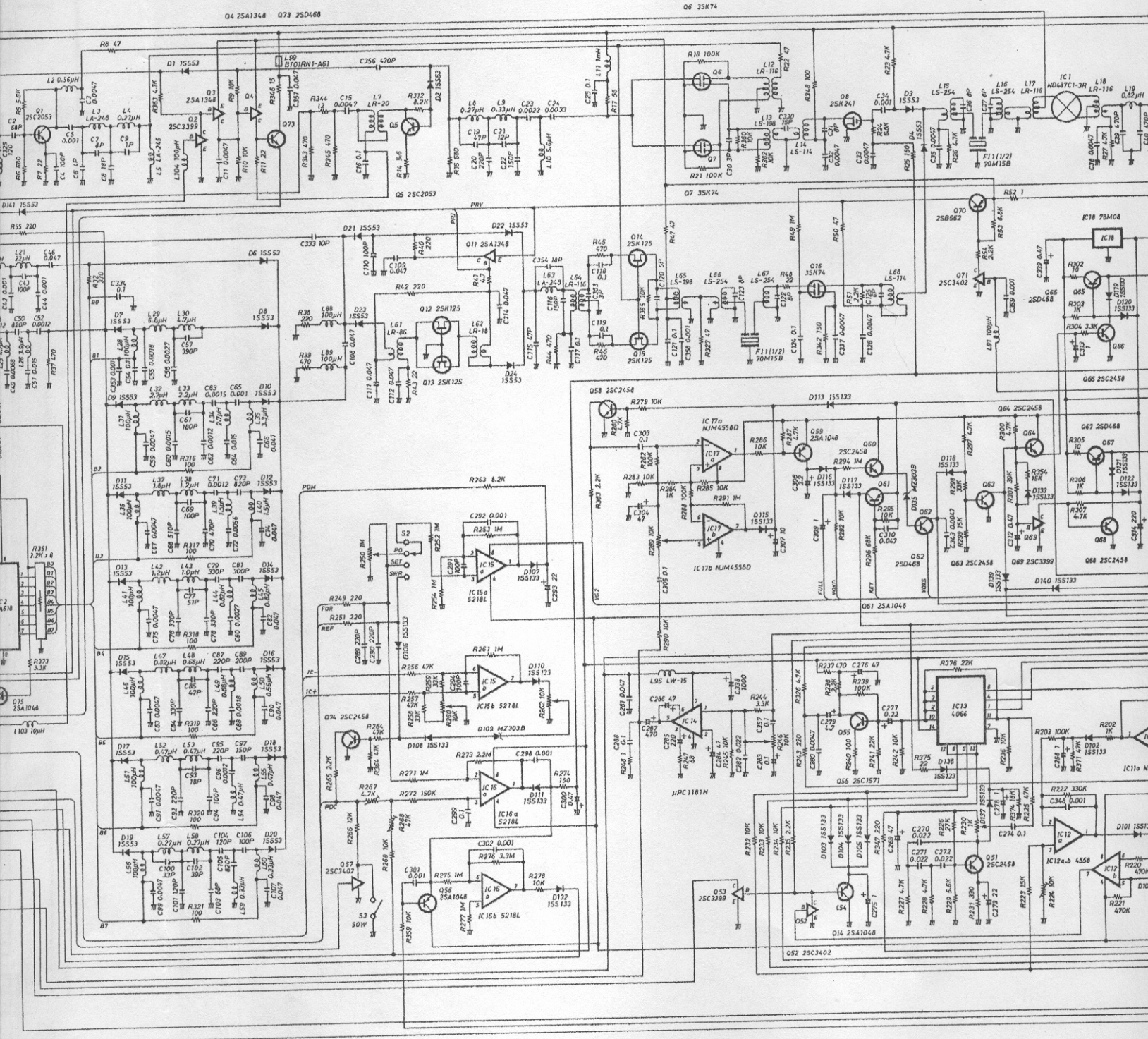

(PL~MAIN) FRONT~
 (FRONT~MAIN) ELE KEY
 (PL~PA) FRONT~

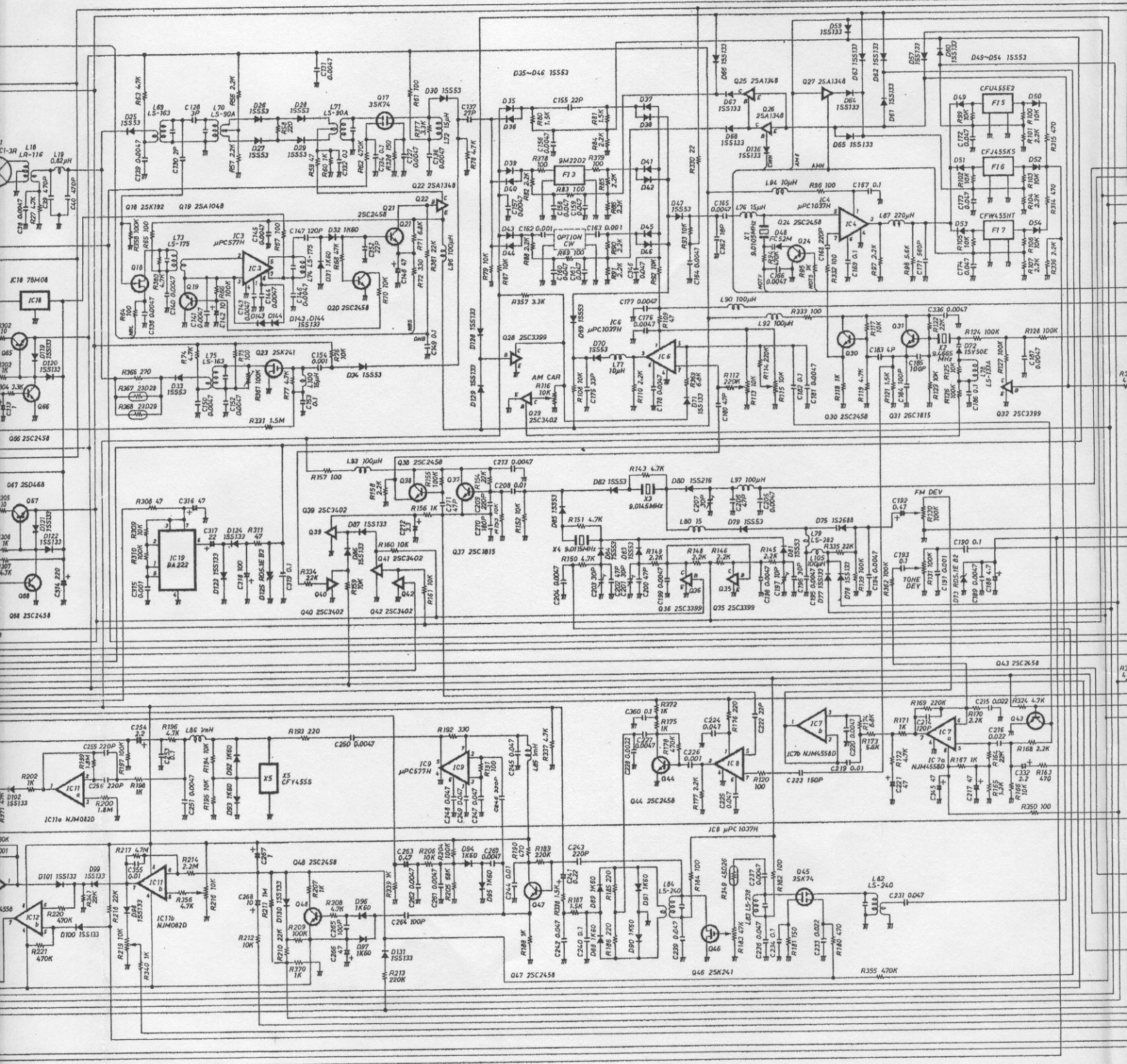

(MAIN) (FRONT-MAIN)
(MAIN) (ELE KEY-MAIN)
(PA) (FRONT-PA)

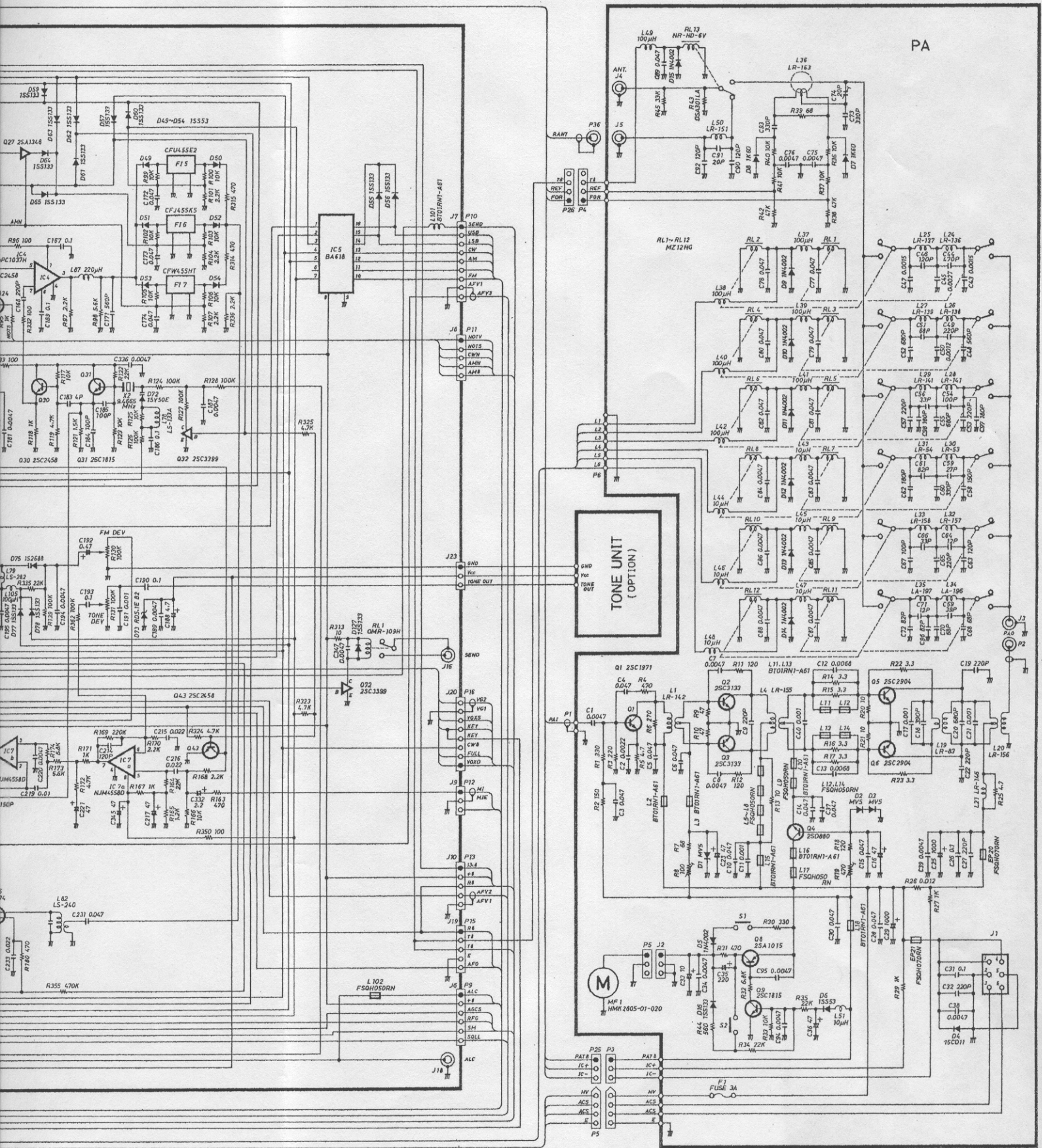

To upgrade quality, some components may be subject to change without notice.

A-0650-N

Icom Inc.

